

SpectraLight QC



Operation Manual

Register your product and get access to important product updates, exclusive content, service support, and other tools to help you get the most of your product.
www.xrite.com/registration

Macbeth Lighting



Consult this documentation in all cases where the Attention symbol  appears. This symbol is used to inform you of any potential HAZARD or actions that may require your attention.

CE Declaration



Hereby, X-Rite, Incorporated, declares that this Spectralight QC is in compliance with the essential requirements and other relevant provisions of Directive(s) 2014/30/EU (EMC), 2014/35/EU (LVD), and RoHS EU 2015/863.

The optional remote control for this unit additionally complies with RED 2014/53/EU.

Federal Communications Commission Notice

NOTE: This equipment has been tested and found to comply with the limits for a Class A digital device, pursuant to Part 15 of the FCC Rules. These limits are designed to provide reasonable protection against harmful interference when the equipment is operated in a commercial environment. This equipment generates, uses, and can radiate radio frequency energy and, if not installed and used in accordance with the instruction manual, may cause harmful interference to radio communications. Operation of this equipment in a residential area is likely to cause harmful interference in which case the user will be required to correct the interference at his own expense.

Industry Canada Compliance Statement

This Class A digital apparatus complies with Canadian ICES-003.

Cet appareil numérique de la classe A est conforme à la norme NMB-003 du Canada.

Equipment Information



IF THE EQUIPMENT IS USED IN A MANNER NOT SPECIFIED BY X-RITE, THE PROTECTION PROVIDED BY THE EQUIPMENT MAY BE IMPAIRED.

CAUTION! DO NOT connect to an ungrounded outlet. DO NOT use with 2-wire extension cords or adaptors

WARNING: This instrument is not for use in explosive environments.



Instructions for disposal: Please dispose of Waste Electrical and Electronic Equipment (WEEE) at designated collection points for the recycling of such equipment.

Safety Information



PLEASE READ AND FOLLOW INSTRUCTIONS: Read and follow all instructions before you attempt to assemble, install or operate the unit.

- **RETAIN THIS MANUAL FOR FUTURE REFERENCE:** Once you have read this manual, keep it handy for others to read or refer to when they need to operate the unit.
- **OBEY WARNINGS:** Please comply with all warnings and safeguards that we provide in this manual. They have been written to keep you and your unit safe. If the unit is used in a manner not specified in this manual, the protection provided by the unit may be impaired.
- **USE ONLY A PROPER POWER SOURCE:** Use the proper power source for this unit. Consult the power label on the back of the unit for this information. Operation with a power source not specified on the power label may result in inaccurate lighting conditions, damage to the equipment, and possible personal injury.
- **DO NOT BLOCK VENTS:** The luminaire(s) should be installed so that it is a minimum of 200 mm (8 in.) from each other or wall surface. Light sources contribute heat to the area of operation. SpectraLight QC thermal contribution is 3900 BTU maximum per hour that is dissipated through the vents on the short sides and in the top panel. Blocking of the vent could result in overheating,

mechanical failure, and a fire hazard if flammables or combustibles are present. Never place any objects on top of the luminaire.

- **PROTECT FROM WATER AND MOISTURE:** Do not install overhead luminaires under a sprinkler system. Maintain electrical safety when you use this unit. Do not use it in an area where there is possible hazard of electric shock from spilled water or other liquids or uncontrolled moisture.
- **CLEAN PROPERLY:** You can wipe the unit with a clean, white lint-free cloth. Do not apply liquid cleaners or agents containing wax, since these can yellow and change reflectance and gloss properties. Clean outer surfaces with a dampened cloth containing a mild soap.
- **CAREFULLY HANDLE THE LAMPS AND DAYLIGHT FILTERS:** Allow the lamps and daylight filters to cool before handling them. Always use lens paper or an equivalent to handle any of the replacement tungsten halogen lamps. Skin oils interfere with lamp performance.
- **EMERGENCY SHUT-OFF:** The unit should be installed near a main power shut-off switch in the event of an emergency.
- **KEEP LUMINAIRE PACKAGING:** In the event of a scenario requiring return of the luminaire for service or replacement, please save the luminaire packaging in a dry location for future use.



Glass diffuser, filters, and lamps get hot during operation. Allow time to cool before touching.

Proprietary Notice

The information contained in this manual is copyrighted information proprietary to X-Rite, Incorporated.

Publication of this information does not imply any rights to reproduce or use it for purposes other than installing, operating, or maintaining this instrument described herein. No part of this manual may be reproduced, transcribed or translated into any language or computer language in any form or by any means: electronic, magnetic, mechanical, optical, manual, or otherwise; without the prior written permission of an authorized officer of X-Rite, Incorporated.

Patents: www.xrite.com/ip

“© 2023, X-Rite, Incorporated. All rights reserved”

X-Rite® and SpectraLight® are registered trademarks of X-Rite, Incorporated. All other logos, brand names, and product names mentioned are the properties of their respective holders.

Warranty Information

X-Rite warrants this Product against defects in material and workmanship for a period of twelve (12) months from the date of shipment from X-Rite's facility, unless mandatory law provides for longer periods. During such time, X-Rite will either replace or repair at its discretion defective parts free of charge.

X-Rite's warranties herein do not cover failure of warranted goods resulting from: (i) damage after shipment, accident, abuse, misuse, neglect, alteration or any other use not in accordance with X-Rite's recommendations, accompanying documentation, published specifications, and standard industry practice; (ii) using the device in an operating environment outside the recommended specifications or failure to follow the maintenance procedures in X-Rite's accompanying documentation or published specifications; (iii) repair or service by anyone other than X-Rite or its authorized representatives; (iv) the failure of the warranted goods caused by use of any parts or consumables not manufactured, distributed, or approved by X-Rite; (v) any attachments or modifications to the warranted goods that are not manufactured, distributed or approved by X-Rite. Consumable parts and Product cleaning are also not covered by the warranty.

X-Rite's sole and exclusive obligation for breach of the above warranties shall be the repair or replacement of any part, without charge, which within the warranty period is proven to X-Rite's reasonable satisfaction to have been defective. Repairs or replacement by X-Rite shall not revive an otherwise expired warranty, nor shall the same extend the duration of a warranty.

Customer shall be responsible for packaging and shipping the defective product to the service center designated by X-Rite. X-Rite shall pay for the return of the product to Customer if the shipment is to a location within the region in which the X-Rite service center is located. Customer shall be responsible for paying all shipping charges, duties, taxes, and any other charges for products returned to any other locations. Proof of purchase in the form of a bill of sale or receipted invoice which is evidence that the unit is within the Warranty period must be presented to obtain warranty service. Do not try to dismantle the Product. Unauthorized dismantling of the equipment will void all warranty claims. Contact the X-Rite Support or the nearest X-Rite Service Center, if you believe that the unit does not work anymore or does not work correctly.

THESE WARRANTIES ARE GIVEN SOLELY TO BUYER AND ARE IN LIEU OF ALL OTHER WARRANTIES, EXPRESSED OR IMPLIED, INCLUDING BUT NOT LIMITED TO THE IMPLIED WARRANTIES OF MERCHANTABILITY, FITNESS FOR A PARTICULAR PURPOSE OR APPLICATION, AND NON-INFRINGEMENT. NO EMPLOYEE OR AGENT OF X-RITE, OTHER THAN AN OFFICER OF X-RITE, IS AUTHORIZED TO MAKE ANY WARRANTY IN ADDITION TO THE FOREGOING.

IN NO EVENT WILL X-RITE BE LIABLE FOR ANY OF BUYER'S MANUFACTURING COSTS, OVERHEAD, LOST PROFITS, GOODWILL, OTHER EXPENSES OR ANY INDIRECT, SPECIAL, INCIDENTAL OR CONSEQUENTIAL DAMAGES BASED UPON BREACH OF ANY WARRANTY, BREACH OF CONTRACT, NEGLIGENCE, STRICT TORT, OR ANY OTHER LEGAL THEORY. IN ANY EVENT OF LIABILITY, X-RITE'S MAXIMUM LIABILITY HEREUNDER WILL NOT EXCEED THE PRICE OF THE GOODS OR SERVICES FURNISHED BY X-RITE GIVING RISE TO THE CLAIM.

Table of Contents

Introduction and Installation	5
Key Features	5
Unpacking	5
Recommendations for Placement	6
Viewing Booth Assembly	6
Installing Luminaire Into Light Booth	9
Overhead Luminaire Installation	11
Powering Up	13
Navigating the Screen	13
SpectraLight QC Software Utility	14
System Requirements	14
Software Installation	14
System Setup (ADMIN)	15
Owner Profile Setup (OWNER)	15
Primary System Settings (SYS)	16
Reset Lamp Hour Counter and Lifetime (RLAMP)	18
Create Operator Profiles (PROFL)	20
Moving Lamp Switch Order and Auto-Sequencing the Light Sources (SEL)	22
Edit Operator Profiles (OPER)	23
Date and Time Setup (TIME)	24
User Settings (USER)	25
Display System Information (INFO)	26
Daisy Chain Configuration Setup (CHAIN)	27
Operation	29
Selecting a Lamp Source	29
Auto Sequence	30
Display Adjustment	31
Sensor Display (for service only)	32
System Operating Language	32
Running System Reports	32
Remote Control Operation	35
Operation	35
Remote Address Code Table	35
Optional Control Box	36
Installation	36
Appendices	37
Service Information	37
Luminaire Repackaging	37
General Maintenance	37
Cleaning (visible dust and dirt significantly reduce light output)	37
Replacing the Lamps	40
Replacing the Fuse	41
Screen Messages	41
Troubleshooting	42
Specifications	43
Menu Screen Flowchart	44
Parts and Accessories	48

INTRODUCTION AND INSTALLATION

The X-Rite SpectraLight QC (SPLQC) is a visual color evaluation system which provides selectable light sources.

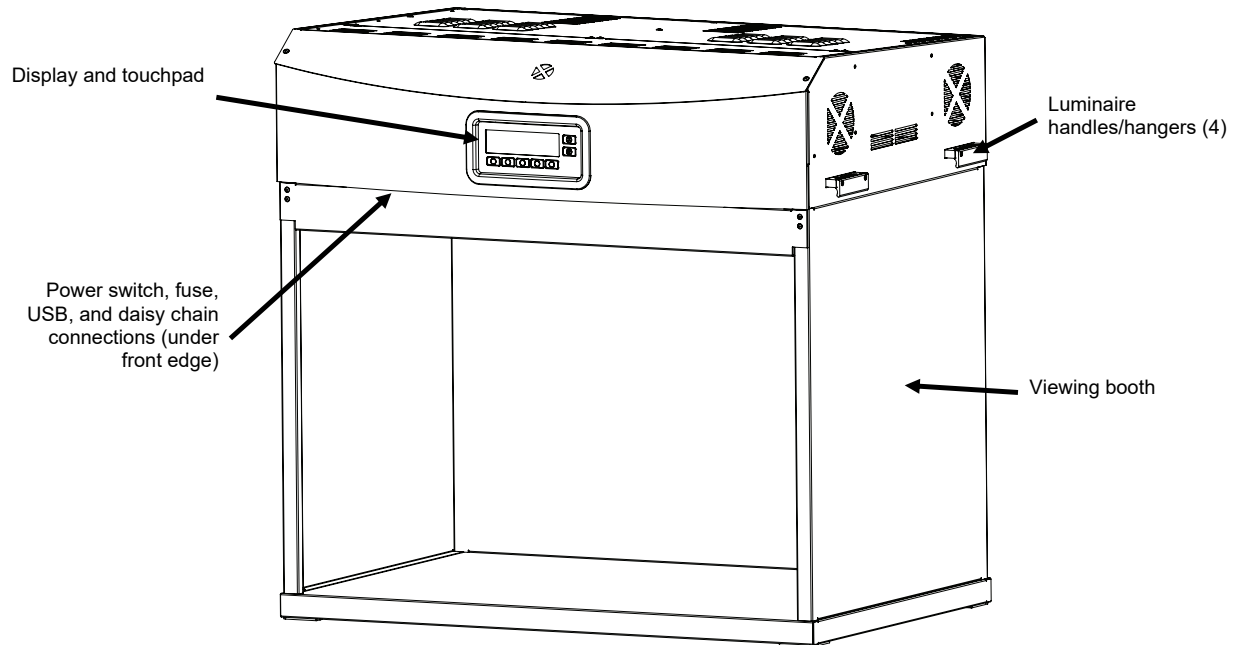

Key Features

Seven light sources:

- DL (daylight): filtered tungsten halogen calibrated CCT 5000K or 6500K
- HZ: calibrated tungsten halogen CCT 2300K
- A (Incandescent A): calibrated tungsten halogen CCT 2856K
- FL1 (fluorescent): adjustable light levels
- FL1 LED 4000K or 5000K
- FL2 (fluorescent): adjustable light levels
- FL3 (fluorescent): adjustable light levels
- UV: calibrated and adjustable UVA levels

Other features:

- Intelligent lamp power supply unit (PSU)
- Dimmable electronic ballasts (0-10V)
- Three configurable fluorescent light sources
- Built-in light sensors to monitor light levels
- Adjustable light levels and automatic lux control
- Handles for easy setup and hanging luminaires
- Easy handle diffuser with safety switch
- Easy to replace daylight lux attenuators (snap in mechanism; optional accessory)
- Built-in real time clock
- Computer interface for control and monitoring
- Versatile user interface configurations in English or Chinese

Unpacking

Your system packaging should contain all the items listed below. If any of these items are missing or damaged, contact X-Rite or your Authorized Representative.

- SpectraLight QC luminaire
- USB interface cable
- AC line cord
- Remote control (optional)
- Daisy chain cable (optional)
- Viewing booth assembly (optional)
- Manuals & utilities CD
- Other documentation

Recommendations for Placement

X-Rite SpectraLight QC is designed for critical color evaluation. Therefore, it is important that precautions be taken to ensure the best environment for this purpose.

- Viewing booth installations provide an area which is manufactured in conformance with ASTM standards. The work surface and surround area of view are neutral in color and low in gloss. The opening of the booth should face an area that provides the least interference from ambient light (natural or artificial).
- Overhead luminaire installations require the user to develop a controlled viewing environment. Contamination from other light sources can minimize the effectiveness of a standardized source, so the evaluation area should always be shielded from ambient light (natural or artificial). The best location for an overhead luminaire is in a windowless room with no interference from other light sources. If these conditions are not available, a viewing booth should be constructed. To avoid color misjudgments, the background on which the sample is placed and the surrounding area of view should be neutral in color and have a low gloss.
- Do not block vents – luminaire(s) should be installed so that it is a minimum of 200 mm (8 inches) from the next luminaire or a wall surface. It is recommend that luminaires are positioned no less than 60cm (2 feet) from the nearest walls to limit the impact of reflected light on light level uniformity.
- Luminaire Angle: Only position suspended overhead luminaires at an angle with the axis of rotation parallel to the longest side. In other words, the long axis should be parallel to the floor. Do not rotate luminaires in excess of 90 degrees from the downward position.



Viewing Booth Assembly

Move the viewing booth shipping container to the general area that the booth is to be used. Be sure to allow for sufficient room for assembly.

Carefully examine shipping containers for contents before discarding.

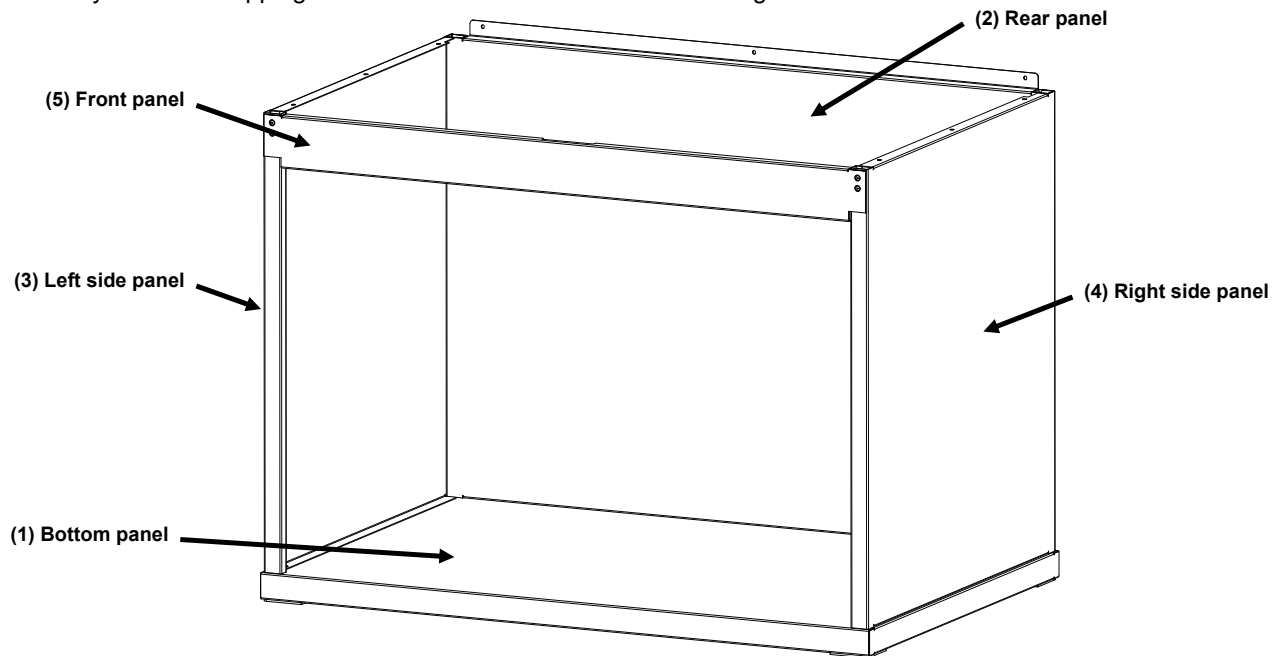

Assembled booth



CAUTION: Avoid scratching the surface of any of the items in the following assembly steps.

1. Place the bottom panel (1) on a clean, smooth surface. Refer to Figure 1.

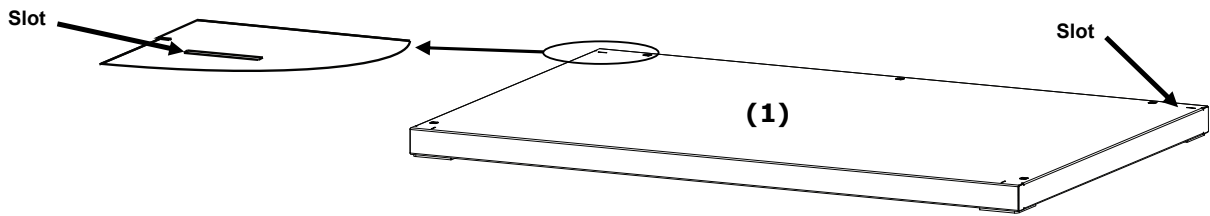

Figure 1. Bottom panel

2. Position the rear panel (2) bottom tabs into the bottom panel (1) rear slots. Fasten the rear panel to the bottom panel by securing it with three screws as shown in Figure 2.

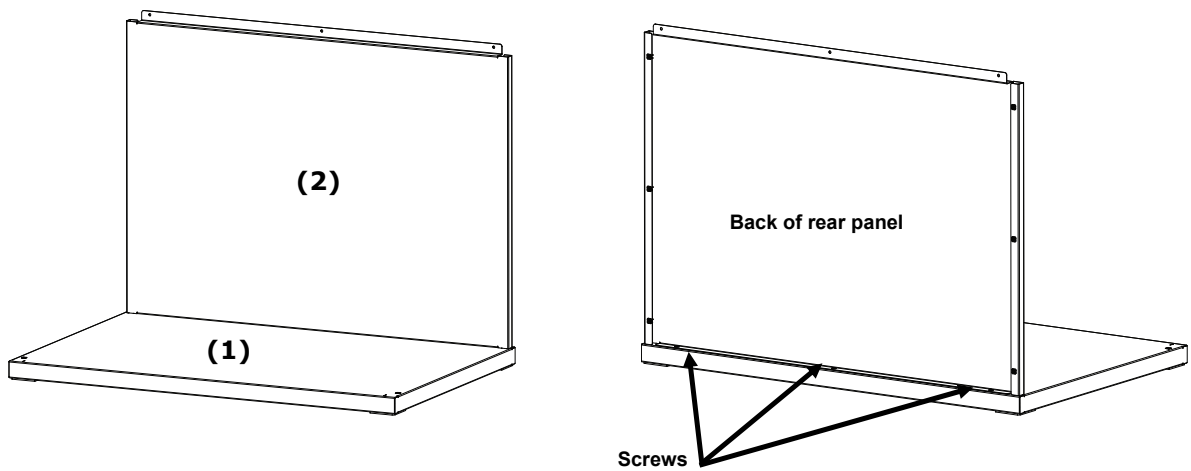

Figure 2. Rear into bottom panel

3. While supporting the rear panel (2), position the left panel (3) with the smooth side out over the top edge of the rear panel (2).
4. Slide the left panel (3) downward along the interlocking channel until the left panel (3) front tab inserts into the bottom panel (1). Fasten the left panel (3) to the bottom panel and rear panel by securing it with four screws as shown in Figure 3.

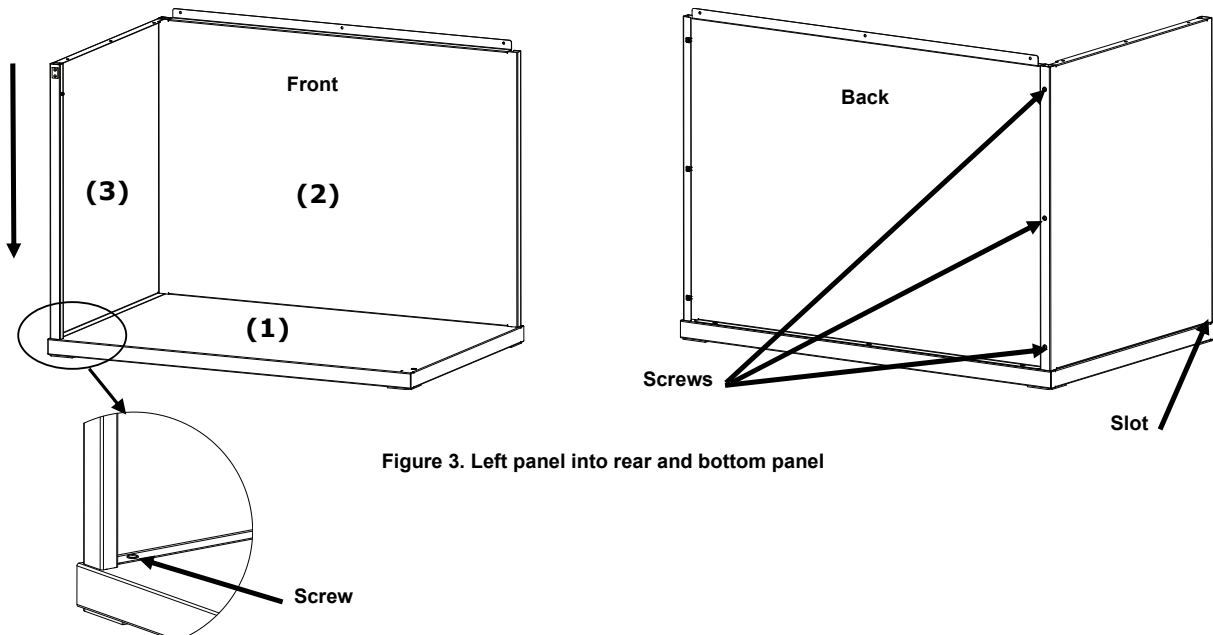

Figure 3. Left panel into rear and bottom panel

5. Position the right panel (4) with the smooth side out over the top edge of the rear panel (2).
6. Slide the right panel (4) downward along the interlocking channel until the right panel (4) front tab inserts into the bottom panel (1). Fasten the right panel (4) to the bottom panel and rear panel by securing it with four screws as shown in Figure 4.

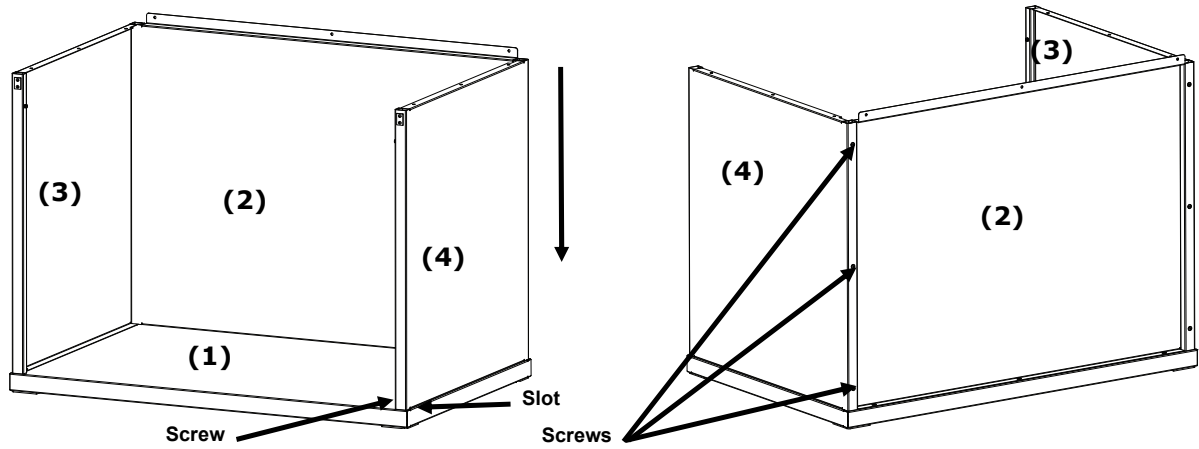

Figure 4. Right panel into rear and bottom Panel

7. Slide the pivot slots on the front panel (5) onto the pivots located on each of the two side panels.
8. Rotate the front panel upwards toward the unit until the magnets come into contact with the front panel. See Figure 5.

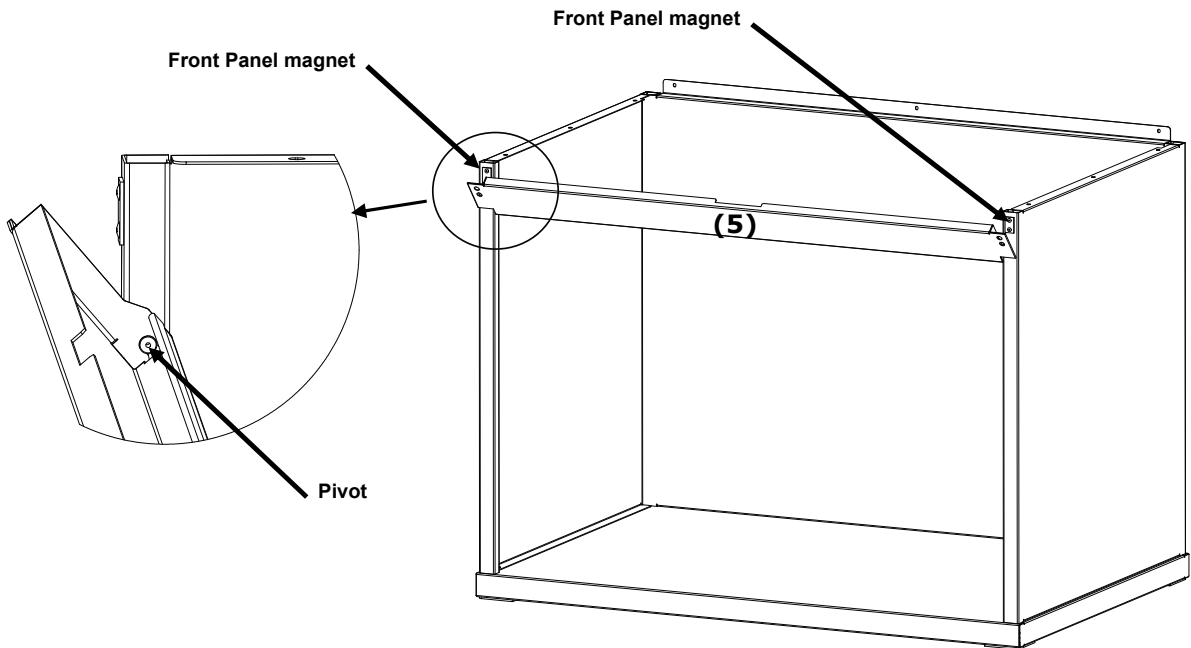

Figure 5. Front panel assembly

Installing Luminaire Into Light Booth

NOTE: The table or bench height should be determined by the average height of the observer and whether observations will be made from a standing or sitting position.

1. Position the assembled viewing booth on the surface where it will be used.
2. Carefully unpack and remove the diffuser from the shipping carton and set aside. Make sure to keep the shipping container and packing in the event that reshipment becomes necessary.



ATTENTION: Due to the weight of the luminaire, two people are required to perform the following steps.

3. Carefully unpack and remove the overhead luminaire from its shipping container using the handles/brackets located on the short sides.

NOTE: Be sure to remove all packing foam from inside the luminaire.

4. With its controls and indicators facing to the front, carefully place the luminaire on top of the viewing booth. Align the luminaire on the viewing booth.
5. Secure the luminaire to the rear, left and right panels of the booth using nine screws.

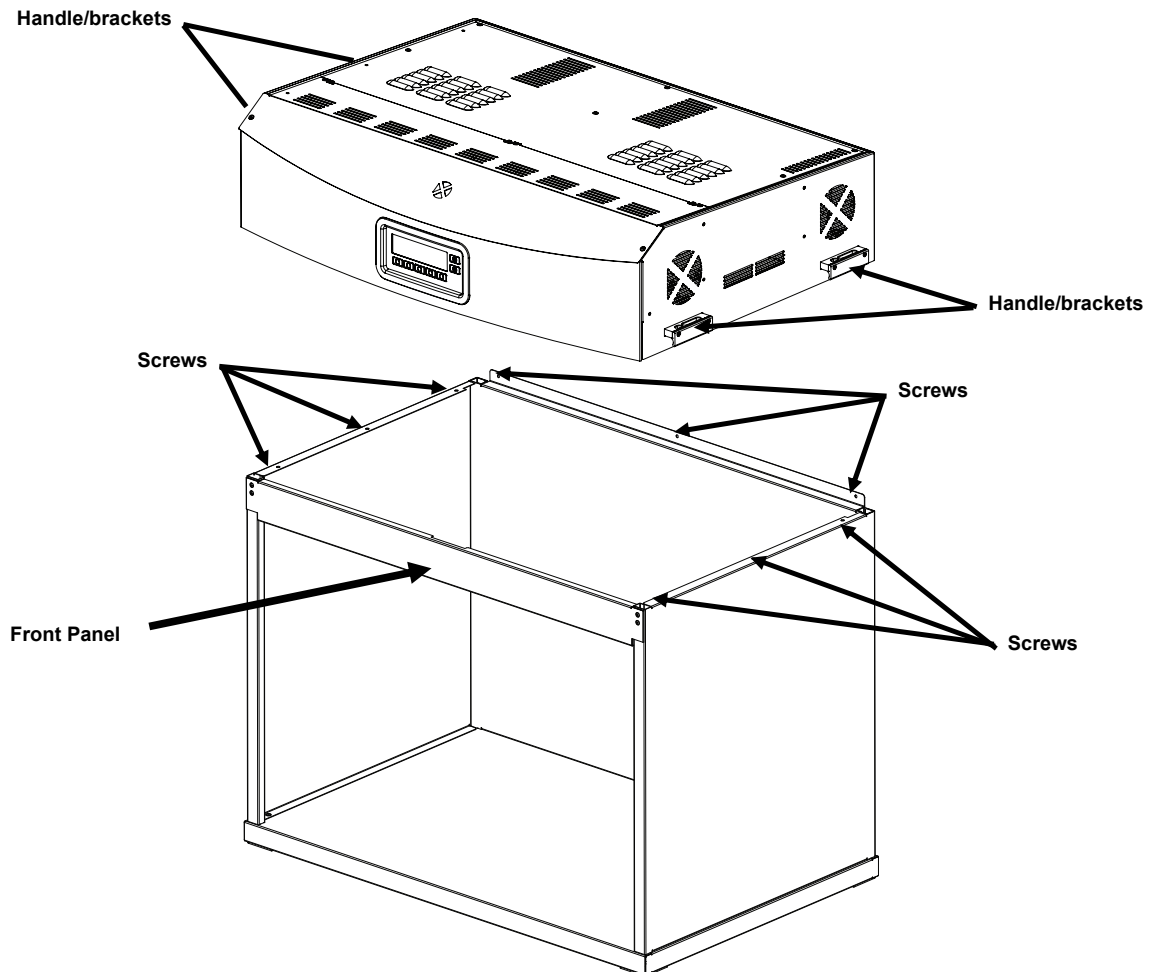

Figure 6. Luminaire Placement

6. Place assembled viewing booth and luminaire in or near the center of a table or bench capable of holding a minimum of 136 kg (300 lbs).
7. Remove the front panel from the light booth for diffuser installation.



CAUTION: Be careful not to scratch the interior of the booth. Make sure the hinge pins on the diffuser are carefully placed behind the back fluorescent lamp to avoid lamp breakage.

8. Hold the diffuser with the smooth side facing up toward the luminaire.
9. Insert the diffuser hinge pins at each back corner into the front slot of the receptacles located at the rear corners of the luminaire housing. Refer to Figure 7.

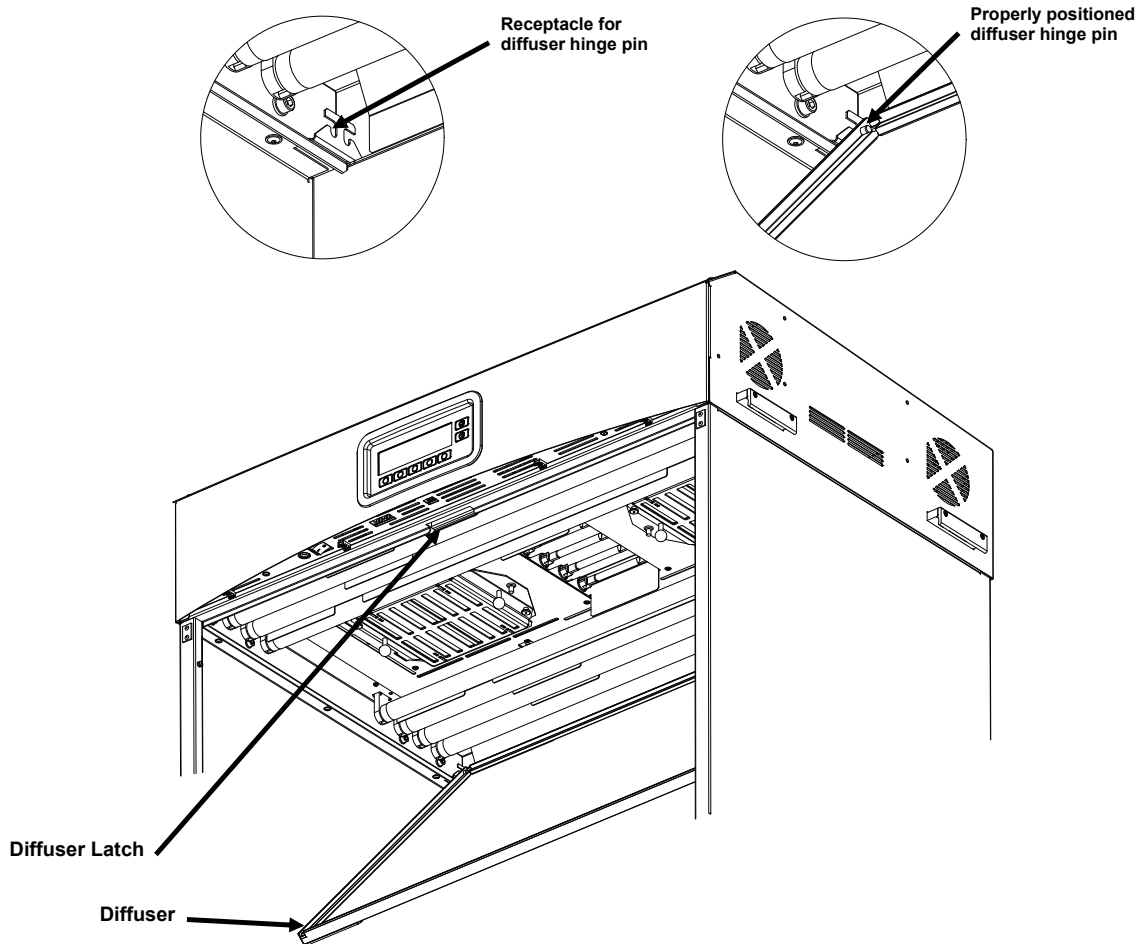

Figure 7. Luminaire Showing Diffuser

10. Rotate the diffuser to its closed position and secure it in place with the latch.



CAUTION: Ensure that the diffuser latch is secured before releasing. Failure to do so may result in the diffuser sliding out of position.

11. Reinstall the front panel.



CAUTION: Before plugging in the unit, verify the voltage indicated on the SpectraLight QC back label complies with the AC line voltage in your area. If not, contact X-Rite or an authorized representative.

12. Plug the SpectraLight QC into an AC wall outlet.
13. Refer to the Operation section for information on powering up and usage.

NOTE: If the diffuser is opened during operation, power to the lamps is disabled.

Overhead Luminaire Installation

The following describes a single and multiple overhead luminaire installation.

NOTE: Luminaires do not ship with attenuators. It is recommended attenuators are removed from overhead luminaires to maximize daylight illuminance.



CAUTION: Do not install the overhead luminaire under a fire sprinkler system. Dissipated heat from the luminaire may cause the sprinkler system to activate.



Install according to local electrical regulations. A dedicated branch circuit is recommended for each luminaire. Daylight maximum operating wattage of 1150W.

1. Carefully unpack and remove the diffuser from the shipping carton and set aside.



ATTENTION: Due to the weight of the luminaire, two people are required to perform the following steps.

2. Carefully unpack and remove the overhead luminaire from its shipping container using the handles/brackets located on the short sides.



CAUTION: Ensure adequate support in the next step. Each unit weighs 40.5 kg (89.3 lbs). Chains must be rated for 81.6 kg (180 lbs) each.

3. Attach karabiners and chains (not included) to each of the brackets and suspend the unit(s) at the appropriate height and angle over the work area. Luminaires should be installed so that it is a minimum of 200 mm (8 in.) from each other or wall surface. Refer to Figure 8.

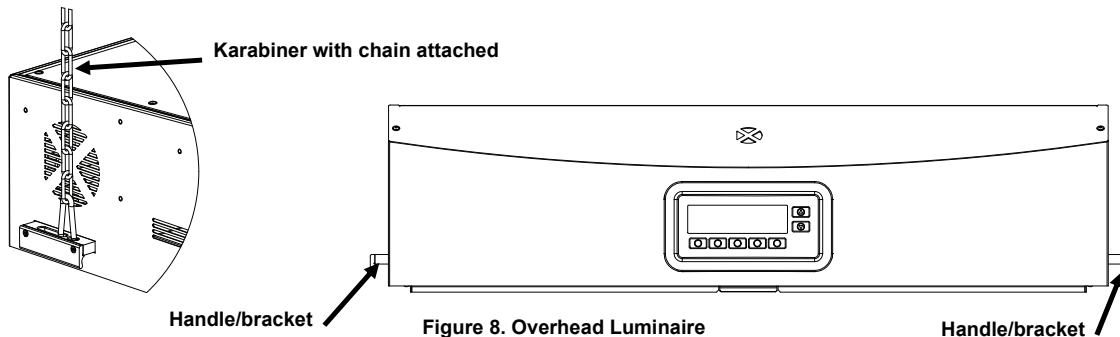

4. Carefully unpack and remove the diffuser from its carton.



CAUTION: In the following step, make sure the hinge pins are carefully placed behind the back fluorescent lamp to avoid lamp breakage.

5. Hold the diffuser with the smooth side facing up toward the luminaire.
6. Insert the diffuser hinge pins at each back corner into the front slot of the receptacles located at the rear corners of the luminaire housing. Refer to figure 9.

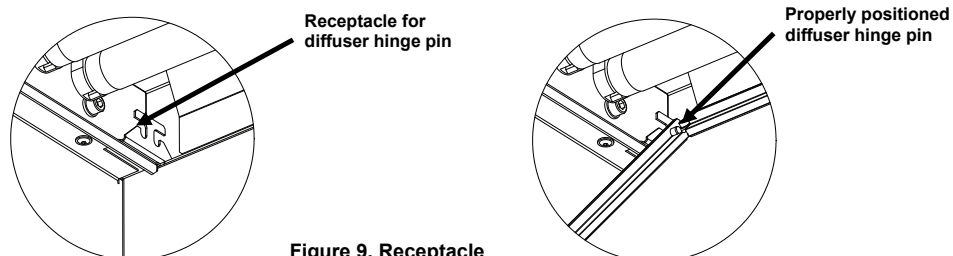

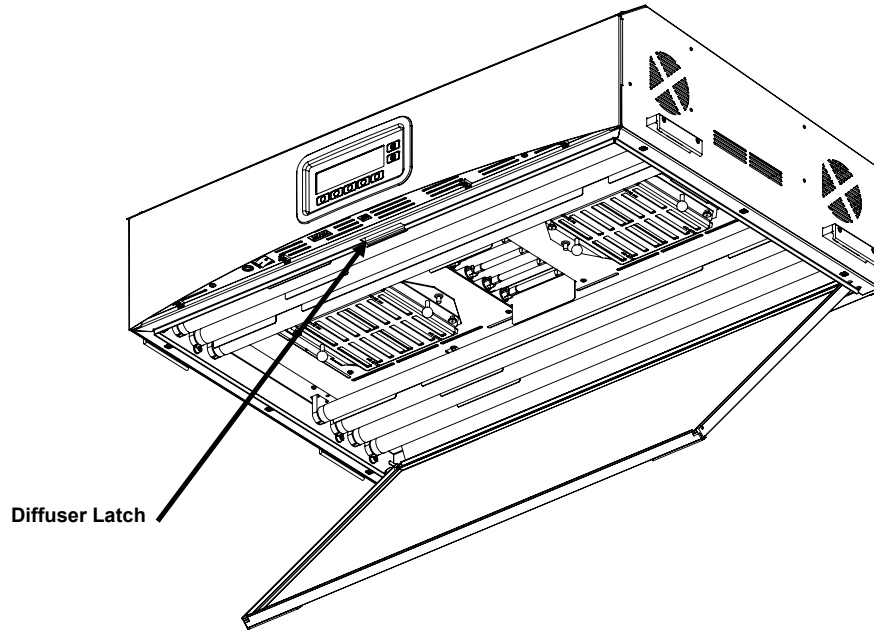

Figure 10. Luminaire Showing Diffuser Mounting

7. Rotate the front of the diffuser to its closed position and secure it in place with the latch. Refer to Figure 10.
8. For a single luminaire installation, advance to step 10. For multiple luminaire installations, repeat steps 4 through 7 and then continue with step 9.
9. Connect the luminaire with daisy chain cables between the luminaires at the front near the diffuser latch. Use the cable clips to hold the cables in place. Refer to Figure 11.

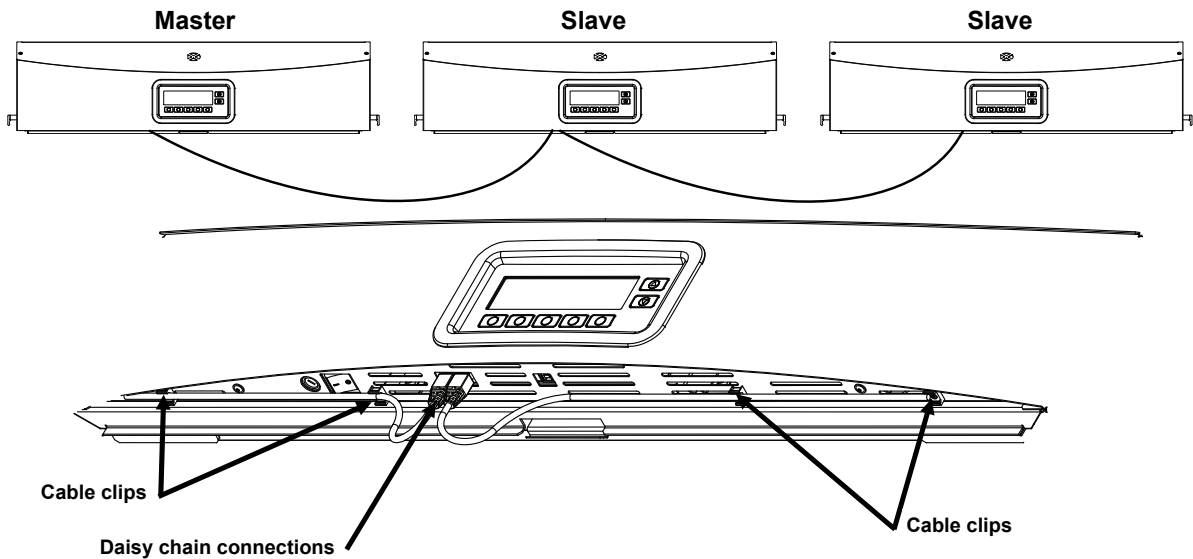

Figure 11. Luminaire Daisy Chain Connection



CAUTION: Before plugging in the unit, verify the voltage indicated on the SpectraLight QC back label complies with the AC line voltage in your area. If not, contact X-Rite or an authorized representative.

10. Plug the SpectraLight QC into an AC wall outlet.
11. Refer to the User Interface section for information on powering up, usage, and daisy chain configuration.

NOTE: Always switch the power “ON” of the ‘Slave’ units first and the ‘Master’ unit last. Units configured as ‘Slaves’ cannot be addressed independently.

Powering Up

Toggle the main power switch under the front edge of the panel to the left to turn on the unit.

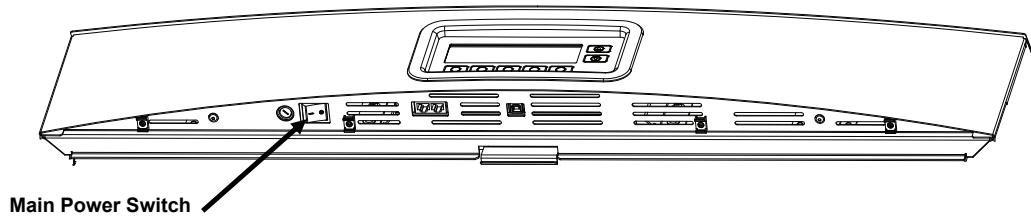

Immediately after power up, the unit will go through a brief system test. After the test, the main menu will appear on the screen. The clock on the main menu will initially appear faded, and the date and time for the system must be set to operate the lamps. Refer to the Administrator section later in this manual for the procedure.



NOTE: When powering-off the SpectraLight QC, wait at least 5 seconds for proper shutdown before powering-on again. If you attempt a power on less than 5 seconds after shutdown, the unit may not power-on. If this occurs, shutdown the unit, wait at least 5 seconds, and then power it on using the power switch.

Navigating the Screen

The five switches at the bottom of the display panel are used to select lamp sources, advance to additional screens, and perform editing functions. The option displayed above each switch is what is selected when the switch is pressed.

For example, if the leftmost switch is pressed in the example to the right, the daylight illuminate would turn on.

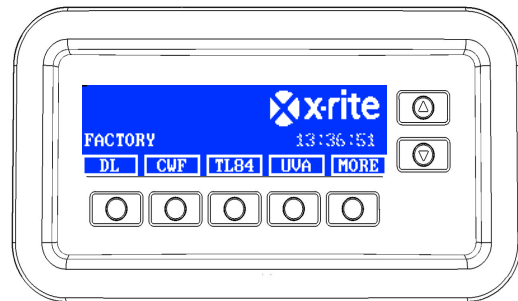

The up (▲) and down (▼) arrow switches on the right are used to scroll through available functions and options or adjust values. Items become highlighted when selected.

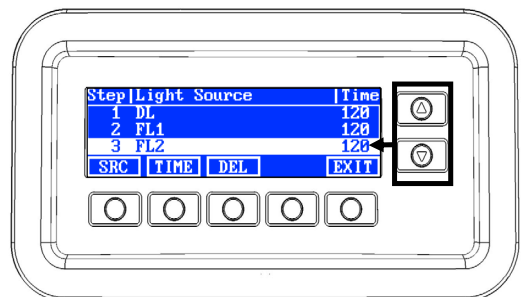

NOTE: Refer to the Appendix section to view a complete flowchart of the SpectraLight QC user interface command menu.

SpectraLight QC Software Utility

The SpectraLight QC comes with a software utility that allows you to perform configuration setup and operate the unit from a computer. The application can also be used to create customer performance reports.

System Requirements

- Windows 7 (32 or 64 bit), RAM 1 GB
- Windows 10 (32 or 64 bit), RAM 1 GB
- Monitor screen resolution of 1024 x 768
- 1 GB hard disk free

Software Installation

IMPORTANT: You must be logged on as an administrator or a member of the Administrators group in order to install the application on a computer with Windows 7 or 10 Operating System.

1. Insert the software CD into the optical drive and double-click the **Installer.exe** file on the CD.
2. Follow the on screen prompts to install the software.

SYSTEM SETUP (ADMIN)

Setup mode is used to adjust and view the unit settings. You should set and view the settings before using the unit for the first time. However, you can go back and change these settings at any time. Each setting is explained on the following pages.

The ADMIN menu is used to configure owner, system, relamp, profile, operator, and time settings.

NOTE: If you intend on using the SpectraLight QC software utility to configure the unit, attach the USB cable from the computer to the USB port under the edge of the front panel. Launch the SpectraLight QC application utility (Programs->X-Rite->SPL QC). Select the “**Configuration**” check box and click the **MORE** switch. Selecting the “Configuration” check box simulates holding the button to access the Setup screen.

1. From the main menu of the SpectraLight QC, press and hold the **MORE** switch until Setup appears in the display screen.



2. Press the **ADMIN** switch to access the Advance Setup 1 screen.

NOTE: If password protection was previously setup, you will need to enter the password before accessing the ADMIN options.



Owner Profile Setup (OWNER)

1. Press the **OWNER** switch to access the Owner screen.



The following are descriptions of the Owner Options.

Owner Options	Text Entry	Factory Default	Description
Company	Text	Blank	Enter company name with a maximum of 15 characters. The name appears on the reports.
Department	Text	Blank	Enter department name with a maximum of 15 characters. The name appears on the reports.
Location	Text	Blank	Enter location name with a maximum of 15 characters. The name appears on the reports.
Brand	Text	Blank	Enter brand name with a maximum of 15 characters. The name appears on the reports.
Remarks	Text	Blank	Enter a note with a maximum of 15 characters. The remarks appear on the reports.
Admin Password	Text	Blank	Enter a new password with a maximum of 15 characters. Password protection is activated or deactivated in the Systems Settings.

- Use the up (▲) and down (▼) arrow switches to highlight the desired option.
- After the option is highlighted, press the **EDIT** switch to access the editing screen.

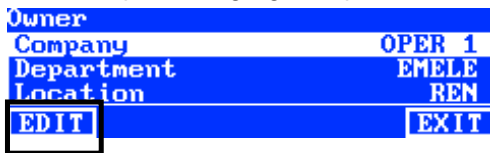

- Enter required text or select desired option for the owner options. Refer below for additional information on editing the owner options.

Entering text using the front panel:

- Use the left (◀), right (▶), up (▲), and down (▼) arrow switches to highlight the letter/number in the list.
- Use the **BACK** switch to delete one character at a time.
- Press the **ENTER** switch to add the character to the name.



- Continue with additional letter/numbers until the name is complete.
- Press the **DONE** switch and then the **Yes** switch when finished.

Entering text using the application:

- Make sure the editing window is displayed and enter required name (15 characters maximum).
- Press **Enter** key on the keyboard when finished.

- When finished with owner options, press the **EXIT** switch to exit the Owner screen.

Primary System Settings (SYS)

- Press the **SYS** switch to access the System Settings screen.



The following are descriptions of the system settings.

System Settings	Value or option selection	Factory Default	Description
DL + UV	Auto, Manual	Auto	Automatic add UV to daylight or manually add UV to daylight.
Dim Reference	Voltage, Lux	Lux	Set fluorescent lamp dim control by lux or by voltage. UV is always dimmed by voltage. LED lamps are NOT compatible with the SPLQC's dimming functionality. However, the LED lamps can be reliably operated without dimming. Make sure the "Dim Reference" is set to "Voltage". When operating with LED Lamps, repeatedly press the "Up" arrow button until dimming voltage 10.50 V is displayed.
Filter	D50, D65	D50 or D65 (depending	NOTE: The filter is set at the factory for a specific model. This setting should only change if the

		on model)	installed filter is changed by an authorized service technician.
Up/Down keys	Dim Control, Tri Lux, LCD Control	Dim Control	Set up and down switches to be used for Dim control, Tri Lux or LCD brightness/contrast control. Make sure the Up/Down keys is set to Dim Control when LED lamps are installed.
Acoustic Signal	Enabled, Disabled	Disabled	Enable or disable an audible signal to occur when a message appears on the front panel.
Sensor Monitor	Enabled, Disabled	Disabled	When enabled it displays lamp, input, temp., etc. sensor data in main menu. Use the up (▲) and down (▼) arrow switches to view the data.
Switch Name	Generic, Lamp Type	Lamp Type	Allows you the option to display the type of lamp used (i.e., TL84, CFW, etc.) or display the generic lamp name (i.e., FL1, FL2, etc.) that appears above the switches.
EOL Pre-warning	Off, 80%, 85%, 90%, 95%	Off	Set end of lamp life (EOL) pre-warning percentage.
Time Format	12H, 24H	24H	Set time format.
Operation Mode	SPL QC, Control Box	SPL QC	Set the SPLQC or control box mode. Select "Control Box" mode if you are setting up a control box.
Password	Disabled, Enabled	Disabled	Enable or disable password protection for the Administration (ADMIN) Setup.
RF Remote	Disabled, Enabled	Disabled	Enable or disable the use of the optional remote control.
RF Remote Addr.	0 to 7	0	Set remote control address code to match the remote control dipswitch setting. Refer to the Remote Control Operation section later in this manual to setup the remote control.
Auto-Off Timer (min)	0 to 999 minutes	5	Set the amount of time in minutes that the DL, HZ, and HL lamps change to the FL1 lamp. Set to "0" if you do not want the lamp change.
Standby Timer (min)	0 to 999 minutes	30	Set the amount of time in minutes that the unit goes into standby after the last button was pressed. Any button pressed on the display panel will reactivate the unit.
Message Codes	0 to 255	100	Messages appear on the display as codes; 1-99 for Error and Warning, 100-255 for information.
Message Repeat	0 to 100	0	Number of times the same message will appear on the display before it ends.
Key Repeat Time(ms)	100 to 999	200	Set key automatic repeat interval. Press and hold the key will produce multi-click events.

- Use the up (▲) and down (▼) arrow switches to highlight the desired option.
- After the option is highlighted, press the **EDIT** switch to access the editing screen.

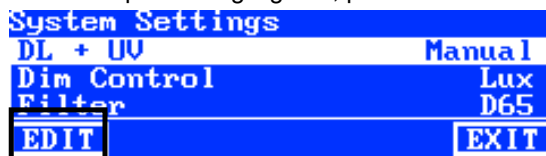

- Select desired option or value for the system settings. Refer below for additional information on editing the system settings.

To select option or value:

- Use the up (▲) and down (▼) arrow switches to highlight the option or select a value.



- Press the **OK** switch to save the selected option/value.
5. When finished with the system settings, press the **EXIT** switch to exit the System Settings screen.

Reset Lamp Hour Counter and Lifetime (RLAMP)

The Relamp screen displays the hours and cycles remaining for each lamp in the system. From this screen, the user can reset hours/cycles, select type of lamp, change EOL (End Of Life) parameters and add lamp serial numbers.

1. Press the **RLAMP** switch to access the Relamp screen.



2. Use the up (▲) and down (▼) arrow switches to view the hours/cycles remaining for each lamp.

Lamp	Type	Remain	Hours	Cycles
DL	DL	6500K	200.0	63982
FL1	CFW		2000.0	9969
FL2	TL84		2000.0	9987

Below the table are menu options: **RESET**, **TYPE**, **SN#**, **EOL**, and **EXIT**.

NOTE: The ALL option displays the sum of all lamps hours and cycles.

Resetting Hours/Cycles

This option is used to reset the lamp hours and cycles after a new lamp is installed.

1. To reset, use the up (▲) and down (▼) arrow switches to highlight desired lamp.
2. Press the **RESET** switch and then the **YES** switch to reset the numbers.
3. Press the **EXIT** switch to exit the screen.

Selecting Type of Lamp

Select the lamp type installed from the list. If the lamp type is not in the list, please consult your technical support. **NOTE:** This setting should only be used if changing the lamp type from the factory configuration.

1. To set type, use the up (▲) and down (▼) arrow switches to highlight the lamp location.
2. Press the **TYPE** switch to access the Select Type screen.



3. Use the up (▲) and down (▼) arrow switches to highlight the lamp type.
4. Press the **OK** switch to save the selected type to the lamp location.

Entering a lamp serial number

A lamp serial number can be a maximum of 15 characters. The number to enter is a Macbeth alphanumeric number located on the lamp or lamp packaging.

1. To enter a serial number, use the up (▲) and down (▼) arrow switches to highlight the lamp location.
2. Press the **SN #** switch to access the serial number screen.



- Use the up (▲) and down (▼) arrow switches to highlight the lamp location.
 - DL select the left or right lamp location.
 - F1, F2, F3, and UV select the front or rear lamp location.
 - HZ select front 1, front 2, rear 1, or rear 2 lamp location.
 - LED lamps can be installed at FL1 front and rear lamp location.

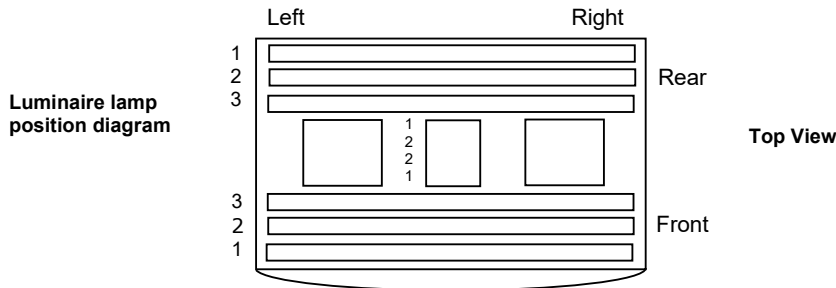

- Press the **EDIT** switch to access the editing screen.
- Enter the required serial number (see below).

Entering serial number using the front panel:

- Use the left (◀), right (▶), up (▲), and down (▼) arrow switches to highlight the letter/number in the list.
- Press the **ENTER** switch to add it to the name.



- Continue with additional letter/numbers until the number is complete.
- Press the **DONE** switch and then the **Yes** switch when finished.

Entering serial number using the application:

- Make sure the editing window is displayed and enter required serial number.
- Press **Enter** key on the keyboard when finished.

NOTE: The DEL option is used to delete the current lamp serial number from the selected lamp location.

Setting EOL Parameters

This option is used to set the end of life parameters for each lamp. When the hours or cycles are reached for the lamp, an EOL message appears on the main menu when the lamp is turned on. If the EOL lamp option is disabled, no message appears.

NOTE: This setting should only be used if changing the EOL from the factory configuration.

- To set EOL, use the up (▲) and down (▼) arrow switches to highlight the lamp location.
- Press the **EOL** switch to access the EOL screen.

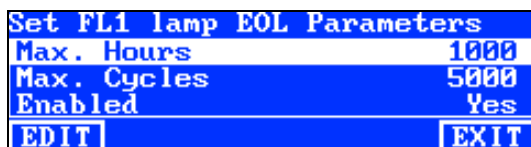

3. Use the up (▲) and down (▼) arrow switches to highlight the desired parameter.
4. Press the **EDIT** switch to access the editing screen.
5. Use the up (▲) and down (▼) arrow switches to enter desired hours, cycles or enabled/disabled option.
NOTE: Holding down the switch quickly increments through the values.
6. Press the **OK** switch to save.
7. Press the **EXIT** switch to exit the screen.

Create Operator Profiles (PROFL)

The profile screen is used to create up to 16 profiles. Once created, you can customize the switches and setup an auto sequence. Individual profiles are then selected through the User Settings screen.

1. From the Advanced Setup 1 screen, press the **MORE** switch to access the Advanced Setup 2 screen.



2. Press the **PROFL** switch to access the Profile List screen.



3. See Creating a profile and editing a profile procedures that follows.

Creating a Profile by Copying the Factory Profile

1. Use the up (▲) and down (▼) arrow switches to highlight “Factory” and press the **COPY** switch.
2. Use the up (▲) and down (▼) arrow switches to highlight the next available “Free” location for a new profile.



3. Press the **PASTE** switch and then the **Yes** switch, and edit the profile name as needed (see below).
4. Edit the remaining profile parameters. See Editing a Profile that follows.

Copying an Existing Profile

1. If you want to copy an existing profile, highlight the profile and press the **COPY** switch. The profile will be used as the template for the new profile.
2. Use the up (▲) and down (▼) arrow switches to select the location to copy the profile. This can be a “free” location or you can overwrite an existing profile location.
3. Press the **PASTE** switch and then the **Yes** switch to paste a copy of the selected profile to the new location.
4. Edit the name of the new profile as needed and then edit the parameters. See Editing a Profile that follows.

Entering name using the front panel:

- Use the left (◀), right (▶), up (▲), and down (▼) arrow switches to highlight the letter/number in the list.
- Use the **BACK** switch to delete one character at a time.
- Press the **ENTER** switch to add the character to the name.



- Continue with additional letter/numbers until the name is complete.
- Press the **DONE** switch and then the **Yes** switch when finished.

Entering text using the software application:

- Make sure the editing window is displayed and use the **Backspace** key to delete one character at a time.
- Enter required name (15 characters maximum).
- Press **Enter** key on the keyboard when finished.

Deleting Profiles

1. To delete a profile, use the up (▲) and down (▼) arrow switches to highlight the profile.
2. Press the **DEL** switch and then the **YES** switch to delete the profile.

Editing a Profile

After creating a profile, you can customize the switches and setup an auto sequence.

1. Use the up (▲) and down (▼) arrow switches to highlight the profile that you wish to edit.



2. Press the **EDIT** switch to access the Edit Profile screen.

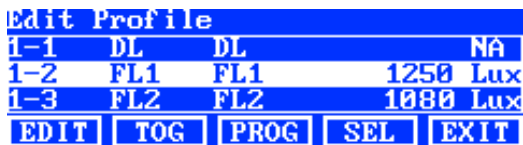

3. Enter the required parameters (see below).
4. When finished, press the **EXIT** switch to exit the Edit Profile screen.

Single Lamp “Tri Lux” Operation (fluorescent tubes only)

The Edit screen is used to edit the high, normal and low lamp lux values. The “Norm” lux value is used for standard operation. The “Tri Lux” option must be selected for the “Up/Down keys” option in System Setting to allow the three lux selection during operation.

1. Press the **EDIT** switch to access the Preset Lux Values screen.

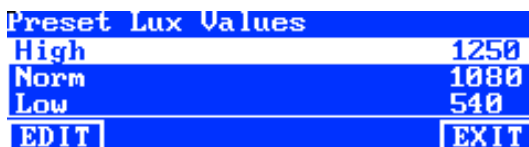

2. Use the up (▲) and down (▼) arrow switches to select High, Norm, or Low.
3. Press the **EDIT** switch to access the change lamp lux value screen.



4. Use the up (▲) and down (▼) arrow switches to select a value.
5. Press the **OK** switch when finished.
6. Continue with other lux preset if required.

Enable/Disable Lamp Switches (TOG)

The Toggle function is used to enable or disable switches on the two main menu screens.

1. Use the up (▲) and down (▼) arrow switches to highlight the switch you want to disable or enable.
2. Press the **TOG** switch to enable or disable the switch. (**NOTE:** Disabled switches appear grayed out in this screen and do not appear on the main menus).
3. Continue with additional switch settings.

Moving Lamp Switch Order and Auto-Sequencing the Light Sources (SEL)

The Select function is used to set the lamp switch locations on the two main menu screens. The “1-1” position refers to main menu screen 1 and switch number 1 (left switch). The “1-2” position refers to main menu screen 1 and switch number 2 position and so on. Refer to the following page for switch location details.

1. Use the up (▲) and down (▼) arrow switches to highlight the switch to move.
2. Press the **SEL** switch. The highlight over the selected switch flashes indicating it is selected.
3. Use the up (▲) and down (▼) arrow switches to move the switch name (i.e., DL) to the desired menu location.
4. Press **SEL** switch again to set the location.
5. Continue with additional switch locations.

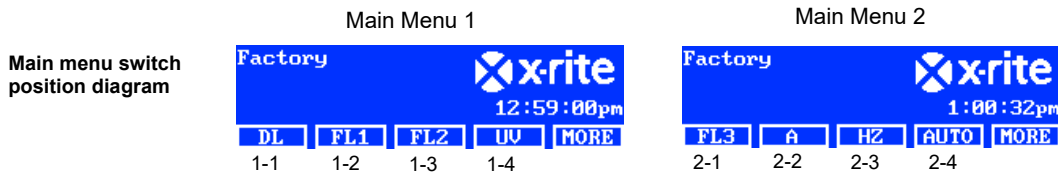

Setup Auto Sequence (PROG)

The SpectraLight QC can be programmed to run a sequence of light sources for the selected profile, each for a specified period of time (1-999 seconds).

1. Press the **PROG** switch to access the auto sequence screen for the selected profile.
2. Use the up (▲) and down (▼) arrow switches to highlight step 1 on the screen.
3. Press the **SRC** switch to access the Select Source screen.

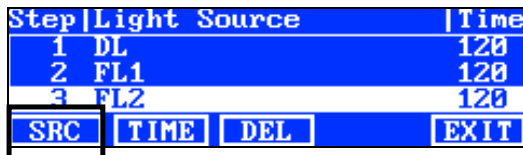

4. Use the up (▲) and down (▼) arrow switches to highlight the desired lamp source for step 1 in the sequence. If no source is required for the step, select **OFF**. Press the **OK** switch to save selection and exit.

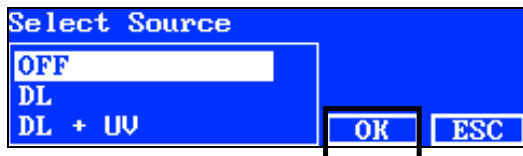

5. Press the **TIME** switch to access the Change Time screen.

Use the up (▲) and down (▼) arrow switches to select the amount of time in seconds that the first lamp will remain on. **NOTE:** Holding down the switch quickly increments through the values.

- Press the **OK** switch to save selection and exit.



- Repeat steps 2 through 6 to add additional lamps to the sequence. A total of 10 steps can be added to the sequence.
- Steps not required can be selected and deleted by pressing the **DEL** switch and then the **YES** switch. When finished, press the **EXIT** switch to exit the auto sequence program screen.

Edit Operator Profiles (OPER)

The operator screen allows you enter specific information for up to 16 operators. The operator information will print in the report.

- From the Advanced Setup 1 screen, press the **MORE** switch to access the Advanced Setup 2 screen.



- Press the **OPER** switch to access the Operator List screen.



Editing Operators

- Use the up (▲) and down (▼) arrow switches to highlight the desired operator.



- Press the **EDIT** switch at access the Edit Operator screen.

The following are descriptions of the Operator Options.

Operator Options	Text Entry Value, or Option	Factory Default	Description
Name	Text	Blank	Enter operator name with a maximum of 15 characters.
ID	Text	Blank	Enter operator ID with a maximum of 15 characters. The ID appears on the reports.
Gender	Male, Female	Blank	Select operator gender.
Year born	1900 - 2050	1900	Select operator date of birth.
FM100 Test	0 to 100	0	Munsell Farnsworth FM100 Hue Test FM100 is "Total Error Score., A perfect score is 0. Some US apparel brands require a score of 0-16 for staff/partners who evaluate color.
Ishihara Test	0 to 100	0	The Ishihara test consists of a number of

			colored plates. The plates are graded individually and it is the series of plates that results in the overall assessment.
Optional Score 1	0 to 7	0	User defined
Optional Score 2	0 to 7	0	User defined

- Use the up (▲) and down (▼) arrow switches to highlight the desired option.
- After the option is highlighted, press the **EDIT** switch to access the editing screen.

```

Edit Operator
Name          OPERATOR II
ID            J88
Gender        Male
EDIT         EXIT
  
```

- Select desired option/value or enter text.

To select option or value:

- Use the up (▲) and down (▼) arrow switches to highlight the option or select a value.
- Press the **OK** switch to save the selected option/value.

Entering text using the front panel:

- Use the left (◀), right (▶), up (▲), and down (▼) arrow switches to highlight the letter/number in the list.
- Use the **BACK** switch to delete one character at a time.
- Press the **ENTER** switch to add the character to the name.

```

_          ABCDEFGHIJK
           LMNOPQRSTUW
           WXYZ #*:/+-
           .0123456789
BACK ENTER DONE <- ->
  
```

- Continue with additional letter/numbers until the name is complete.
- Press the **DONE** switch and then the **Yes** switch when finished.

Entering text using the software application:

- Make sure the editing window is displayed and enter required name (15 characters maximum).
- Press **Enter** key on the keyboard when finished.

Date and Time Setup (TIME)

The time screen is used to set the current time and date for the system.

NOTE: You must initially set the date and time before any lamps will operate.

- From the Advanced Setup 1 screen, press the **MORE** switch to access the Advanced Setup 2 screen.

```

Advanced Setup 1  x-rite
OWNER SYS RLAMP MORE EXIT
  
```

- Press the **TIME** switch to access the Time screen.

```

Advanced Setup 2  x-rite
PROFL OPER TIME MORE EXIT
  
```

- Use the **BACK** switch to move the cursor to the desired parameter.

- Use the left (◀), right (▶), up (▲), and down (▼) arrow switches to select the date/time parameter.



- Press the **ENTER** switch to select.
- Continue with additional parameters.
- When finished, press the **DONE** switch and then the **YES** switch to set the date/time and exit the Time screen.

User Settings (USER)

The USER menu is used to configure the operator, profile, attenuator, language, brightness, and contrast settings.

NOTE: If you intend on using the SpectraLight QC software utility to configure the unit, attach the USB cable from the computer to the USB port under the edge of the front panel. Launch the SpectraLight QC application utility (Programs/X-Rite/SPL QC). Select the “**Configuration**” check box and click the **MORE** switch.

- From the main menu of the SpectraLight QC, press and hold the **MORE** switch until Setup appears in the display screen.



- Press the **USER** switch to access the User Settings screen.



The following are descriptions of the user settings.

User Settings	Value or option selection	Factory Default	Description																				
Operator	1 to 16		Select the operator from the list. Operator name will appear on the main menu.																				
Profile	1 to 16		Select the profile from the list. Profile name will appear on the main menu.																				
Attenuator	75%, 50%, 25%, 0%	25% - D65 50% - D50	<p>NOTE: Make sure the setting matches the attenuator cover installed otherwise the system will not work properly. Refer to the Appendices for the procedure.</p> <table border="1"> <thead> <tr> <th colspan="5">Lux Output</th> </tr> <tr> <th>Attenuator</th> <th>0%*</th> <th>25%</th> <th>50%</th> <th>75%</th> </tr> </thead> <tbody> <tr> <td>D50</td> <td>3000</td> <td>2000</td> <td>1400</td> <td>900</td> </tr> <tr> <td>D65</td> <td>2000</td> <td>1400</td> <td>1000</td> <td>500</td> </tr> </tbody> </table> <p>+/- 200 Lux all lamps * No attenuator</p>	Lux Output					Attenuator	0%*	25%	50%	75%	D50	3000	2000	1400	900	D65	2000	1400	1000	500
Lux Output																							
Attenuator	0%*	25%	50%	75%																			
D50	3000	2000	1400	900																			
D65	2000	1400	1000	500																			
Language	English, Chinese	English	Select the preferred user interface language.																				
Brightness	0 to 100%	100%	Adjust the brightness of the LCD display.																				
Contrast	0 to 63	32	Adjust the contrast (viewing angle) of the LCD display.																				

- Use the up (▲) and down (▼) arrow switches to highlight the desired option.
- After the option is highlighted, press the **EDIT** switch to access the editing screen.



- Select desired option or value for the user setting.

To select option or value:

- Use the up (▲) and down (▼) arrow switches to highlight the option or select a value.

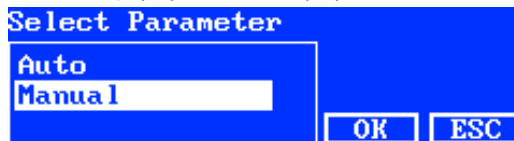

- Press the **OK** switch to save the selected option/value.

- When finished with the user settings, press the **EXIT** switch to exit the User Settings screen.

Display System Information (INFO)

The System Info screen is used to view the current system information (i.e., versions, calibration status, daisy device serial number, etc.). A system log file can also be viewed from this screen.

- From the main menu of the SpectraLight QC, press and hold the **MORE** switch until Setup appears in the display screen.



- Press the **INFO** switch to access the System Info screen.



- Use the up (▲) and down (▼) arrow switches to view all system information.
- The system information is displayed. Press the **LOG** switch to view the last 1024 log file entries.



- When finished, press the **EXIT** switch to exit the System Info screen.

NOTE: The **TEST** switch is used to run a lamp test on the system. The test results are stored in the unit and can be output at a later time by the software application to generate a test report.

Daisy Chain Configuration Setup (CHAIN)

The daisy chain screen is used to configure the luminaires that are connected together. A maximum of 64 luminaires can be daisy chained. If an optional control box will be used to operate the daisy chained units, refer to the Optional Control Box section later in this manual for the installation procedure.

1. Connect the required luminaires together. Refer the Overhead luminaire Installation section earlier in this manual for the procedure.
2. From the main menu of the SpectraLight QC, press and hold the **MORE** switch until Setup appears in the display screen.



3. Press the **CHAIN** switch to access the Chain Setup screen.



The following are descriptions of available daisy chain settings.

Settings	Option selection	Default	Description
Daisy Chain	Enabled, Disabled	Enabled	Enable or disable daisy chain operation
Bus Mode	Serial, Parallel	Serial	Set bus operation mode to serial or parallel.
Address Mode	Broadcast, Group, Device	Broadcast	Set addressing mode option for the luminaires. Broadcast covers all connected unit. Group covers the selected group and Device is for an individual unit.
Group	G1 to G8	G1	Set the active group for addressing a subset of luminaires.
Device	1 to 64	1	Set the luminaire location for device addressing.

4. Use the up (▲) and down (▼) arrow switches to highlight the desired option.
5. After the option is highlighted, press the **EDIT** switch to access the editing screen.



6. Select desired option from the available daisy chain settings.

To select option:

- Use the up (▲) and down (▼) arrow switches to highlight the option.

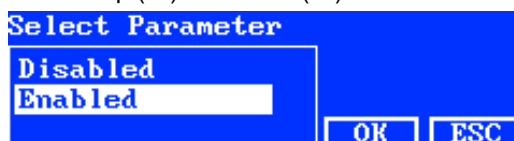

- Press the **OK** switch to save the selected option.
 - Press the **EXIT** switch to exit the daisy chain settings screen.
7. After the chain cabling or chain enabled restart, the system will get the chain enumerated.

Group Screen

This option is used to assign devices (luminaires) to specific groups.

1. To assign a group to devices, press the **GROUP** switch.
2. Use the up (▲) and down (▼) arrow switches to select a device.
3. Press the **EDIT** switch and use the up (▲) and down (▼) arrow switches to select a group.
4. Press **OK** to confirm the assignment.
5. When finished, press the **EXIT** switch to exit the daisy chain settings screen.

NOTE: The **BREAK** switch is used to send a “break” signal to the daisy chain. This function is used for servicing.

NOTE: Always switch the power “ON” first to the ‘Slave’ units and the ‘Master’ unit last. Units configured as ‘Slaves’ cannot be addressed independently.

OPERATION

Selecting a Lamp Source

NOTE: Disable the “auto-off” feature by pressing and holding the DL, A, or HZ light source switch for 2 seconds. You will hear a second click and see **Nonstop** appear in the display screen.

The main menu consists of two screens for selecting lamp sources.

Momentarily pressing the **MORE** switch toggles between the two main menu screens.

Momentarily pressing a lamp source switch will turn on the lamp source. The source remains on until you select another lamp source or press the lamp source switch again.

Daylight, Halogen, or Horizon lamps will also turn off if the “auto-off” time is reached (default time of 5 minutes). This feature is helpful if a user leaves the booth with any of these three sources selected and does not switch to another source. Refer User Settings in the Configuration to adjust the “auto-off” timer.

NOTE: Lamps will not operate until the date and time for the system are set. Refer to the Administrator section earlier in the Manual for instructions.

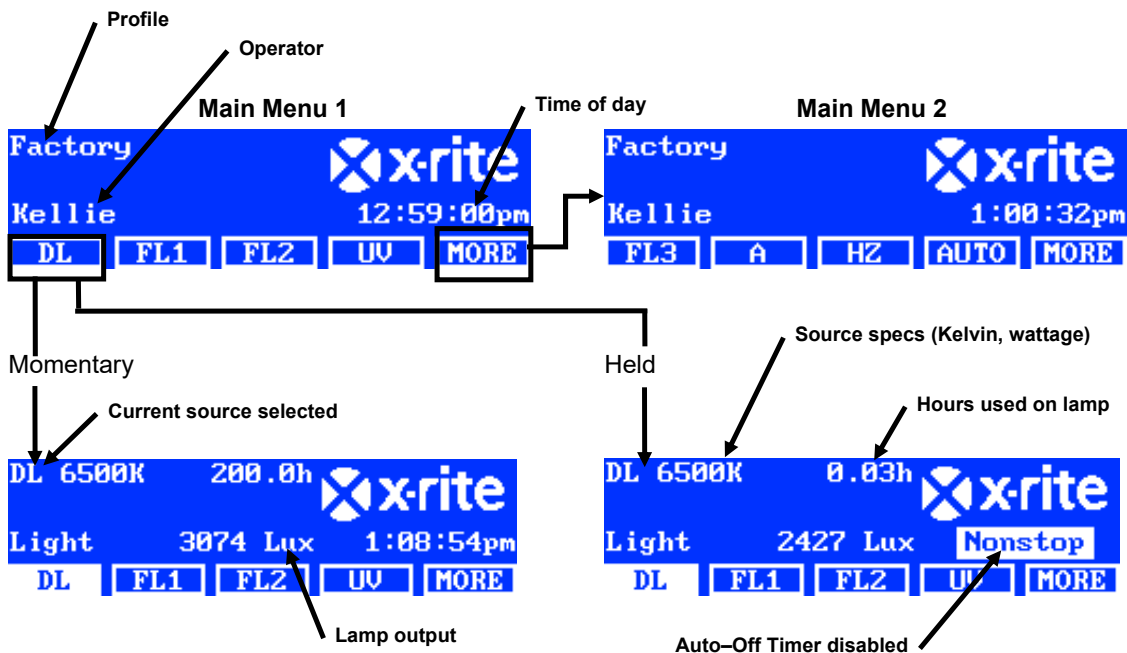

The Dim control allows you to increase or decrease the Lux or brightness of only the fluorescent and lamp sources. The Dim control is also used to set the voltage to 10.50V for LED lamps. The Tri Lux option allows you to page through three predefined lux values set for the profile.

When a fluorescent or UV lamp is activated, continually press the up (▲) switch or down (▼) switch to increase or decrease the output. When dimming occurs, any profile that was set will be exited and the name will disappear from the main menu, unless the admin changes the selection.

When a LED lamp is activated, continually press the up (▲) switch until dimming voltage 10.50V is displayed.

NOTE: Dim control or Tri Lux must be selected as the “up/down keys” option in System Setting for this function.

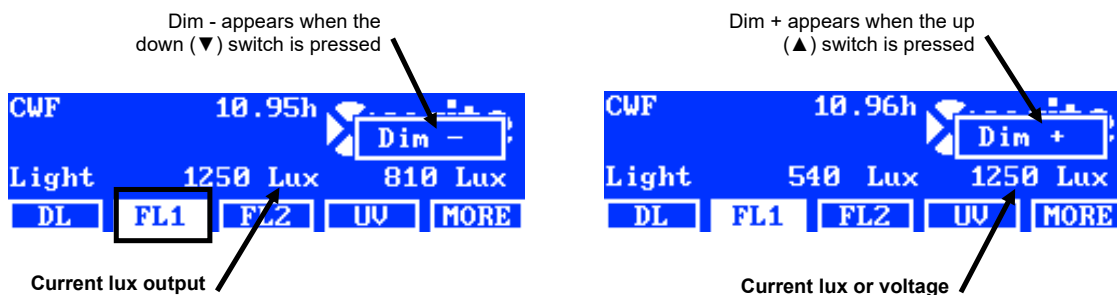

Description of the switches located on the two main menus

- DL:** Turns on/off Daylight source
DL (held): Turns on Daylight in nonstop mode (disables auto-off)
A: Turn on/off Incandescent A Lamp
A (held): Turns on Incandescent A Lamp in nonstop mode (disables auto-off)
UV: Turns on/off UV Lamp
HZ: Turns on/off Horizon Lamp
HZ (held): Turns on Horizon Lamp in nonstop mode (disables auto-off)
FL1: Turns on/off Fluorescent Lamp 1 or LED Lamp 1
FL2: Turns on/off Fluorescent Lamp 2
FL3: Turns on/off Fluorescent Lamp 3
AUTO: Run Automatic Sequence (see Automatic Sequence later in this manual)
AUTO (held): Edit Automatic Sequence (see Automatic Sequence later in this manual)
MORE: Toggles between Main Menu 1 and Main Menu 2
MORE (held): Enters Configuration Menu (see Configuration section earlier in this manual)
NOTE: The generic fluorescent lamp names (FL1, FL2, and FL3) can be replaced with the lamp type name (CWF, TL84, LED, etc.) if desired. Refer to the Switch Naming option procedure earlier in User Settings.

Auto Sequence

The SpectraLight QC can be programmed to run a sequence of light sources, each for a specified period of time (1-999 seconds). The program is helpful if you want to view a sample under several light sources in succession and focus on the sample's appearance rather than manually changing light sources.

NOTE: Changing the Auto Sequence at the main menu will cause any profile that was set to exit and the name to disappear from the main menu.

Programming an Auto Sequence

- From the main menu, press and hold the **AUTO** switch until the auto sequence program screen appears in the display panel.



- Use the up (▲) and down (▼) arrow switches to highlight step 1 on the screen.
- Press the **SRC** switch to access the Select Source screen.

Step	Light Source	Time
1	DL	120
2	FL1	120
3	HZ	120

Below the table are four buttons: "SRC", "TIME", "DEL", and "EXIT". The "SRC" button is highlighted with a white border.

- Use the up (▲) and down (▼) arrow switches to highlight the desired lamp source for step 1 in the sequence. If no source is required for the step, select **OFF**. Press the **OK** switch to save selection and exit.

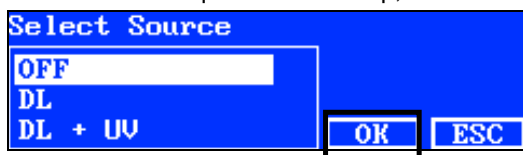

- Press the **TIME** switch to access the Change Time screen.
Use the up (▲) and down (▼) arrow switches to select the amount of time in seconds that the first lamp will remain on. **NOTE:** Holding down the switch quickly increments through the values.

- Press the **OK** switch to save selection and exit.

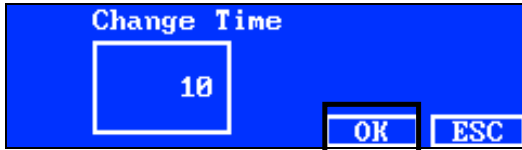

- Repeat steps 2 through 6 to add additional lamps to the sequence. A total of 10 steps can be added to the sequence.
- Steps not required can be selected and deleted by pressing the **DEL** switch.
- When finished, press the **EXIT** switch to exit the auto sequence program screen.

Running an Auto Sequence

From the main menu 2, press the **AUTO** switch to start the auto sequence program. The sources are powered in the sequence you programmed and will stop after the last source is finished.

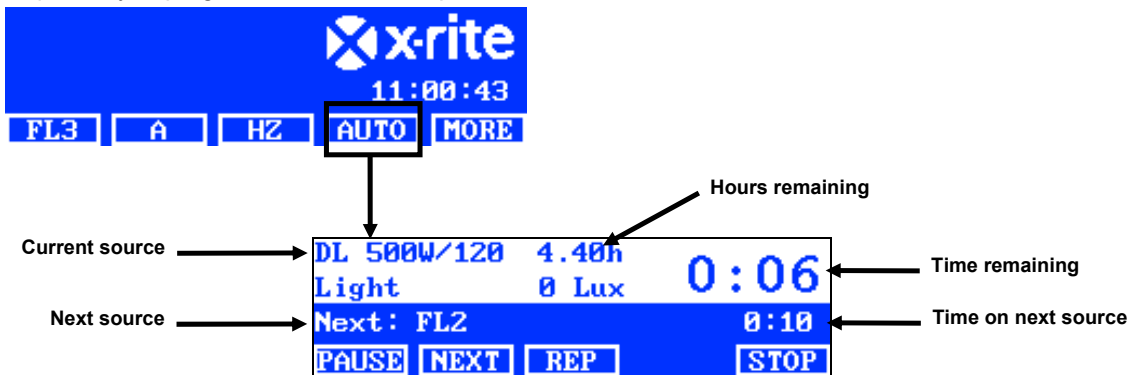

Description of the switches located on the auto sequence menu

- PAUSE:** Pauses the sequence and leave the current light source on. Pressing the switch again resumes the sequence. This is useful if you want to the light source to remain on longer than it's programmed.
- NEXT:** Advances to the next source in the sequence.
- REP:** Repeats the sequence after it is completed.
- STOP:** Stops the sequence and exits the program.

Display Adjustment

The brightness and contrast of the display panel can be adjusted to meet your viewing requirements.

NOTE: The display can only be adjusted using the up (▲) and down (▼) arrow switches, and if the "LCD Control" option is enabled and the Sensor Monitor option is disabled in the System Settings. Refer to the System Settings section earlier in this manual for details. The LCD display can always be adjusted in the User Settings.

- Select the main menu 1 screen for brightness adjustment or the main menu 2 screen for contrast adjustment.
- Use the up (▲) and down (▼) arrow switches to adjust the brightness or contrast.

Sensor Display (for service only)

The sensor display feature displays various lamp, input, temp., etc. sensor data in main menu screens.

NOTE: The sensor data can only be viewed if the “Sensor Monitor” option in the System Settings is enabled. Refer to the System Setting section earlier in this manual for details.

1. Use the up (▲) and down (▼) arrow switches to select the desired sensor data screen.
2. Select the desired lamp source from main menu.

```

Power module:
Lamp:      1.1V      13.3W
Input:    211.9V     0.1A
PWM: 0    VoltRef: 0.0V
FL3 | A | HZ | AUTO | MORE

```

NOTE: You cannot change the sensor screen if a visible switch is active. In this case use MORE to go to next main screen.

System Operating Language

The operating language of the unit can be set at the main menu level without the need to enter the Configuration mode.

1. Make sure the main power switch is off.
2. Press and hold the up (▲) arrow switch and turn on the main power switch under the front edge of the luminaire. Hold the arrow switch until the language menu appears.
3. Use the up (▲) and down (▼) arrow switches to highlight the desired language and then press the **OK** switch.

Running System Reports

The SpectraLight QC application can produce a conformance report and lamp report on the system. Refer to the pages that follow for detail information of the reports.

1. Launch the SpectraLight QC application (Programs->X-Rite->SPL QC).

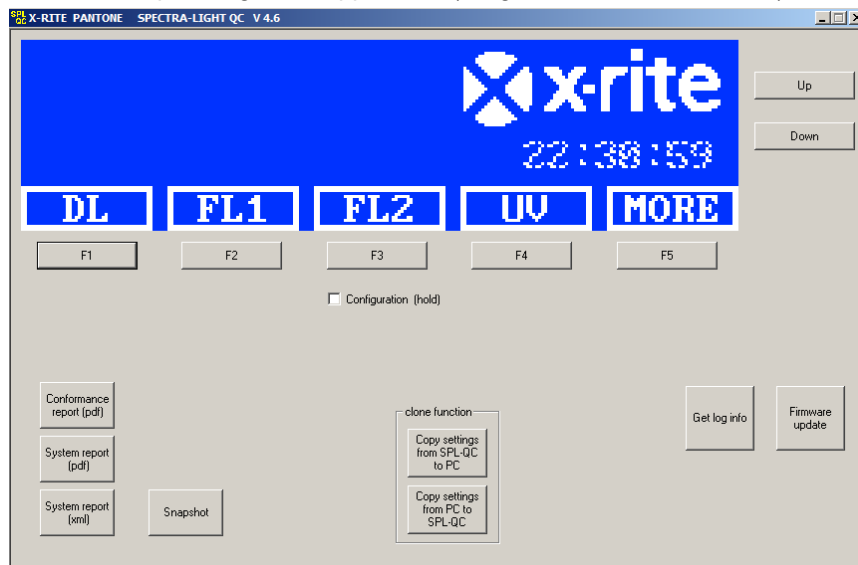

System Report

Before viewing a new system report, you must run a test on the lamps. The lamp test will take up to 10 minutes to complete. Refer to the System Information (INFO) section earlier in this manual for the procedure.

2. Click the **System Report** (pdf or xml) button to run and view a report on all the system lamps.

Conformance Report

Select the required operator and profile before running the conformance report.

- Click the **Conformance Report** button to create and view a conformation report.

Sample System Report

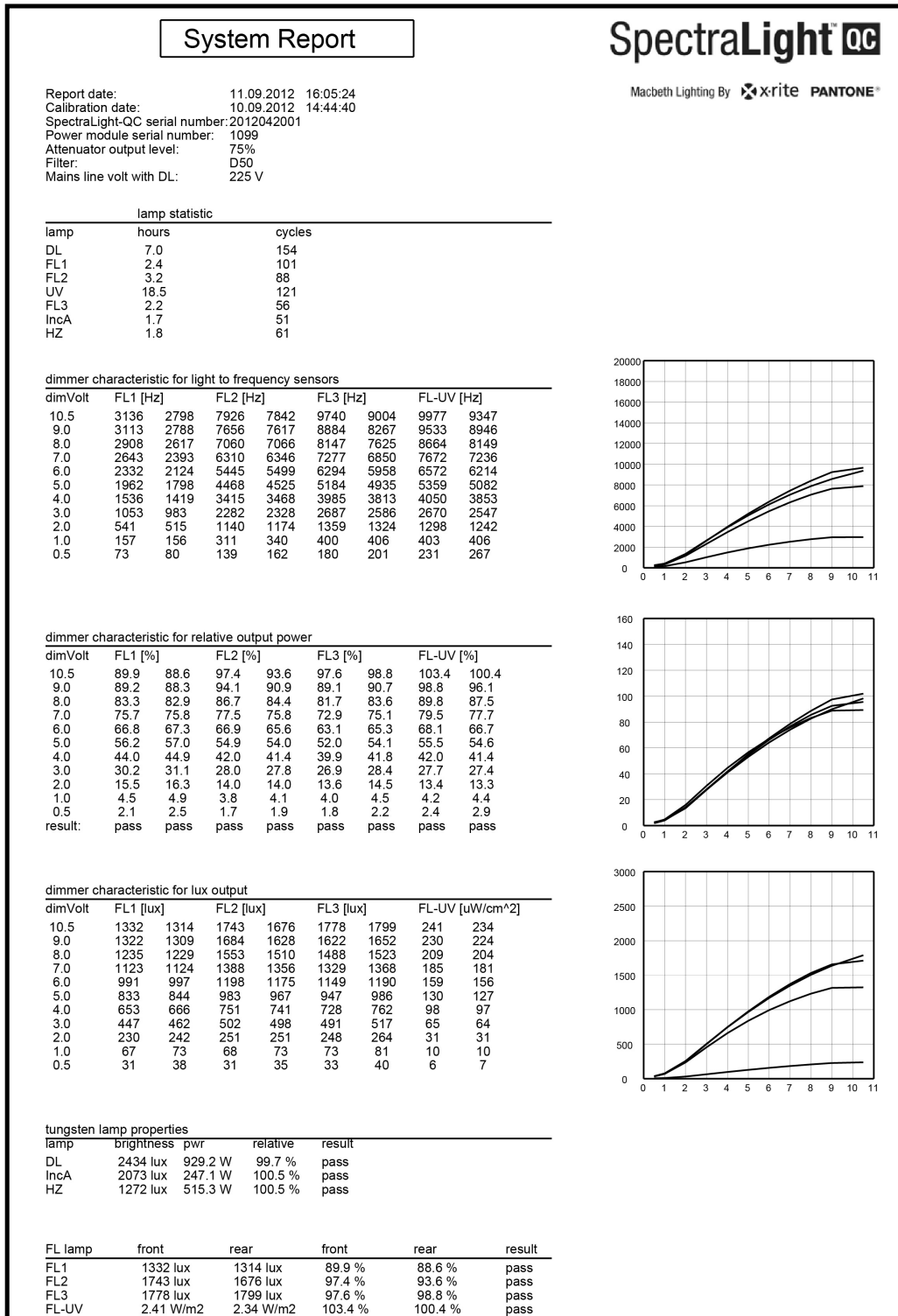

Sample Conformance Report

Conformance Report

SpectraLight Macbeth Lighting By  x-rite PANTONE®

Report date: 11. September 2012 16:06:36
 Calibration date: 10. September 2012
 SpectraLight-QC serial number: 2012042001
 SpectraLight-QC firmware ID: SPL IV 000.047J

Company information:

Company name:
 Department:
 Location:
 Brand:
 Remarks:

Operator information:

Alias name:
 FM100 score:
 Ishihara score:
 OptionalScore 1:
 OptionalScore 2:

Profile information:

Profile name: Factory
 free high norm low
 FL1 lux setting: 1250 1250 1250 1250
 FL2 lux setting: 1250 1250 1250 1250
 FL3 lux setting: 1250 1250 1250 1250

System settings:

Auto DL + UV: on
 Dim control: lux mode
 Lux mode: free lux mode

Daylight information:

Attenuator output level: 75%
 Filter: D50

Lamp codes

DL left Factory
 DL right Factory
 FL1 front Factory
 FL1 rear Factory
 FL2 front Factory
 FL2 rear Factory
 FL-UV front Factory
 FL-UV rear Factory
 FL3 front Factory
 FL3 rear Factory
 INC-A Factory
 HZ front1 Factory
 HZ front2 Factory
 HZ rear1 Factory
 HZ rear2 Factory

Lamp lifetime values

lamp	ix	ID	name	long name	op hours	eol hours	op cycles	eol cycles	status
DL	8	8	D50	DL 5000K	7.0	400	155	64000	OK
FL1	1	2	CWF	CWF	2.4	4000	102	10000	OK
FL2	2	3	TL84	TL84	3.2	4000	89	10000	OK
UV	3	4	UVA	UV A	18.5	4000	122	10000	OK
FL3	4	5	U30	U30	2.2	4000	57	10000	OK
IncA	5	6	A	INC A	1.7	400	52	64000	OK
HZ	6	7	HZ	HORIZON	1.8	400	62	64000	OK

REMOTE CONTROL OPERATION

The remote control (optional accessory) can be used to turn on light sources on the unit from a distance of 10 meters. If more than one remote is used with multiple units, the address code for the remote and the unit will need to be changed. Refer to the System Settings in the Configuration section for the procedure to change the address code. The default address code for the unit is set to “1”.

NOTE: Remote control must be specified at the time of purchase or installed by an Authorized Service Center.

Operation

Operation of the remote is similar to the switch operation on the unit. Press a source switch to turn it on and then press it again to turn the source off.



Remote Address Code Table

The address code that is set in the system setting configuration must be paired with the proper dipswitch settings on the remote for the remote to operate. The dipswitches are located on the back of the remote control under a cover.

The default address code for the system setting configuration is “1”. This setting requires dipswitch (A0) on the remote to be set to the “OFF” position, and dipswitches (A1-A9) on the remote to the “ON” position.

A total of “7” address codes can be used in the system setting configuration. Refer below for specific address code and dipswitch settings.

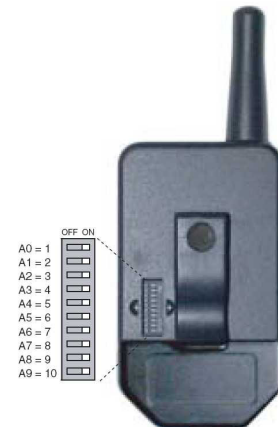

Address	A0	A1	A2	A3	A4	A5	A6	A7	A8	A9
1	off	on	on	on	on	on	on	on	on	on
2	on	on	on	on	off	on	on	on	on	on
3	off	on	on	on	off	on	on	on	on	on
4	on	on	on	on	on	on	on	on	off	on
5	off	on	on	on	on	on	on	on	off	on
6	on	on	on	on	off	on	on	on	off	on
7	off	on	on	on	off	on	on	on	off	on

OPTIONAL CONTROL BOX

The optional control box is used to operate up to eight banks (groups) of luminaires. The display on the control panel emulates the same controls as the luminaire for easy operation. Each group can simultaneously operate the group luminaires at one time.

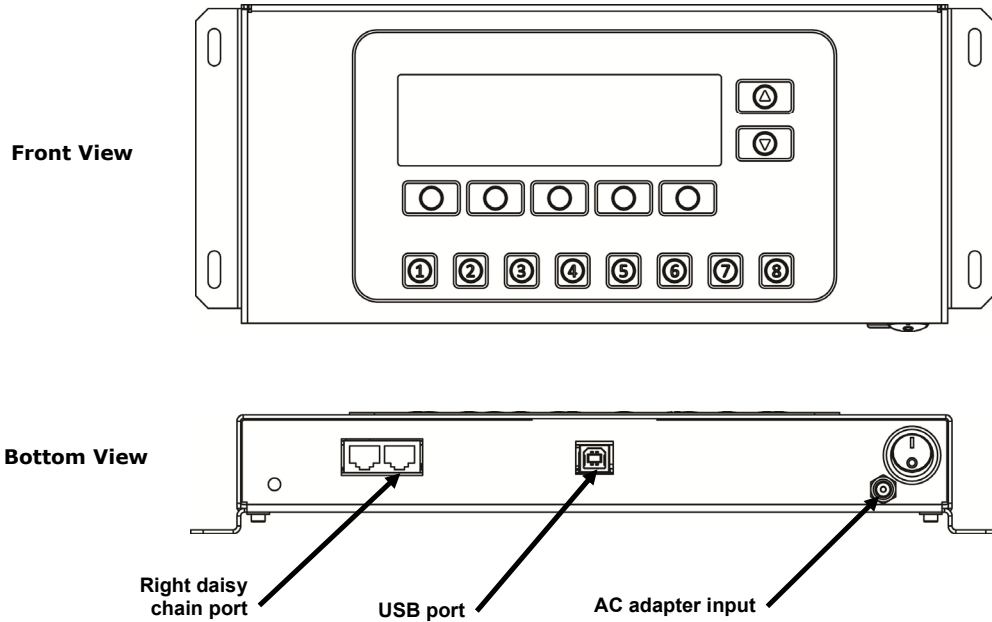

Installation

1. Mount the control box to a location where it will be used.
2. Connect one end of the daisy chain cable to the right port on the bottom of the control box.
3. Connect the other end of the cable to the left port under the front panel of the first luminaire.

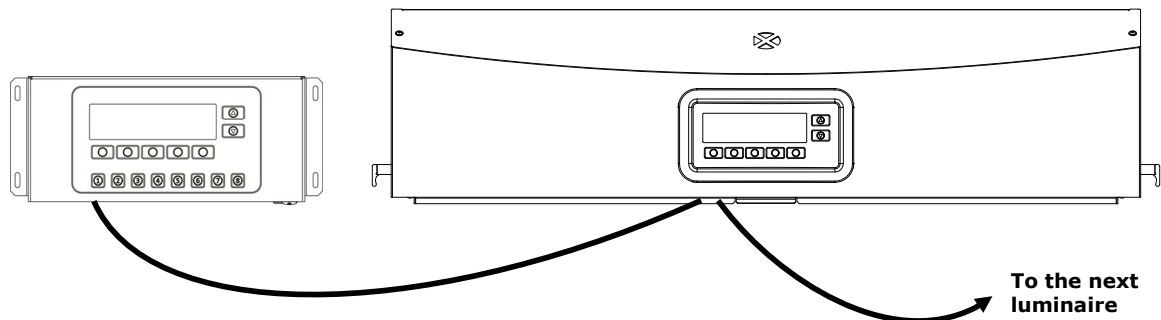

4. Continue connecting daisy chain cables to the remaining luminaires (left port in and right port out).
5. Attach the AC adapter to the control box and plug into an AC wall receptacle.
6. Connect the PC to the USB port on the control box to access and configure all of the individual luminaires.
7. Setup each luminaire with the required Group number and Device number. Refer to the Daisy Chain section earlier in this manual for setting up the luminaires.

APPENDICES

Service Information

SERVICE PROPERLY: With the exception of lamp replacement, do not attempt to service this product yourself. If you should attempt unauthorized repairs, you invalidate the warranty that is active on your unit. For any other malfunctions in operation, contact X-Rite Technical Service.

X-Rite provides repair service to their customers. All warranty and non-warranty repairs should be referred to an authorized service center. For non-warranty repairs, the customer shall pay shipping and repair cost to the authorized service center, and the instrument shall be submitted in the original carton, as a complete unaltered unit, along with all the supplied accessories. Refer to the Luminaire Repackaging procedure that follows for details.

X-Rite, Incorporated has offices around the world. You can contact us using one of the following methods:

- To identify the X-Rite service center nearest you, please visit our web site at: www.xrite.com and click the **Contact Us** link.
- For online help, visit our web site (www.xrite.com) and click the **Support** link. Here you can search for software or firmware updates, white papers, or frequently asked questions which can quickly resolve many common user problems.
- Send an e-mail to Customer Support: support@xrite.com detailing your problem and listing your contact information.
- For sales questions or to order cables and accessories, visit our web site (www.xrite.com) or contact your nearest X-Rite dealer or service center.
- Problems and questions can also be faxed to your local X-Rite office listed on our web site.

Luminaire Repackaging

Follow the steps below to ensure that the luminaire is properly repackaged before returning for repair.

1. Locate all of the original packaging materials.
2. Position the left, right, front, and back "L" shaped supports along the bottom edges inside the box.
3. Position the four "L" shaped supports vertically at each corner inside the box.
4. Place the bottom foam inserts on the left and right sides inside the box.

NOTE: Make sure the diffuser glass is removed before continuing with the next step.

5. Two people are required to lift and carefully position the luminaire into the bottom foam inserts.
6. Place the diffuser glass into its original carton and tape is it closed.
7. Insert the diffuser carton into the slots in the two upper foam pieces.
8. Position the two upper foam pieces with the diffuser on the left and right sides of the luminaire.
9. Insert the two remaining pieces of foam in the front and back of the luminaire.
10. Place the four remaining "L" shaped supports along the inside top edge of the box.
11. Place the large, flat piece of cardboard on top of the assembly and tape the box closed.

General Maintenance

Follow the procedures below for system cleaning, lamp replacements, and fuse replacement.

Cleaning (visible dust and dirt significantly reduce light output)

1. Turn off the main power switch and unplug AC line cord before proceeding with any maintenance procedure.



CAUTION: The daylight filters and tungsten halogen lamps get very hot during normal operation. Do not touch the filters or lamps; allow time for them to cool before cleaning.

Cleaning the Diffuser

1. Remove the front panel if the luminaire is installed on a booth.
2. Wash the exterior of the diffuser glass with water containing a mild detergent; rinse thoroughly, and air dry.



CAUTION: Make sure there are no objects in the way of the diffuser before opening.

3. Hold the diffuser and release the diffuser latch located at the front of the unit.
4. Slowly lower the front of the diffuser to its completely opened position (vertical).
5. Wash the interior of the diffuser glass with water containing a mild detergent; rinse thoroughly, and air dry.

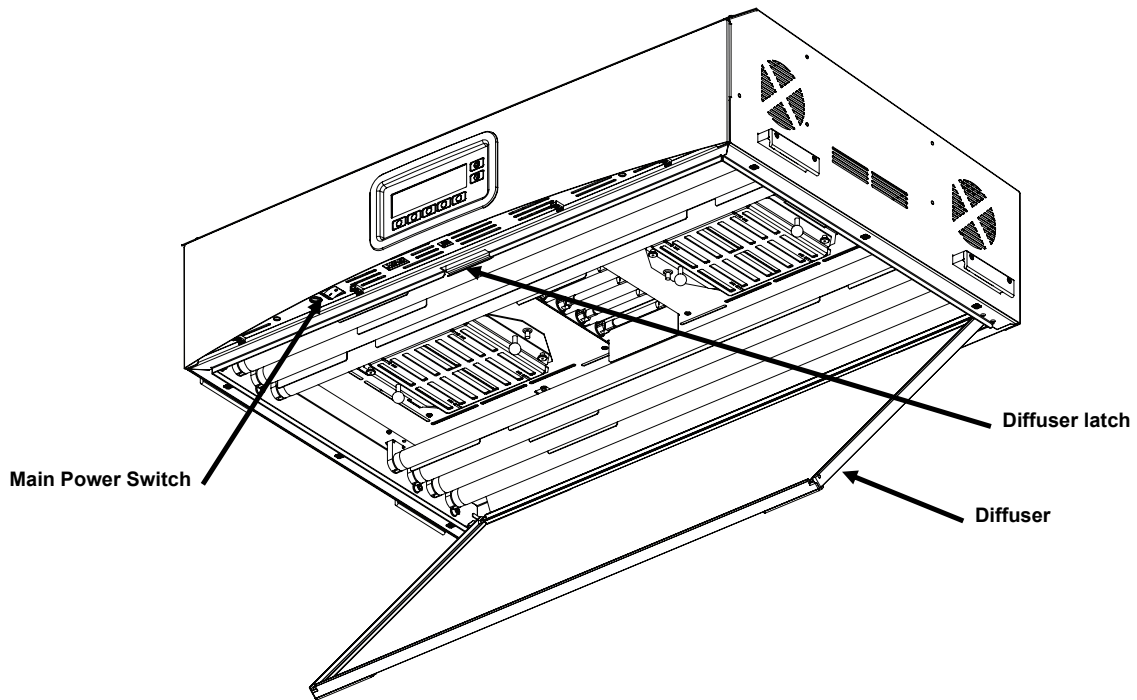

Figure 12. Luminaire with Diffuser Open

Cleaning the Daylight Filters

1. Unscrew the thumbscrews from the two daylight filters and carefully remove the attenuators.
2. Holding the filter pack, push in the fastener button and lower the daylight filter pack. Repeat the procedure for the other filter pack.

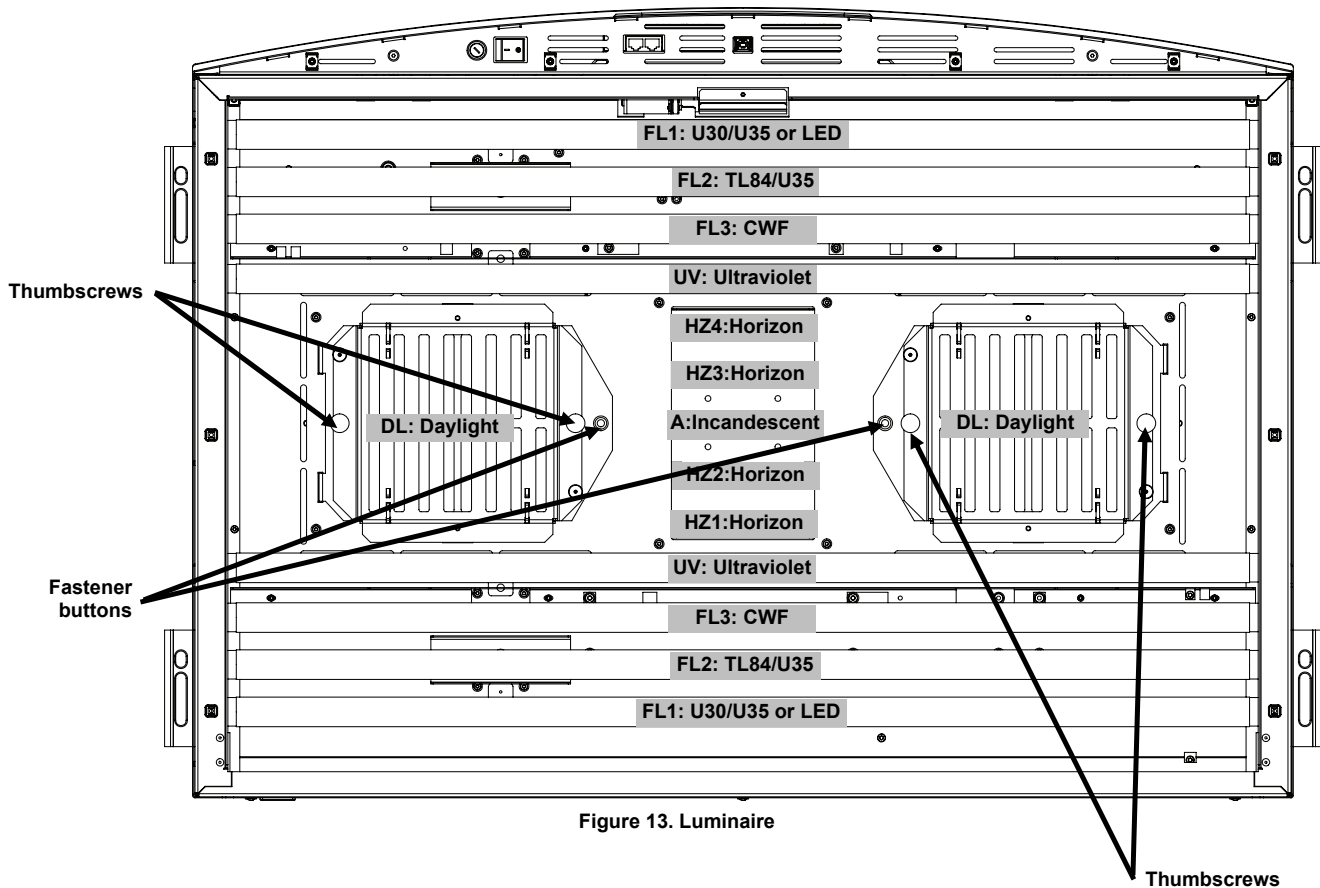

Figure 13. Luminaire

3. Remove dust from both sides with a clean, dry, lint-free cloth. Remove dirt and other foreign material from both sides with a spray-type window cleaner (AVOID EXCESSIVE MOISTURE). Air dry filter packs.
4. Remove dirt from the daylight lamp reflectors with a clean cloth dampened with warm water or a non-corrosive cleaner.

Note: Ensure the daylight filters are completely dry prior to operating the unit. Moisture may damage the filter when heated by the lamps.

5. Rotate the daylight filter pack back into position and push in on the fastener button to secure. Repeat procedure for other daylight filter pack.
6. Reinstall the attenuators on the filter packs with the thumb screws.

Cleaning the Fluorescent, LED and Halogen lamps

1. Remove dust from all remaining lamps with a clean, dry, lint-free cloth.
2. Remove dirt from all the remaining reflectors with a clean cloth dampened with warm water or an ammonia-based window cleaner. Air dry all components.

Closing the Diffuser

1. Rotate the diffuser to its closed position and secure it in place with the latch.
2. Plug in the AC power and turn on the power switch to begin normal operation.

Replacing the Lamps

Replace burned out lamps immediately in order to maintain the overall performance standards of the unit. We recommend replacing lamps in complete sets. For example, if one daylight lamp burns out, replace both of them.

Lamp Type	Rated Life (approx.)*	Lamp Type	Rated Life (approx.)*
Filtered Daylight (DL)	400 hours or after 65,000 switching cycles	U30 (FL1)	4,000 hours or after 10,000 switching cycles
Horizon (HZ)		U35 (FL1/FL2)	
Incandescent A (A)		TL84 (FL2)	
LED 3500K (FL1/FL2)	50,000 hours	Ultraviolet (UV)	2,000 hours or after 600 switching cycles
LED 4000K (FL1/FL2)		Cool White Fluorescent (FL3)	
LED 5000K (FL1/FL2)			

* Design and specifications subject to change without notice.

1. Turn off the main power switch and unplug AC line cord before proceeding.
2. For booth installations, remove the front panel.
3. Release the front diffuser latch. Lower the front of the diffuser to its opened position (vertical).



Allow time for the daylight filters or incandescent lamps to cool before handling them. Always use lens paper or equivalent when handling the lamps. Skin oils may reduce lamp lifetime.

Tungsten-Halogen Lamps

1. **Daylight Lamps Only:** Holding the filter pack, push in on the fastener button and lower the daylight filter pack. Repeat the procedure for the other filter pack.
2. Push one end of the old lamp into the spring loaded socket with pressure to release the other end from its socket.
3. Lift the lamp clear of both sockets and discard in an appropriate receptacle.
4. Using a piece of lens paper (or equivalent) between your fingers and the lamp; push one end of the replacement lamp into the socket. Refer to Figure 14.
5. Insert the other end of the lamp into the other socket and release the lamp. Refer to Figure 14.
6. Repeat step 2 through 5 for the other lamp.



Figure 14. Lamp Replacement

7. **Daylight Lamps Only:** Rotate the daylight filter pack back into position and push in on the fastener button to secure. Repeat procedure for other daylight filter pack.

Fluorescent and LED Lamps

1. Using both hands, rotate the lamp 1/4 turn and remove from both sockets.
2. Discard in an appropriate receptacle.
3. Install new fluorescent or LED lamp into the sockets.
4. Repeat steps 1 through 3 for the other lamp.

Closing the Diffuser

1. Rotate the diffuser to its closed position and secure it in place with the latch.
2. Plug in the AC power and turn on the power switch to begin normal operation.
3. Reset the lamp hours using the RLAMP procedure in the User Settings section.

Replacing the Fuse

1. Turn off the main power switch and unplug AC line cord before proceeding.
2. Using a flat blade screwdriver, push in on fuse holder and rotate counterclockwise 1/4 turn.

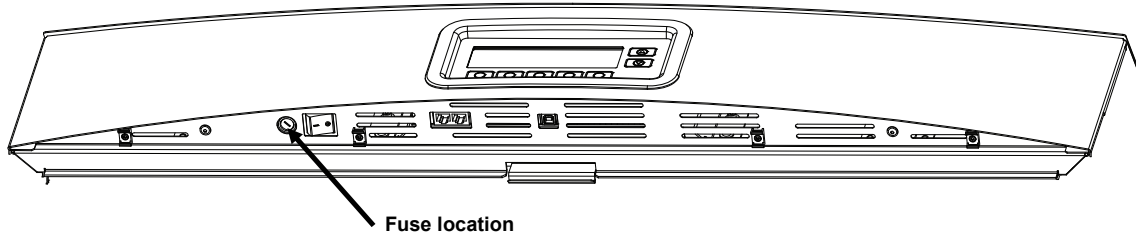

3. Remove fuse holder and discard blown fuse.
4. Refer to the following chart for fuse requirements.

AC Requirements	Fuse Type
115 VAC	F 10 A H 250 V (5x20 mm)
230 VAC	F 6.3 A H 250 V (5x20 mm)
100 VAC	F 15 A H 250 V (5x20 mm)

5. Insert new fuse into the holder and then insert into the unit.
6. Using a flat blade screwdriver, push in on holder and rotate 1/4 turn clockwise until secure.
7. Plug in the AC power and turn on the power switch to begin normal operation.

Screen Messages

Screen messages can appear on the display during error conditions or for informational purposes. Some messages require user interaction to clear while others only appear momentarily and require no action. If an error message persists, please contact our technical support using one of the methods listed in the Service Information section.

User action message example



Momentary message example



Switch descriptions

- HELP:** Provides additional information on the message to help diagnose the problem.
- REMOU:** Keeps the message from appearing in the future.
- OK:** Clears the message from the screen.

Troubleshooting

Prior to contacting X-Rite support department for system problems, try the applicable solution(s) described below. If the condition persists, contact us using one of the methods listed in the Service Information section.

Problem	Cause/Solution
Unit not responding	Unit is in low power mode. Press a switch on the front display panel.
	Switch the main power switch off for 5 seconds then switch back to the ON position.
	Unit is unplugged. Make sure the AC plug is connected.
	A fuse is blown. See Appendix for fuse replacement procedure.
	Contact X-Rite technical support.
Lamp not working	Lamp burned out or not installed properly. Refer to the Maintenance section for lamp replacement procedure.
	Contact X-Rite technical support.
	NOTE: For fluorescent lamps, we guarantee a minimum of at least 1250 lux. However, due to the significant variation in commercial tubes, the lux may be significantly higher.
Remote control not working	Battery in remote is bad. Replace the battery.
	Wrong address code assigned to luminaire. Refer to System Setting in the Configuration section to check address code.
	Dipswitch settings on remote not correct. Refer to Remote Control Operation section earlier in the manual for information on dipswitch settings.
	Contact X-Rite technical support.
Daisy chained luminaires not working	Coupling cables are not connected properly. Check all cables and verify connections.
	Daisy chain setting settings are incorrect. Refer to Daisy Chain Setting in the Configuration section to verify proper settings.
	Restart the master control (first device or control box).
	Contact X-Rite technical support.

Specifications

	OVERHEAD LUMINAIRE	VIEWING BOOTH
DIMENSIONS	D 685 x H 250 x W 945 mm (D 27 x H 9.84 x W 37.20 in)	D 610 x H 700 x W 945 mm (D 24.01 x H 27.55 x W 37.20 in)
WEIGHT/SHIPPING WEIGHT	40.5 kg (89.3 lbs)/ 53.0 kg (116.8 lbs)	10.0 kg (22.0 lbs)/ 16.0 kg (35.2 lbs)
ELECTRICAL	<p>Power L1NPE, 115Vac, 50/60Hz, 1150W L1NPE, 230Vac, 50/60Hz, 1150W L1NPE, 100Vac, 50/60Hz, 1150W</p> <p>Main Fuse 115 VAC: F 10 A H 250 V (5x20 mm) 230 VAC: F 6.3 A H 250 V (5x20 mm) 100 VAC: F 15 A H 250 V (5x20 mm)</p> <p>Power Cord Connector: country specific Plug: IEC 60320 C13 type</p> <p>Standby Power 2 W</p>	
OPTICS	<p>Lamps DL – Daylight: Two (2) FDF, 500W, 120V A – Incandescent A: One (1) EHM, 300W, 120V HZ – Horizon: Four (4) FDF, 500W, 120V FL1 – U30: Two (2) FO25/830/XP/ECO3 or U35: Two (2) F25T8/SPX35/ECO FL2 – TL84: Two (2) TLD 30W/840 SUPER or U35: Two (2) F25T8/SPX35/ECO FL3 – CWF: Two (2) F30T8/CW UV – UltraViolet: Two (2) F30T8BLB FL1 – LED: 4000 K, Two (2) LED11ET8/G/3/940 FL1 – LED: 5000 K, Two (2) LED11ET8/G/3/950</p> <p>Daylight Filter Options D50 filter: 5000 K, qty 8 D65 filter: 6500 K, qty 8</p> <p>Daylight Attenuator Options 25% Attenuator 50% Attenuator 75% Attenuator</p>	
SAFETY COMPLIANCE	<p>Pollution Degree: 2 Usage: UL Listed, Indoor Only Altitude: 2000M Transient Overvoltage: Category II</p>	
ENVIRONMENTAL REQUIREMENTS	<p>Operating Temperature: 0°C to 35°C (32°F to 95°F) Storage Temperature: -40°C to 70°C (-40°F to 158°F) Relative Humidity: 0 to 95% max (non condensing)</p>	

Design and specifications subject to change without notice.

Menu Screen Flowchart

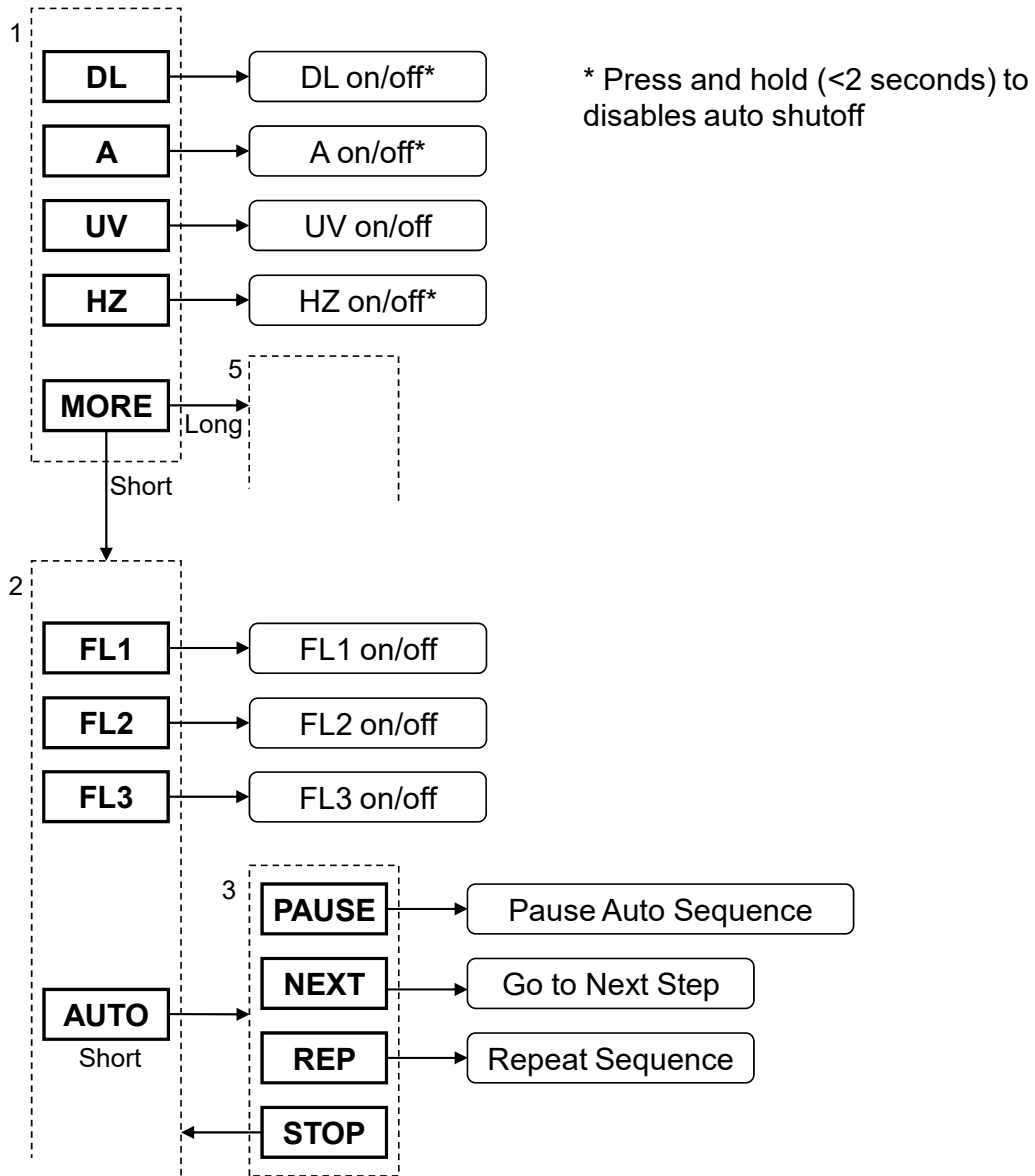

Continued...

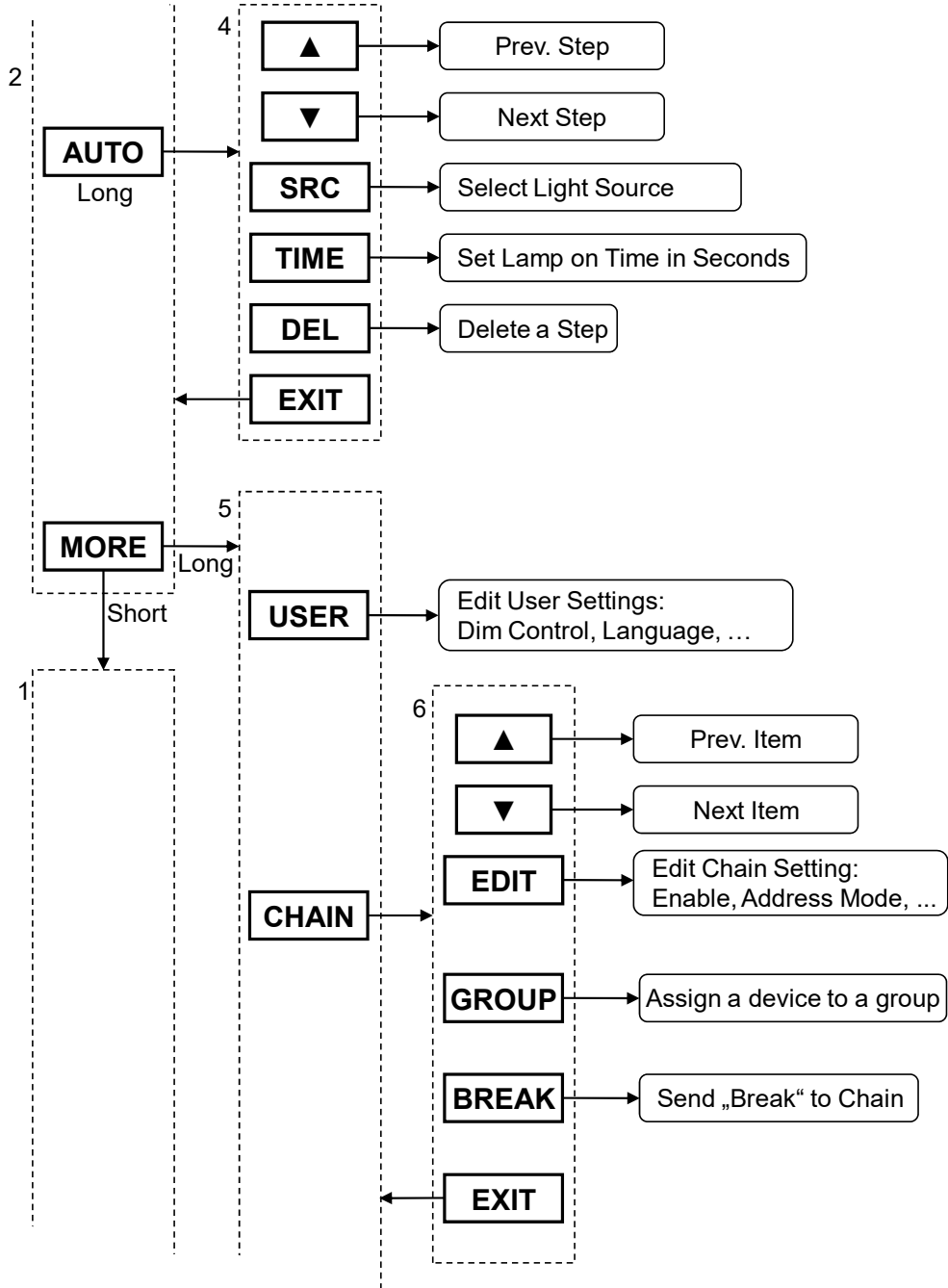

Continued...

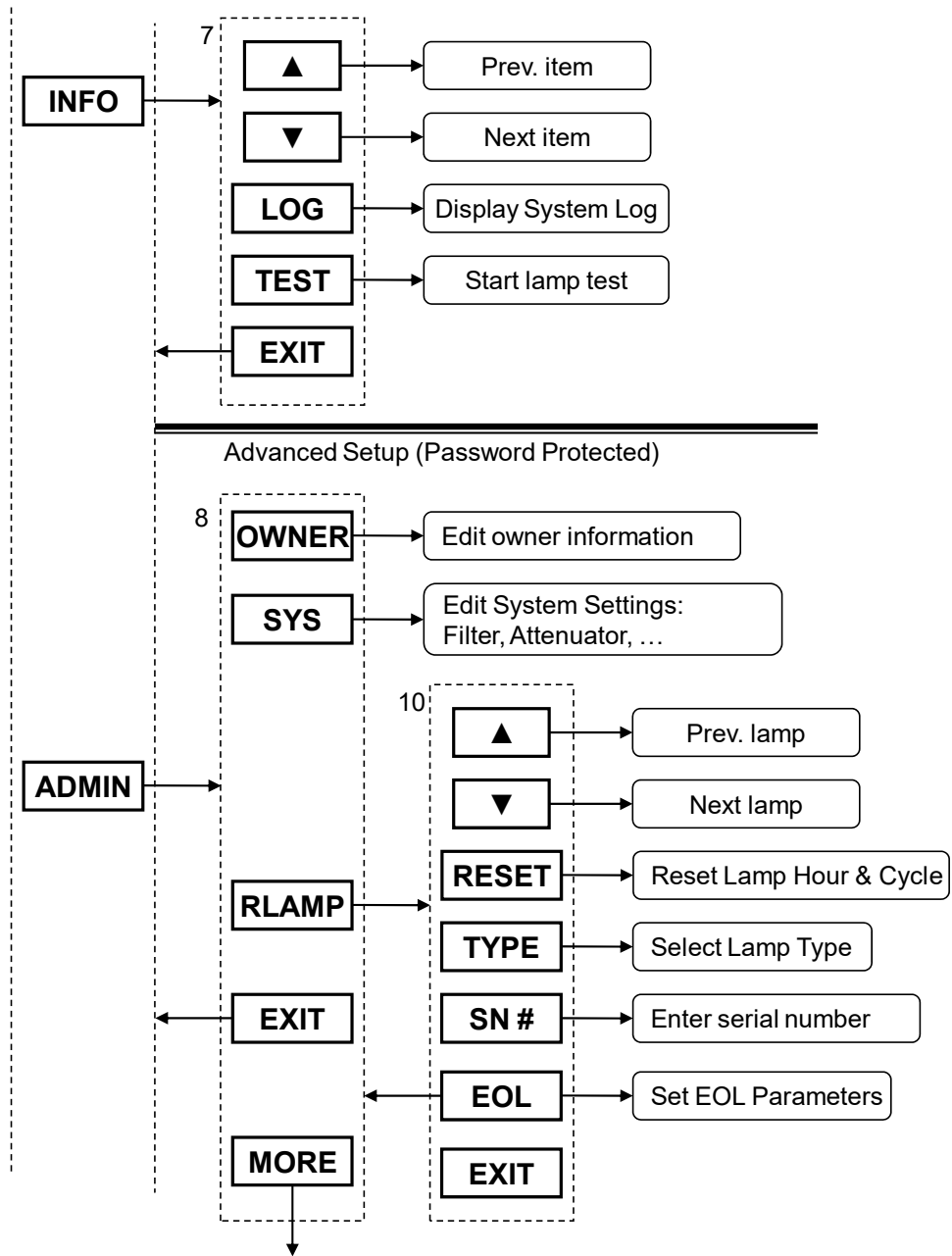

Continued...

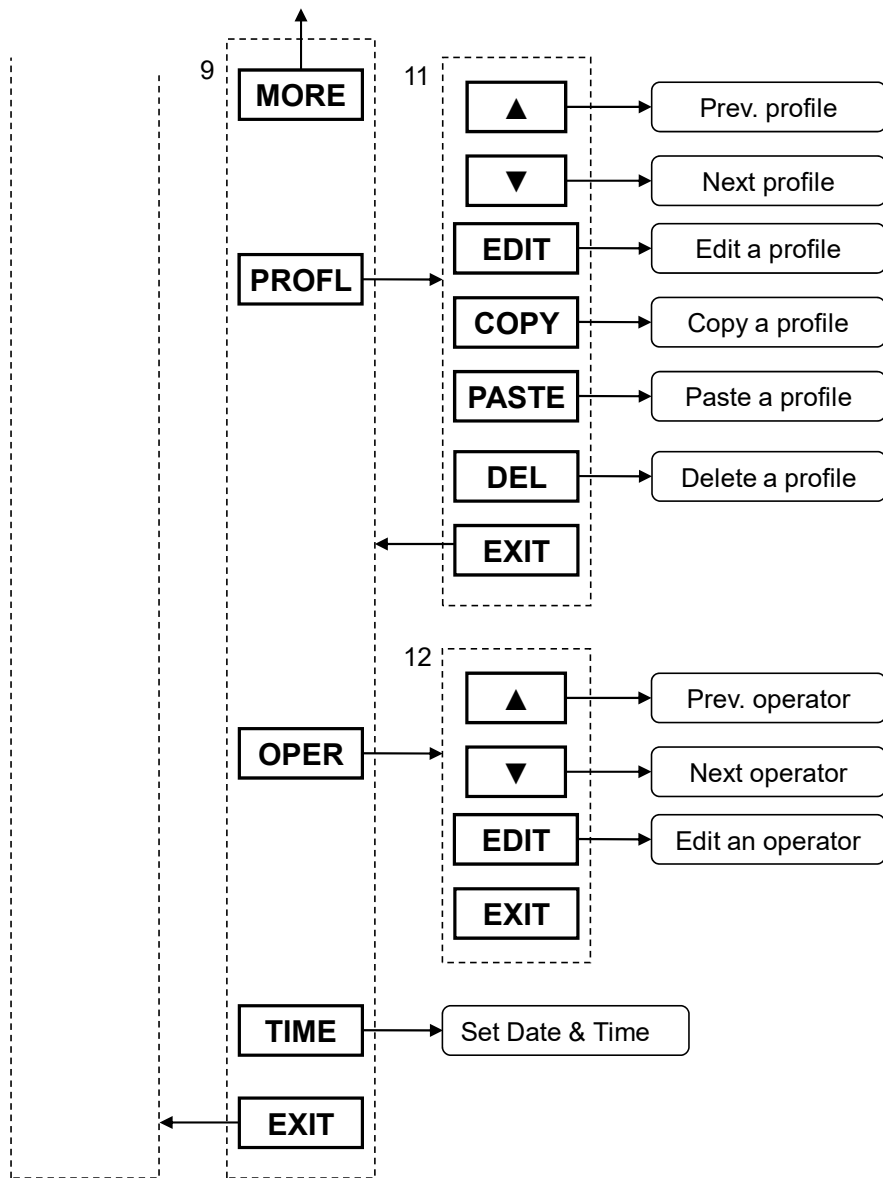

Parts and Accessories

Consult your X-Rite Price List for additional Lamp Kit Options or call your local X-Rite office. Refer to the back page of the document for contact information.

Replacement Lamps

Part Number	Lamp Qty	Description
SPQ-L/DH2	2	Daylight & Horizon, 500 watt tungsten halogen lamps
SPQ-L/DH4	4	Daylight & Horizon, 500 watt tungsten halogen lamps
SPQ-L/A1	1	Incandescent A - 300 watt tungsten halogen lamp
SPQ-L/CWF2	2	Cool White Fluorescent 4200K (CWF or F2) 36" T8 lamps
SPQ-L/U302	2	Ultralume 3000K (U30, TL83 or F12) 36" T8 lamps
A-L/SPLU30-8	8	Ultralume 3000K (U30, TL83 or F12) 36" T8 lamps
SPQ-L/U352	2	Ultralume 3500K (U35) 36" T8 lamps
A-L/SPLU35-8	8	Ultralume 3500K (U35) 36" T8 lamps
SPQ-L/TL842	2	Ultralume 4000K (U40, TL84 or F11) 36" T8 lamps
SPLQ-L/UVCE2	2	Black light blue 368nm UV-A, 36" T8 lamps
SPQ-LK/3035CWF	Kit	Full Lamp Replacement Kit - U30/U35
SPQ-LK/3084CWF	Kit	Full Lamp Replacement Kit - U30/TL84
SPQ-LK/3584CWF	Kit	Full Lamp Replacement Kit - U35/TL84
SPQ-L/LED4WM	2	LED 4000K 36" T8 lamps
SPQ-L/LED950	2	LED 5000K 36" T8 lamps

*Please inquire for larger case quantities.

Optional Accessories

Part Number	Description
SPQUSB	USB Cable
SPQDC	Daisy Chain Cable
SPQCBNR	Control Box Kit w/remote
SPQCBS	Control Box Kit w/o remote
SPQBN7	Viewing Booth, Munsell N7
SPQDG	Diffuser Glass



Corporate Headquarters

X-Rite, Incorporated
4300 44th Street SE
Grand Rapids, Michigan 49512
Phone 1 800 248 9748 or 1 616 803 2100
Fax 1 800 292 4437 or 1 616 803 2705

European Headquarters

X-Rite Europe GmbH
Althardstrasse 70
8105 Regensdorf
Switzerland
Phone (+41) 44 842 24 00
Fax (+41) 44 842 22 22

Asia Pacific Headquarters

X-Rite Asia Pacific Limited
Suite 2801, 28th Floor, AXA Tower
Landmark East, 100 How Ming Street
Kwun Tong, Kowloon, Hong Kong
Phone (852) 2568-6283
Fax (852) 2885 8610

Please visit www.xrite.com for a local office near you.