





*Dear Customer:*

*Congratulations on your purchase of an X-Rite SP60 Series Spectrophotometer. This instrument represents the very latest in microcontrollers, integrated circuits, optics, and display technology. As a result, your X-Rite instrument is a rugged and reliable instrument whose performance and design exhibit the qualities of a finely engineered instrument, which is not surpassed.*

*To fully appreciate and protect your investment, we suggest that you take the necessary time to read and fully understand this manual. As always, X-Rite stands behind your instrument with a one-year limited warranty, and a dedicated service organization. If the need arises, please don't hesitate to call us.*

*Thank you for your trust and confidence.*

*X-Rite, Incorporated*

## Federal Communications Commission Notice

This equipment has been tested and found to comply with the limits for a Class A digital device, pursuant to Part 15 of the FCC Rules. These limits are designed to provide reasonable protection against harmful interference when the equipment is operated in a commercial environment. This equipment generates, uses, and can radiate radio frequency energy and, if not installed and used in accordance with the instruction manual, may cause harmful interference to radio communications. Operation of this equipment in a residential area is likely to cause harmful interference in which case the user will be required to correct the interference at his own expense.

## Industry Canada Compliance Statement

This digital apparatus does not exceed the Class A limits for radio noise emissions from digital apparatus set out in the Radio Interference Regulations of the Canadian Department of Communications.

Le présent appareil numérique n'émet pas de bruits radioélectriques dépassant les limites applicables aux appareils numériques de la class A prescrites dans le Règlement sur le brouillage radioélectrique édicté par le ministère des Communications du Canada.

---

**ACHTUNG:** Um das Produkt innerhalb der FCC (Vereinigten Staaten) und den europäischen Emissions-Richtlinien zu halten, müssen geschirmte Schnittstellenkabel verwendet werden.

**AVISO:** Para satisfacer las deseadas regulaciones de emisión para Europa y el FCC, se debe utilizar los cables de interfaz protegidos contra las interferencias electromagnéticas.

**AVERTISSEMENT:** Des câbles d'interface blindés doivent être utilisés afin de se conformer aux règlements d'émission européens et de FCC (Etats-Unis).

**AVVISO:** Per conformare con i desiderati regolamentazioni di emissione per Europa ed il FCC, utilizzare i cavi d'interfaccia protetti contro l'interferenze elettromagnetiche.

---

**WARNING:** This instrument is not for use in explosive environment.

**WARNUNG:** Das Gerät darf in einer explosiven Umgebung NICHT verwendet werden.

**ADVERTENCIA** - NO use este aparato en los ambientes explosivos.

**ATTENTION:** Cet instrument NE DOIT PAS être utilisé dans un environnement explosif.

**AVVERTIMENTO** - NON usare questo apparecchio in ambienti esplosivi.

---

**CAUTION:** Operational hazard exists if battery charger other than SE30-177 (100-240V) is used. Use only X-Rite battery pack SP62-79-33, other types may burst causing personal injury.

**VORSICHT:** Betriebs- und Verletzungsgefahr besteht bei Gebrauch von anderen Adaptern als X-Rite SE30-177 (100-240 V). Verwenden Sie nur den X-Rite Akkupack SP62-79-33.

**ADVERTENCIA:** No use otro cargador de las pilas que no sea la pieza X-Rite SE30-177 (100-240V), para evitar el riesgo de mal funcionamiento del equipo. Use solamente las pilas SP62-79-33 de X-Rite, es posible que los otros tipos puedan estallar y causar daños corporales.

**ATTENTION:** Pour ne pas causer un mauvais fonctionnement de l'appareil, veuillez à utiliser uniquement les chargeurs de batterie X-Rite SE30-177 (100-240 V). Veuillez aussi à utiliser uniquement la batterie X-Rite SP62-79-33, d'autres batteries pouvant exploser et causer des blessures.

**AVVERTENZA:** Non usare un altro caricabatterie che non è del pezzo X-Rite SE30-177 (100-240V), per evitare il rischio di malfunzionamento dell'apparecchio. Usare solamente gli accumulatori SP62-79-33 di X-Rite, è possibile che altri tipi possano scoppiare e causare danno personale.

---

The Manufacturer:	X-Rite, Incorporated
Der Hersteller:	4300 44th Street, S.W.
El fabricante:	Grand Rapids, Michigan 49512
Le fabricant:	
Il fabbricante:	
Declares that:	Spectrophotometer
gibt bekannt daß:	SP60 Series
advertit que:	
avertit que:	
avverte che:	



is not intended to be connected to a public telecommunications network.  
nicht an ein öffentliches Telekommunikations-Netzwerk angeschlossen werden soll.  
no debe ser conectado a redes de telecomunicaciones públicas.  
ne doit pas être relié à un réseau de télécommunications publique.  
non deve essere connesso a reti di telecomunicazioni pubblici.

---

## **CE DECLARATION**

**CE** Hereby, X-Rite, Incorporated, declares that this SP60 Series is in compliance with the essential requirements and other relevant provisions of Directive(s) EMC 2004/108/EC, LVD 2006/95/EC, and RoHS 2011/65/EU (Category 9).



Instructions for disposal: Please dispose of Waste Electrical and Electronic Equipment (WEEE) at designated collection points for the recycling of such equipment.

# Table of Contents

Proprietary Notice	viii
Warranty Information	viii
<b>Section 1 – Overview and Setup</b>	
Instrument Description	1-1
Features	1-2
Unpacking and Inspection	1-2
Installing the Battery Pack	1-3
Changing the Aperture Setting (SP64 only)	1-3
Applying Power	1-4
Charging the Battery Pack	1-5
Unlatching the Instrument Shoe	1-6
Instrument I/O Serial Interface	1-7
Attaching the Wrist Strap	1-7
<b>Section 2 – User Interface</b>	
What to Expect	2-1
Navigation – Basic Key Operation	2-1
Tab Down Key	2-2
Tab Up Key	2-2
Enter Key	2-2
Escape Key	2-2
Main Menu Key	2-2
Read Key	2-2
Measurement Mode Screens	2-3
Data Storage Information	2-3
Color Data Parameters	2-3
Color Data	2-3
Using the Instrument	2-4
Opening a Menu or Mode	2-4
Opening a Pop-Up List Box	2-4
Opening the Alphanumeric Editor	2-5
Selecting Single or Multiple Items	2-5
Selecting Color Data Parameters	2-6
Instrument Indicator Light	2-6
Important Measurement Techniques	2-6
<b>Section 3 – Calibrating the Instrument</b>	
General Information	3-1
Positioning the Instrument on the Reference	3-2
Calibration Procedure	3-3
<b>Section 4 – Setting Instrument Configuration</b>	
General Information	4-1
Language	4-1
Measure Options	4-2

Store Samples	4-3
Pass/Fail	4-3
Auto Std	4-3
Averaging	4-3
Diff Disp	4-4
Color Options	4-5
Active Functions	4-6
Active Illum/Obs	4-6
Opacity	4-7
Strength	4-8
Metamerism	4-8
$\Delta$ Ecmc Factors	4-9
$\Delta$ E94 Factors	4-10
Shade Sort	4-10
SP88 SPEX Mode	4-11
Database Tools	4-11
Factory Presets	4-12
Clear Database	4-12
Clear All Samples	4-13
Clear All Tags	4-13
Clear All Projects	4-13
Clear All Jobs	4-14
Clear All Standards	4-14
Hardware Setup	4-15
Serial Port	4-17
Read Operation	4-19
Cal Timeout	4-19
Power Down	4-20
Beeper	4-20
Clock Adjust	4-21
Display	4-22
Load Factory Defaults	4-24

## **Section 5 – Instrument Operations**

Standards Mode	5-1
Selecting Standard Number	5-1
Entering Standard Data	5-2
Entering Standard Name	5-4
Setting Tolerance Limits	5-5
Setting Shade Sort Options	5-7
Locking/Unlocking the Standard	5-9
Deleting the Standard	5-10
Project Mode	5-11
Selecting Project Number	5-11
Assigning Standards to a Project	5-12
Entering a Project Name	5-13
Locking/Unlocking the Project	5-14
Add New Project	5-14
Deleting the Project	5-14

QA Mode	5-15
Selecting a Project	5-16
Selecting a Standard	5-16
Pass/Fail Operation	5-17
555 Shade Sort Operation	5-17
Display Difference Indication	5-18
Storage Operation	5-19
Measurement Averaging	5-19
Sample Database Tools	5-20
Viewing the Reflectance Graph	5-21
Strength Mode	5-23
Strength Measurement	5-24
Opacity Mode	5-25
Opacity Measurement	5-26
Analyze Mode	5-27
Compare Mode	5-28
Run Job Mode (SP64 only)	5-29
<b>Section 6 – Service and General Maintenance</b>	
Repair Information	6-1
Reading Lamp Replacement Information	6-1
Cleaning the Instrument	6-1
General Cleaning	6-1
Cleaning the Optics	6-2
Cleaning the Calibration Reference	6-2
Replacing the Battery Pack	6-3
<b>Appendices</b>	
Instrument Specification	7-1
Error Messages	7-3



## Proprietary Notice

The information contained in this manual is derived from patent and proprietary data of X-Rite, Incorporated. This manual has been prepared solely for the purpose of assisting in the use and general maintenance of this instrument.

The contents of this manual are the property of X-Rite, Incorporated and are copyrighted. Any reproduction in whole or part is strictly prohibited.

Publication of this information does not imply any rights to reproduce or use this manual for any purpose other than installing, operating, or maintaining this instrument. No part of this manual may be reproduced, transcribed, transmitted, stored in a retrieval system, or translated into any language or computer language, in any form or by any means, electronic, magnetic, mechanical, optical, manual, or otherwise, without the prior written permission of an officer of X-Rite, Incorporated.

This instrument may be covered by one or more patents. Refer to the instrument for actual patent numbers.

Copyright © 2013 by X-Rite, Incorporated

“ALL RIGHTS RESERVED”

X-Rite® is a registered trademark of X-Rite, Incorporated. All other logos, brand names, and product names mentioned are the properties of their respective holders.

## Warranty Information

X-Rite, Incorporated (“X-Rite”) warrants each instrument manufactured to be free of defects in material and workmanship for a period of 12 months\*. This warranty shall be fulfilled by the repair or replacement, at the option of X-Rite, of any part or parts, free of charge including labor, F.O.B. its factory or authorized service center.

X-Rite warrants this Product against defects in material and workmanship for a period of twelve (12) months from the date of shipment from X-Rite’s facility, unless mandatory law provides for longer periods. During such time, X-Rite will either replace or repair at its discretion defective parts free of charge.

X-Rite’s warranties herein do not cover failure of warranted goods resulting from: (i) damage after shipment, accident, abuse, misuse, neglect, alteration or any other use not in accordance with X-Rite’s recommendations, accompanying documentation, published specifications, and standard industry practice; (ii) using the device in an operating environment outside the recommended specifications or failure to follow the maintenance procedures in X-Rite’s accompanying documentation or published specifications; (iii) repair or service by anyone other than X-Rite or its authorized representatives; (iv) the failure of the warranted goods caused by use of any parts or consumables not manufactured, distributed, or approved by X-Rite; (v) any attachments or modifications to the warranted goods that are not manufactured, distributed or approved by X-Rite. Consumable parts and Product cleaning are also not covered by the warranty.

X-Rite’s sole and exclusive obligation for breach of the above warranties shall be the repair or replacement of any part, without charge, which within the warranty period is

proven to X-Rite's reasonable satisfaction to have been defective. Repairs or replacement by X-Rite shall not revive an otherwise expired warranty, nor shall the same extend the duration of a warranty.

Customer shall be responsible for packaging and shipping the defective product to the service center designated by X-Rite. X-Rite shall pay for the return of the product to Customer if the shipment is to a location within the region in which the X-Rite service center is located. Customer shall be responsible for paying all shipping charges, duties, taxes, and any other charges for products returned to any other locations. Proof of purchase in the form of a bill of sale or receipted invoice which is evidence that the unit is within the Warranty period must be presented to obtain warranty service. Do not try to dismantle the Product. Unauthorized dismantling of the equipment will void all warranty claims. Contact the X-Rite Support or the nearest X-Rite Service Center, if you believe that the unit does not work anymore or does not work correctly.

THESE WARRANTIES ARE GIVEN SOLELY TO BUYER AND ARE IN LIEU OF ALL OTHER WARRANTIES, EXPRESSED OR IMPLIED, INCLUDING BUT NOT LIMITED TO THE IMPLIED WARRANTIES OF MERCHANTABILITY, FITNESS FOR A PARTICULAR PURPOSE OR APPLICATION, AND NON-INFRINGEMENT. NO EMPLOYEE OR AGENT OF X-RITE, OTHER THAN AN OFFICER OF X-RITE, IS AUTHORIZED TO MAKE ANY WARRANTY IN ADDITION TO THE FOREGOING.

IN NO EVENT WILL X-RITE BE LIABLE FOR ANY OF BUYER'S MANUFACTURING COSTS, OVERHEAD, LOST PROFITS, GOODWILL, OTHER EXPENSES OR ANY INDIRECT, SPECIAL, INCIDENTAL OR CONSEQUENTIAL DAMAGES BASED UPON BREACH OF ANY WARRANTY, BREACH OF CONTRACT, NEGLIGENCE, STRICT TORT, OR ANY OTHER LEGAL THEORY. IN ANY EVENT OF LIABILITY, X-RITE'S MAXIMUM LIABILITY HEREUNDER WILL NOT EXCEED THE PRICE OF THE GOODS OR SERVICES FURNISHED BY X-RITE GIVING RISE TO THE CLAIM.



# Overview and Setup

Instrument Description	1-1
Features	1-2
Unpacking and Inspection	1-2
Installing the Battery Pack	1-3
Changing the Aperture Setting	1-3
Applying Power	1-4
Charging Battery Pack	1-5
Unlatching the Instrument Shoe	1-6
Instrument I/O Serial Interface	1-7
Attaching the Wrist Strap	1-7

## Instrument Description

The X-Rite SP60 Series Spectrophotometer’s compact spectral engine utilizes X-Rite’s DRS (Dynamic Rotational Sampling) technology, allowing accurate and precise measurements. This instrument has intuitive keys and a high-contrast graphic display. To determine the influence of the specular component, the instrument automatically provides both specular-included and specular-excluded data.

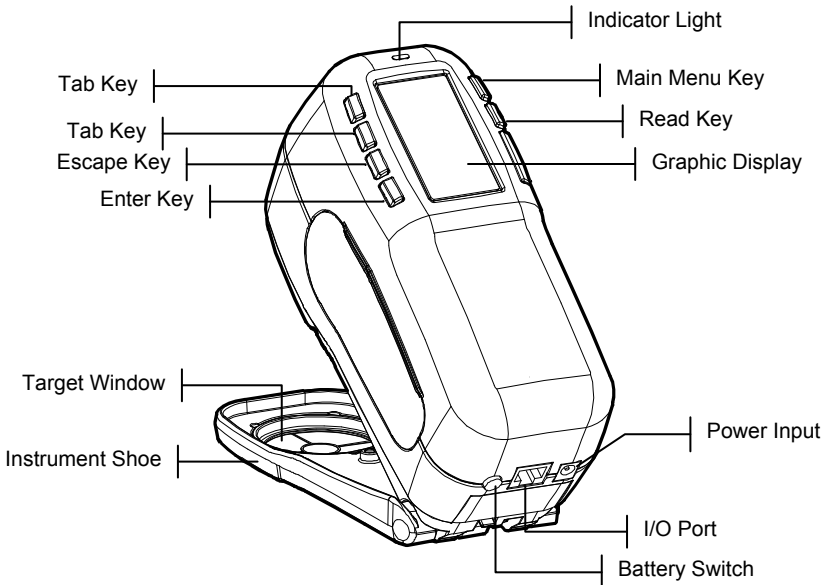

## Features

### **Automatic Shut-Off**

To increase battery life, the instrument automatically turns itself off if it is not used within a user-defined time—between 10 and 240 seconds. *See Setting Instrument Configuration, Section Four for more information.* The instrument turns back on whenever a key is pressed, a measurement is taken, or the adapter is plugged in.

### **Graphic Display**

A high contrast, 128 x 64 pixel graphics display provides a versatile means of displaying the measured data.

### **Indicator Light**

A multi-color LED at the top of the instrument provides visual feedback on the status of measurements.

### **Quick Color Compare**

An operator can take a quick measurement and comparison of two colors. This allows the instrument to be used for taking quality control readings in a time-efficient manner without the necessity of creating tolerances.

## Unpack and Inspect

After removing the instrument from the shipping carton, inspect it for damage. If any damage has occurred during shipping, immediately contact the transportation company. Do not proceed with installation until the carrier's agent has inspected the damage.

Your instrument was packaged in a specially designed carton to assure against damage. If shipment is necessary, the instrument should be packaged in the original carton. If the original carton is not available, contact X-Rite to have a replacement carton shipped to you.

## Install the Battery Pack

The instrument is shipped from the factory with the battery pack removed. The battery pack is located in a carrying case compartment and must be installed before the instrument is used.

1. Hold the shoe next to the instrument housing and lift upward on the spring-loaded latch (*refer to Unlatching the Instrument Shoe*). Open the shoe perpendicular to the instrument housing.
2. Carefully rotate the instrument over and rest it on its top.
3. Slide the battery pack into the compartment with the battery connector facing down and to the back of the instrument.
4. Press down on the pack until the connector is properly seated and the tabs click into position.

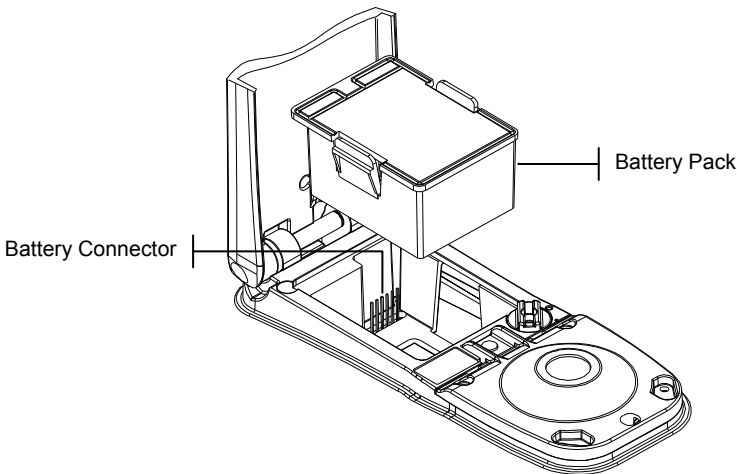

## Changing the Aperture Setting (SP64 only)

The standard SP64 can take measurements using either a 4mm aperture or 8mm aperture. Simply rotating the aperture knob and switching target windows changes the setting.

■ **NOTE:** The large spot SP64 instrument (14mm) does not have an aperture changing knob.

**To change the Aperture Setting and Target Window:**

1. Turn the instrument over and rotate the knob to the left for 8mm (large circle indication) setting and to the right for 4mm (small circle indication) setting. The instrument's display informs you of the aperture change. Press the Enter key  $\leftarrow$  to accept the change.

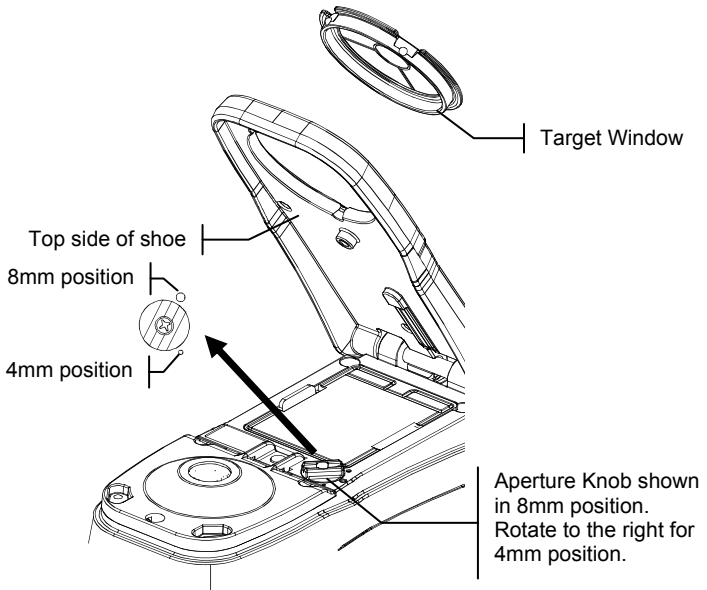

2. Using your fingers, press the target window out from the top side of the shoe. Press against the ring and not the clear window.
3. Note the alignment of the new window and snap it into place from the bottom side of the shoe.
4. Calibrate the instrument to the new aperture setting.

**NOTE:** The instrument only needs to be calibrated once for each aperture setting. Thereafter, the instrument does not require calibration when switching between aperture settings, until the calibration time expires.

**Apply Power**

The Battery switch—located on the back of the instrument—turns the instrument off and on during battery operation. When the AC adapter is attached, the instrument remains on and the battery switch has no effect.

As an added feature to conserve battery life, the instrument automatically powers down when it is not in use. You can define the amount of time it takes to initiate a power-down within the instrument configuration options (*see Section Four*). Taking a measurement or pressing a key turns the instrument back on during a power-down. However, if the instrument is turned off with the battery switch you must turn it back on with the battery switch.

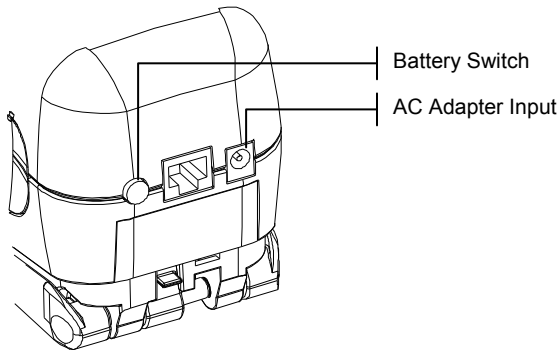

## Charging the Battery Pack

**NOTE:** The battery pack must be installed before plugging in the AC Adapter.

Only use the AC Adapter supplied. The battery pack must remain in the instrument at all times to operate.

Before initial “remote” use of the instrument, charge the battery pack for approximately four hours. However, if immediate use is required, the instrument can be operated “tethered” to the AC adapter during battery charging.

### To attach the AC adapter:

1. Verify that the voltage indicated on the adapter complies with the AC line voltage in your area. If not, contact X-Rite or an authorized representative.
2. Insert the small plug from the adapter into the power-input connector on the instrument. (If you are using serial cable SE108-92, you may insert the small plug into the power connector at the end of the cable.)
3. Plug the detachable line cord into the adapter.
4. Plug the line cord into an AC wall receptacle.



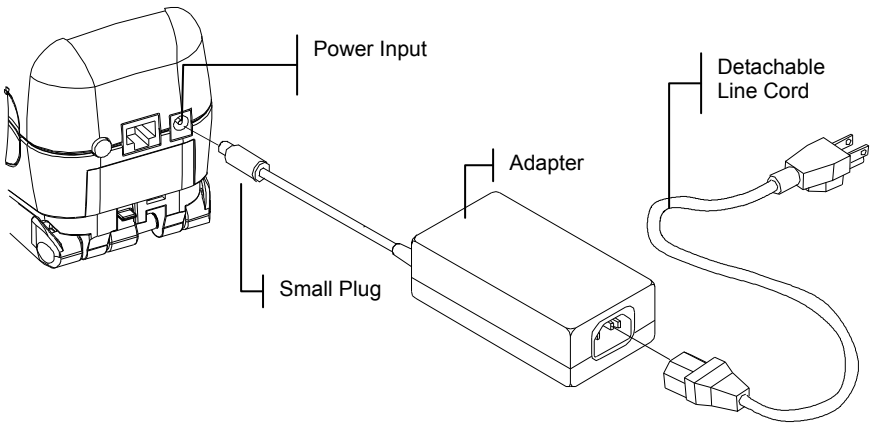

## Unlatching the Instrument Shoe

The shoe can be pivoted open 180° from its closed position. This feature is useful when taking measurements on a surface that does not allow room for the shoe, or a measurement fixture that does not require the shoe. Measurements are then activated using the Read key (see *Instrument Configuration for more details on the Read key*).

**NOTE:** The instrument must be calibrated with the target window removed when using the instrument with the shoe extended.

### To Unlatch the Instrument Shoe:

1. Hold the shoe next to the instrument housing and lift upward on the spring-loaded latch.
2. Slowly allow the shoe to pivot toward the back of the instrument and release the latch.

**NOTE:** The shoe latch should be released before pivoting the shoe. If you forget to release the latch before pivoting the shoe this should not cause any damage to the latch or shoe. However, repeated opening of the shoe without releasing the latch could result in a worn or weakened latch.

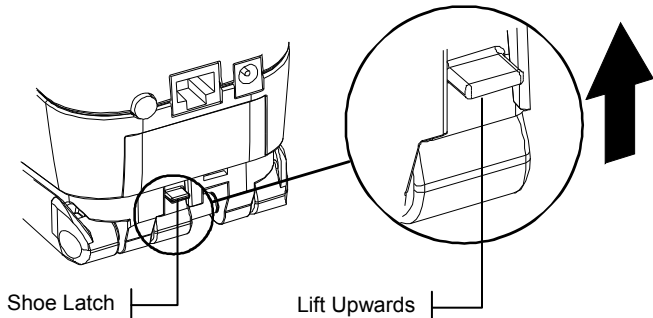

**To latch the Instrument Shoe:**

1. Simply close the shoe to the instrument. The latch is spring-loaded and automatically latches to the shoe catch.

**Instrument I/O Serial Interface**

Your instrument can be connected to a computer or printer using a serial RS-232 interface cable and adapter. X-Rite carries a variety of adapters to meet your requirements.

**To install the interface cabling:**

1. Insert the modular end of the interface cable into the I/O port located on the back of the instrument. The cable connector “clicks” when properly attached.
2. If required, attach an additional adapter to the other end of the cable.

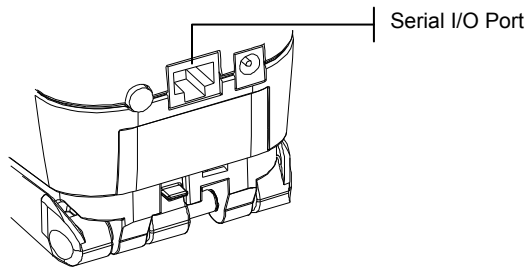
**Attaching the Wrist Strap**

A security wrist strap is included to safeguard against accidentally dropping the instrument. The strap is attached to the instrument by simply securing the clasp to the designated location on the back of the housing. Adjust the strap by sliding the sleeve to tighten around your wrist.

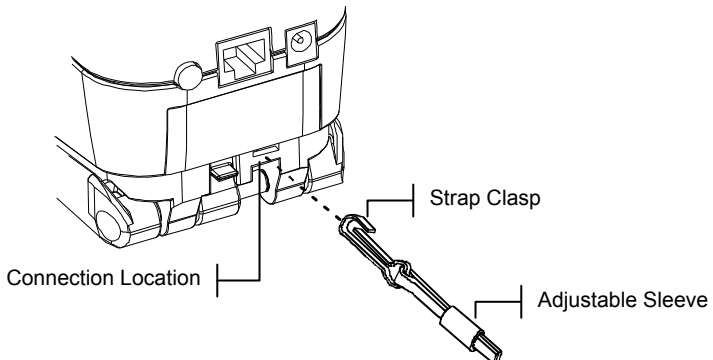

CHAPTER ONE

# User Interface

What to Expect	2-1
Navigation – Basic Key Operation	2-1
Measurement Mode Screens	2-3
Using the Instrument	2-4

## What to Expect

When the instrument is powered-up, the main (top level) screen appears. The main screen consists of two areas, Main Menu and Instrument Data. The left side of the screen lists all available modes. The right side of the screen lists instrument model and firmware version information.

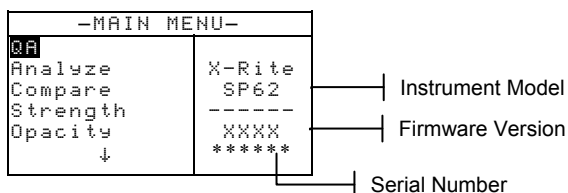

## Navigation – Basic Key Operation

Perform reading and menu/option navigation with the six keys arranged around the display screen. Each key has a unique symbol for performing a specific operation.

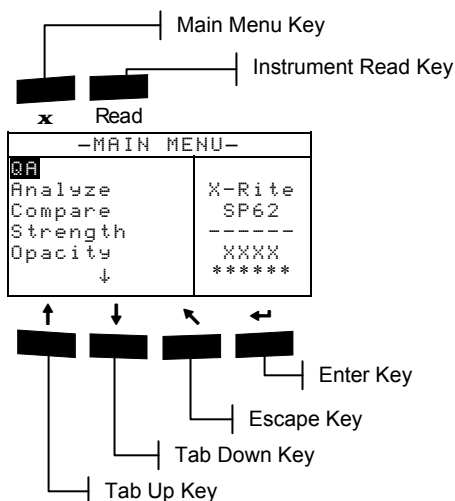



### **Tab Down key**

Advances the highlighted bar (reverse image) to the next available “tab stop.” A “tab stop” indicates an item that can be acted on further, such as a measurement or a setting option. Tab stops generally follow a left-to-right or top-to-bottom sequence. When the last tab stop is reached, the next key press returns to the first tab stop in that menu's list. The key is also used to select alpha/numeric characters in the edit mode.



### **Tab Up key**

Performs the same function as the Tab Down key except in reverse order. Tab stops follow a right-to-left or bottom-to-top sequence.



### **Enter key**

Activates the highlighted item. If the item can be set on or off, pressing the key toggles the option between on and off. When entering an active mode from the main menu, the active mode is displayed with the highlight on the first required operation in the mode.



### **Escape key**

Backs up the instrument screen one menu level. For example, if an option or value is being modified at the time the key is pressed, the edits are aborted and the previous screen or menu appears. The only exception to this is when the Enter key is used to toggle an option. In this case, the Escape key exits the menu without aborting the setting.



### **Main Menu key**

Returns the instrument screen to the main menu. This is a quick exit out of any mode. If any option or value is being modified at the time the key is pressed, the edits are aborted and the previous setting reinstated.

### **Read key**

If activated in configuration, initiates a reading when pressed. *Refer to Setting Instrument Configuration, Section Two for additional information.*

## Measurement Mode Screen

The QA, Analyze, Compare, Strength, and Opacity measurement screens consist of three main areas: Data Storage Information, Color Data Parameters, and Color Data.

Data Storage Information	Proj 1: Cartons			Color Data
	Std 1: Red Sample			
	Sample: #10 11:23			
Color Data Parameters	L*a*b*		$\Delta L^*$ +0.05	
	D65/10	L* 88.25	$\Delta a^*$ -0.03	
	SPIN	a* -4.71	$\Delta b^*$ -0.14	
	..*..*	b*+36.64	$\Delta E^*$ 0.16	

### Data Storage Information

When in QA, Strength, or Opacity mode, this area displays the project, standard, and sample information associated with stored data. Repeatedly pressing the Enter key  $\leftarrow$  when **Proj ###** or **Std ###** is highlighted pages through the available projects or standards stored in the instrument (or hold down the Enter key  $\leftarrow$  to access a specific number from the editor dialog). Pressing the Enter key  $\leftarrow$  when **Sample** is highlighted activates the sample Database Tools menu. Pressing the Enter key  $\leftarrow$  when a project name or a standard name is highlighted displays the setup information for the selected item. When the instrument is in storage mode, repeatedly pressing the Enter key  $\leftarrow$  with the sample number highlighted pages through samples associated with the current standard and project (or hold down the Enter key  $\leftarrow$  to access a specific number from the editor dialog).

When in Analyze mode, this area displays the standard's name. Pressing the Enter  $\leftarrow$  key when **Std ###** is highlighted pages through the available standards stored in the instrument.

When in Compare mode this area displays measurement instructions.

### Color Data Parameters

This portion of the screen lists the current parameters for the values displayed in the Color Data Area. *See Selecting Color Data Parameters for additional information.*

### Color Data

This portion of the screen instantaneously displays measurement data for the active measurement mode.

Depending on the mode and configuration settings, data appears as absolute or absolute and difference values.

### Using the Instrument

There are several techniques used to navigate through the instrument screens, select functions and settings, and determine values and names.

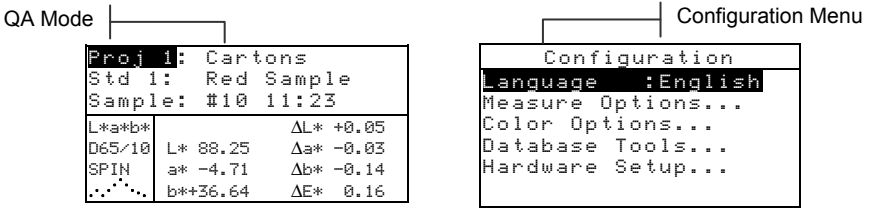

### Opening a Menu or Mode

Opening a mode or a menu gives you access to additional items related to the menu or specific information for a mode. Below are examples of typical mode and menu screens.

#### To open a mode or menu:

1. Use the Tab Up key  $\uparrow$  or Tab Down key  $\downarrow$  to highlight the desired mode or menu item.
2. Press the Enter  $\leftarrow$  key.

### Opening a Pop-Up List Box

Opening a pop-up list box allows you to select items and/or change settings for a selection or function. Below is an example of a list box.

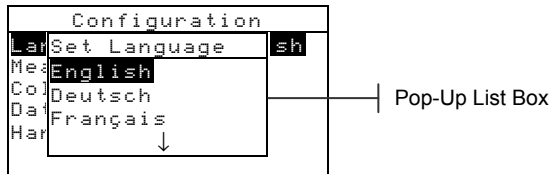

#### To open an pop-up list box:

1. Use the Tab keys  $\updownarrow$  to highlight the desired selection or function.
2. Press the Enter  $\leftarrow$  key to access the pop-up list box.

## Opening the Alphanumeric Editor

Several functions that utilize names and values are edited using the alphanumeric editor. Selecting `Clear` in the editor provides a quick method of removing all values or characters in the string. Pressing the Tab keys  $\updownarrow$  simultaneously clears the selected character. Below is an example of the editor.

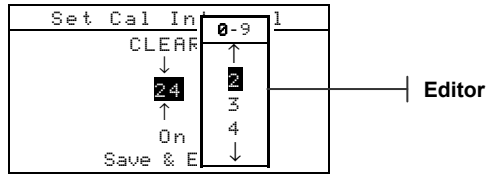

### To open the editor:

1. Use the Tab keys  $\updownarrow$  to choose the desired digit or number (arrows above and below designate selection).
2. Press the Enter  $\leftarrow$  key to access the editor.

**NOTE:** If the editor menu includes letters and symbols (such as the standard name editor), you can press the Enter key  $\leftarrow$  again to quickly page through groups of letters, symbols, and numbers.

3. Use the Tab keys  $\updownarrow$  to highlight the desired item.
4. Press the Enter  $\leftarrow$  key to select the highlighted character and exit the editor.

## Selecting Single or Multiple Items

Many settings and modes allow you to select single or multiple items from a list or menu. Lists can be found in every type of screen: menus, editors, or mode screens.

### To select a single item from a list:

1. Use the Tab keys  $\updownarrow$  to highlight the desired item in the list.
2. Press the Enter key  $\leftarrow$  to save your selection (and return to the previous screen).

### To select multiple items from a list:

1. Use the Tab keys  $\updownarrow$  to highlight the first item in the list.
2. Press the Enter key  $\leftarrow$  to toggle an arrow ( $>$ ) on or off for the item (an arrow indicates on).
3. Use the Tab keys  $\updownarrow$  to move the highlight to the next item in the list and press the Enter key  $\leftarrow$  to set status.
4. Press the Escape key  $\backslash$  to return to the previous screen.



### Selecting Color Data Parameters

Measured data can be viewed under varying illuminant observer conditions, specular components (included or excluded), and color space/indices. The color data immediately changes to reflect the selected parameter.

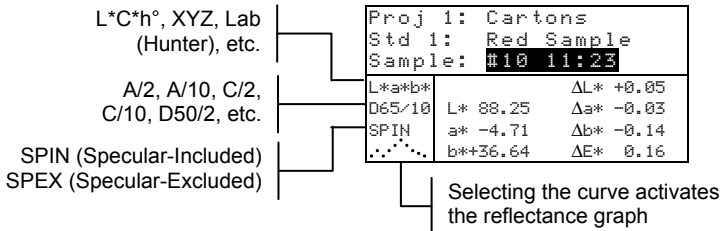

#### To select a color data parameter:

1. Use the Tab keys  $\uparrow \downarrow$  to highlight the desired parameter.
2. Press the Enter key  $\leftarrow$  to page through the parameters.

### Instrument Indicator Light

The LED located next to the display illuminates various color conditions during instrument measurements.

- Flashing Amber – instrument calibration is required or measurement aborted.
- Solid Amber – measurement is taking place.
- Solid Green – measurement passed tolerancing requirement in QA mode.
- Solid Red – measurement failed tolerancing requirements in QA mode.

### Important Measurement Techniques

In order for the instrument to obtain accurate and repeatable measurements, the bottom of the shoe must be flat on the surface to be measured. When measuring curved items where a flat surface is not available, a fixture should be used. A fixture allows accurate positioning of the sample tangent to the measurement plane. If the item to be measured is smaller than the shoe, you may want to make a platform—at the same height as the item—for the rest of the instrument to sit on. The instrument can also be used with the shoe fully extended 180° from the closed position. A measurement is then activated using the Read key.

# Instrument Calibration

General Information	3-1
Positioning the Instrument on the Reference	3-2
Calibration Procedure	3-3

## General Information

Under normal circumstances, the instrument should be calibrated at least once a day.

At the Main Menu, use the Tab Up ↑ or Tab Down ↓ key to highlight **Calibrate**. Press the Enter key ↵ to access the Calibration Menu.

CALIBRATION
<Measure White Ref>
Status: Cal time up
S/N: *****
Ap Size: 4.0mm

The bottom portion of the calibration screen displays information regarding the calibration status, cal plaque serial number, and instrument aperture size. The status line displays as either Cal OK or Cal time up. Cal time up indicates that calibration is required. Cal Ok indicates that no calibration is required at this time. The serial number displayed on the second line should match the serial number listed on your calibration reference. The aperture size line displays the current size. For the SP64, this indicates the current position of the aperture knob on the bottom of the instrument.

## Positioning the Instrument on the Reference

The calibration reference consists of a ceramic disk for white calibration measurements and a trap opening for black calibration measurements. The instrument shoe fits snugly in both positions. *Refer below for proper positioning.*

■ **NOTE:** Make sure the calibration reference is clean before use. Refer to the calibration cleaning procedure in Section Six.

### White Reading Position

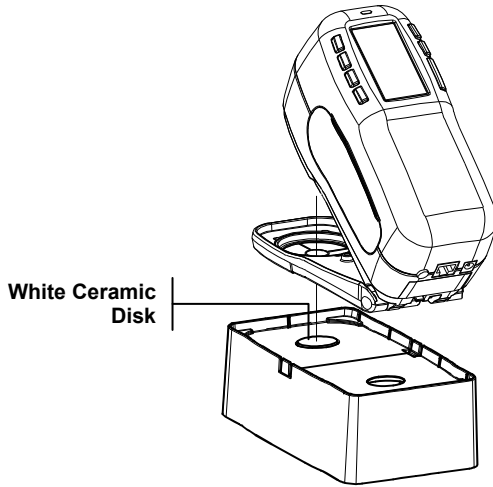

### Black Reading Position

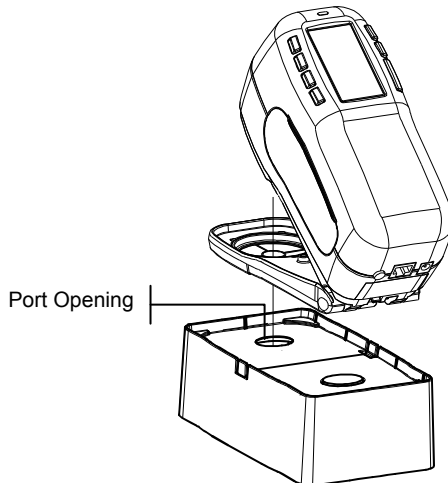

## Calibration Procedure

A calibration procedure consists of a white measurement followed by a black measurement. The instrument features a built in calibration timer that can be set from 1-96 hours. *Refer to Instrument Configuration for procedure.* The instrument then notifies you when a calibration is required.

**NOTE:** The instrument must be calibrated with the target window removed when using the instrument with the shoe extended (unlatched).

### To perform a calibration:

1. At the Calibration menu screen, position the target window over the white ceramic disk as previously explained.
2. Press the instrument firmly to the shoe. Hold steady until the screen indicates the white calibration is completed. Release instrument when <Success!> is displayed.
3. Position the target window over the black port opening as previously explained.
4. Press the instrument firmly to the shoe. Hold steady until the screen indicates the black calibration is completed.
5. Store the calibration reference in a dry, dust free area, away from direct exposure to light.

CHAPTER THREE

# Setting Instrument Configuration

General Information	4-1
Language	4-1
Measure Options	4-2
Color Options	4-5
Database Tools	4-11
Hardware Setup	4-14
Load Factory Defaults	4-24

## General Information

The Configuration menu consists of a series of settings that allow you to customize your instrument for your particular application.

### To open the Configuration menu:

1. Repeatedly press the Tab Down ↓ key to highlight **Configuration**. Press the Enter key ← to access the Configuration Menu.

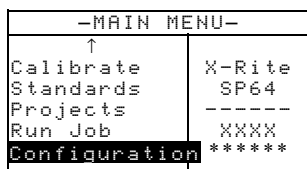

## Language

The Language configuration allows you to select the language you want to display on your instrument. The instrument resets whenever the language is changed.

### To select a language:

1. Use the Tab keys ↑↓ to highlight **Language**.
2. Press the Enter ← key to access the Language editor.

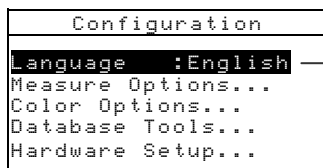

English, Deutsch,  
 Español, Français,  
 Italiano, Português, etc.

3. Use the Tab keys ↑↓ to highlight the desired language.
4. Press the Enter key ← to save the selected language. The instrument restarts with the selected language active.

## Measure Options

The Measure Options configuration allows you to determine the following settings:

- **Store Samples** – Allows you to enable (on) or disable (off) the measurement storage capabilities of the instrument. When set to “On”, measured samples are stored in the instrument database until manually deleted.
- **Pass/Fail** – Allows you to enable (on) or disable (off) the pass and fail capabilities of the instrument. When set to “On”, the measured data is compared to the current standard value (auto selected as closest color if Auto Std is On) and the associated tolerance to determine pass/fail status.
- **Auto Std** – Sets the automatic standard option. When Auto Standard is enabled (on), the standard with the smallest DE is automatically selected during a difference measurement. When Auto Standard is disabled (off), a standard must be manually selected before a difference measurement.
- **Averaging** – Sets the averaging option. Selects the number of readings averaged into a single measurement (0-99).
- **Diff Disp** – Selecting “Numbers” causes delta values to display during difference measurements. This option is automatically enabled when standards are entered or downloaded from a software program. When set to “Words”, color difference is displayed as words (e.g., brighter, duller, etc.). This setting is only available for L\*a\*b\* and L\*C\*h° color difference data. When disabled (off), no delta values are displayed during measurements.

**NOTE:** No words display for an attribute that is less than 1/7<sup>th</sup> of the DE value. A value less than this amount is considered insignificant compared to the total difference. Delta values greater than 10.00 display numerically.

**To open the Measure Options menu:**

1. Use the Tab keys **↑↓** to highlight **Measure Options**.

```

Configuration
Language      :English
Measure Options...
Color Options...
Database Tools...
Hardware Setup...

```

2. Press the Enter  $\leftarrow$  key to access the Measure Options menu.

## Store Samples

**To select the store sample status:**

1. Use the Tab keys  $\updownarrow$  to highlight **Store Samples**.

```

Measure Options
Store Samples is Off
Pass/Fail is Off
Auto Std is On
Averaging :1
Diff Disp :Off

```

2. Press the Enter  $\leftarrow$  key to toggle between Off and On.

## Pass/Fail

**To select the pass/fail status:**

1. Use the Tab keys  $\updownarrow$  to highlight **Pass/Fail**.

```

Measure Options
Store Samples is Off
Pass/Fail is Off
Auto Std is On
Averaging :1
Diff Disp :Off

```

2. Press the Enter  $\leftarrow$  key to toggle between Off and On.

## Auto Std

**To select the Auto Std status:**

1. Use the Tab keys  $\updownarrow$  to highlight **Auto Std**.

```

Measure Options
Store Samples is Off
Pass/Fail is Off
Auto Std is On
Averaging :1
Diff Disp :Off

```

2. Press the Enter  $\leftarrow$  key to toggle between Off and On.

## Averaging

**To set the Averaging Option:**

1. Use the Tab keys  $\updownarrow$  to highlight **Averaging**.



```

Measure Options
Store Samples is Off
Pass/Fail is Off
Auto Std is On
Averaging :1
Diff Disp :Off
    
```

2. Press the Enter key ↵ to open the Edit Averaging # menu.

```

Edit Averaging #
CLEAR
  ↓
  01
  ↑
Save & Exit
    
```

3. Use the Tab keys ⇅ to highlight the averaging ###. Press the Enter key ↵ to access the alphanumeric editor.
4. Use the Tab keys ⇅ to highlight desired number and press the Enter ↵ key to exit editor.
5. Use the Tab keys ⇅ to highlight Save & Exit and press Enter ↵ key.

## Diff Disp

### To set the Difference Display Option:

1. Use the Tab keys ⇅ to highlight Diff Disp.

```

Measure Options
Store Samples is Off
Pass/Fail is Off
Auto Std is On
Averaging :1
Diff Disp :Off
    
```

2. Press the Enter key ↵ to open the Diff Display menu.
3. Use the Tab keys ⇅ to highlight the desired display method: Off, Numbers, or Words.
4. Press the Enter ↵ key to save your setting and return to the Measure Options menu.

## Color Options

The Color Options configuration allows you to determine the following settings:

- **Active Functions** – Allows you to select the colorimetric functions and indices that are available in the color data parameters. An arrow (>) indicates the function is active.
- **Active Illum/Obs** – Allows you to select the illuminant/observer combinations that are available in the color data parameters. An arrow (>) indicates the illum/obs combination is active.
- **Opacity** – Determines the data display method for opacity measurements, and allows k1 and k2 value editing.
  - Data Display** – Select Over White, Over Black, or Color at 100%.
  - Set k1 and k2** – Allows you to adjust the opacity constant of k1 and k2 for SPIN and SPEX.
- **Strength** – Determines the strength method and predicted mode.
  - Method** – Select Apparent, Chromatic, or Tristimulus as the strength calculation.
  - Predicted is @** – Select 100% or Min $\Delta E$  as the predicted mode.
- **Metamerism Index** – Determines the metamerism mode and Illuminant/Observer pairs used in calculating the metamerism index.
  - Mode** – Select MI or DIN6172 as the metamerism mode.
  - IIObs1 and IIObs2** – Select the illuminant observer combinations (D65/2, D65/10, etc.).
- **$\Delta E_{cmc}$  Factors** – Used to edit the Lightness and Chromaticity values for the selected calculation.
- **$\Delta E_{94}$  Factors** – Used to edit the Lightness and Chromaticity values for the selected calculation.
- **Shade Sort** – Allows you to enable (on) or disable the shade sort capabilities used in the QA mode. Shade sort options are accessed through the Standards mode and allow setting the shade sort and box size.
- **SP88 SPEX** - When enabled (on), specular values are calculated the same as X-Rite's SP88 instrument.

**To open the Color Options menu:**

1. Use the Tab keys **⇅** to highlight **Color Options**.

```

CONFIGURATION
Language      :English
Measure Options...
Color Options...
Database Tools...
Hardware Setup...
    
```

2. Press the Enter **↵** key to access the Color Options menu.

**Active Functions**

**To enable or disable functions:**

1. Use the Tab keys **⇅** to highlight **Active Functions**.

```

Color Options
Active Functions...
Active Illum/Obs...
Opacity          :Color
Strength        :Tristimu
Metamerism      :MI
                ↓
    
```

2. Press the Enter **↵** key to access the Act. Functions editor.
3. Use the Tab keys **⇅** to highlight the desired function.
4. Press the Enter key **↵** to toggle the function active or inactive. The > indicates the function is enabled.
5. After edits are complete, press the Escape key **⌫** to save and exit.

**Active Illum/Obs**

**To enable or disable illum/Obs combinations:**

1. Use the Tab keys **⇅** to highlight **Active Illum/Obs**.

```

Color Options
Active Functions...
Active Illum/Obs...
Opacity          :Color
Strength        :Tristimu
Metamerism      :MI
                ↓
    
```

2. Press the Enter **↵** key to access the Act. Illum/Obs. editor.
3. Use the Tab keys **⇅** to highlight the desired combination.

4. Press the Enter key ↵ to toggle the combination active or inactive. The > indicates the illum/obs is enabled.
5. After edits are complete, press the Escape key ⌫ to save and exit.

## Opacity

### To access the Opacity Option:

1. Use the Tab keys ⇄ to highlight **Opacity**.

```

Color Options
Active Functions...
Active Illum/Obs...
Opacity      :Color
Strength    :Tristimu
Metamerism  :MI
↓

```

2. Press the Enter ↵ key to access the Opacity menu.

```

Opacity Menu
Data Display :Color
Set SPIN k1  :0.04
Set SPIN k2  :0.60
Set SPEX k1  :0.00
Set SPEX k2  :0.60

```

### Data Display Selection

1. Use the Tab keys ⇄ to highlight **Data Display**. Press the Enter ↵ key to access the Set Data Display editor.
2. Use the Tab keys ⇄ to highlight the desired data display: Over White, Over Black, or Color at 100%. Press the Enter ↵ key to save your setting and return to the Opacity menu.

### Set SPIN/SPEX k1 and k2 Constants

1. Use the Tab keys ⇄ to highlight **Set SPIN k1**, **Set SPIN k2**, **Set SPEX k1**, or **Set SPEX k2**. Press the Enter ↵ key to access the Enter Const. editor.
2. Use the Tab keys ⇄ to highlight the desired digit (arrows above and below designate the selection). Press the Enter ↵ key to access the alphanumeric editor.

**NOTE:** Highlighting **CLEAR** and pressing the Enter key ↵ is a quick method to zero the value.

3. Use the Tab keys ⇄ to highlight the desired number and press the Enter ↵ key to exit editor.

4. When editing is complete, use the Tab keys  $\uparrow\downarrow$  to highlight Save & Exit and press the Enter  $\leftarrow$  key.

### Strength

**To access the Strength Options:**

1. Use the Tab keys  $\uparrow\downarrow$  to highlight Strength.

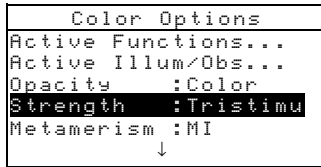

2. Press the Enter  $\leftarrow$  key to access Strength options.

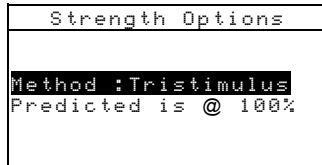

### Strength Method Selection

1. Use the Tab keys  $\uparrow\downarrow$  to highlight Method. Press the Enter  $\leftarrow$  key to access the Strength Method editor.
2. Use the Tab keys  $\uparrow\downarrow$  to highlight the desired method: Apparent, Chromatic, or Tristimulus. Press the Enter  $\leftarrow$  key to save your setting and return to the Strength Options menu.

### Predicted Selection

1. Use the Tab keys  $\uparrow\downarrow$  to highlight Predicted. Press the Enter  $\leftarrow$  key to toggle between @ 100% and @ Min $\Delta E$ .

### Metamerism Index

**To access the Metamerism Menu:**

1. Use the Tab keys  $\uparrow\downarrow$  to highlight Metamerism.

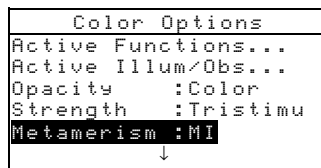

2. Press the Enter  $\leftarrow$  key to access the Metamerism menu.

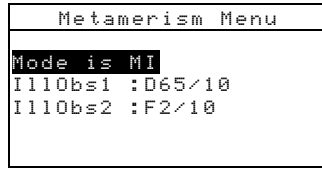

### Mode Selection

1. Use the Tab keys  $\updownarrow$  to highlight **Mode is**. Press the Enter  $\leftarrow$  key to toggle between MI and DIN6172.

### Illum/Obs Selections

1. Use the Tab keys  $\updownarrow$  to highlight **I11Obs1** or **I11Obs2**. Press the Enter  $\leftarrow$  key to access the MI I11Obs editor.
2. Use the Tab keys  $\updownarrow$  to highlight the desired combination: A2, A10, etc. Press the Enter  $\leftarrow$  key to save your setting and return to the Metamerism menu.

## $\Delta E_{cmc}$ Factors

### To access the $\Delta E_{cmc}$ Factors:

1. Use the Tab keys  $\updownarrow$  to highlight  **$\Delta E_{cmc}$  Factors**.



2. Press the Enter  $\leftarrow$  key to access  $\Delta E_{cmc}$  Factors options.

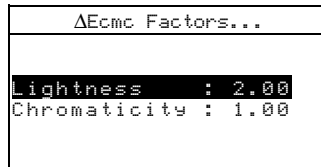

3. Use the Tab keys  $\updownarrow$  to highlight desired attribute. Press the Enter  $\leftarrow$  key to access the Set  $\Delta E_{cmc}$  Factor editor.
4. Use the Tab keys  $\updownarrow$  to choose the desired digit (arrows above and below designate selection). Press the Enter key  $\leftarrow$  to access the alphanumeric editor.

**NOTE:** Highlighting **CLEAR** and pressing the Enter key  $\leftarrow$  is a quick method to zero the value.

5. Use the Tab keys  $\updownarrow$  to highlight the desired number and press the Enter  $\leftarrow$  key to exit the editor.
6. When editing is complete, use the Tab keys  $\updownarrow$  to highlight `Save & Exit` and press the Enter  $\leftarrow$  key.

### $\Delta E_{94}$ Factors

To access the  $\Delta E_{94}$  Factors:

1. Use the Tab keys  $\updownarrow$  to highlight  `$\Delta E_{94}$  Factors`.



2. Press the Enter  $\leftarrow$  key to access  $\Delta E_{94}$  Factors options.

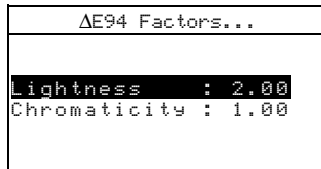

3. Use the Tab keys  $\updownarrow$  to highlight the desired attribute. Press the Enter  $\leftarrow$  key to access the Set  $\Delta E_{94}$  Factor editor.
4. Use the Tab keys  $\updownarrow$  to choose the desired digit (arrows above and below designate the selection). Press the Enter key  $\leftarrow$  to access the alphanumeric editor.

**NOTE:** Highlighting `CLEAR` and pressing the Enter key  $\leftarrow$  is a quick method to zero the value.

5. Use the Tab keys  $\updownarrow$  to highlight the desired number and press the Enter  $\leftarrow$  key to exit editor.
6. When editing is complete, use the Tab keys  $\updownarrow$  to highlight `Save & Exit` and press the Enter  $\leftarrow$  key.

### Shade Sort

To select the shade sort status:

1. Use the Tab keys  $\updownarrow$  to highlight `Shade Sort`.

```

Color Options
  ↑
Metamerism :MI
ΔEcmc Factors...
ΔE94 Factors...
Shade Sort is Off
SP88 Spex Mode: Off

```

2. Press the Enter ← key to toggle between Off and On.

## SP88 Spex Mode

To select the SP88 Spex Mode:

1. Use the Tab keys ⇄ to highlight **SP88 Spex Mode**.

```

Color Options
  ↑
Metamerism :MI
ΔEcmc Factors...
ΔE94 Factors...
Shade Sort is Off
SP88 Spex Mode: Off

```

2. Press the Enter ← key to toggle between Off and On.

## Database Tools

The Database Tools configuration allows you to determine the following settings:

- **View Tags** – Used to view the current tags that were scanned in the instrument, if applicable.
- **Factory Presets** – Allows you to reload the factory default settings whenever required. **All configuration options and stored data will be lost.**
- **Clear all Databases** – Allows you to clear all stored data from the instrument. Configuration settings are not affected.
- **Clear all Samples** – Allows you to clear all stored samples.
- **Clear all Tags** – Allows you to clear all stored tags.
- **Clear all Projects** – Allows you to clear all stored projects.
- **Clear all Jobs** – Allows you to clear all stored jobs (SP64 instrument only).
- **Clear all Standards** – Allows you to clear all stored standards.



**To open the Database Tools menu:**

1. Use the Tab keys **⇅** to highlight **Database Tools**.

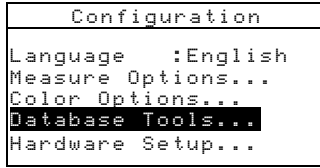

2. Press the Enter **↵** key to access the Database Tools menu.

**Factory Presets**

**NOTE:** All configuration options and stored data will be lost when reloading the factory defaults.

**To restore factory presets:**

1. Use the Tab keys **⇅** to highlight **Factory Presets**.



2. Press the Enter key **↵** to open the Factory Defaults window.
3. Use the Tab keys **⇅** to highlight **Yes** and press the Enter key **↵**. The factory defaults are now loaded in the instrument.

**Clear all Databases**

**To clear database:**

1. Use the Tab keys **⇅** to highlight **Clear all Databases**.



2. Press the Enter key **↵** to open the Delete all Databases window.
3. Use the Tab keys **⇅** to highlight **Yes** and press the Enter key **↵**. The instrument's database is now deleted.

## Clear All Samples

To clear all samples:

1. Use the Tab keys  $\updownarrow$  to highlight **Clear all Samples**.

```

Database Tools
View Tags...
Factory Presets...
Clear all Databases
Clear all Samples
Clear all Tags
↓

```

2. Press the Enter key  $\leftarrow$  to open the Delete Samples window.
3. Use the Tab keys  $\updownarrow$  to highlight **Yes** and press the Enter key  $\leftarrow$ . The instrument's samples are now deleted.

## Clear All Tags

To clear all tags:

1. Use the Tab keys  $\updownarrow$  to highlight **Clear all Tags**.

```

Database Tools
View Tags...
Factory Presets...
Clear all Databases
Clear all Samples
Clear all Tags
↓

```

2. Press the Enter key  $\leftarrow$  to open the Delete Tags window.
3. Use the Tab keys  $\updownarrow$  to highlight **Yes** and press the Enter key  $\leftarrow$ . The instrument's samples are now deleted.

## Clear All Projects

To clear all projects:

1. Use the Tab keys  $\updownarrow$  to highlight **Clear all Projects**.

```

Database Tools
↑
Clear all Databases
Clear all Samples
Clear all Tags
Clear all Projects
↓

```

2. Press the Enter key  $\leftarrow$  to open the Delete Projects window.
3. Use the Tab keys  $\updownarrow$  to highlight **Yes** and press the Enter key  $\leftarrow$ . The instrument's projects are now deleted.

## Clear All Jobs (SP64 only)

To clear all jobs:

1. Use the Tab keys  $\updownarrow$  to highlight **Clear all Jobs**.

```

Database Tools
  ↑
Clear all Samples
Clear all Tags
Clear all Projects
Clear all Jobs
Clear all Standards
    
```

2. Press the Enter key  $\leftarrow$  to open the Delete Jobs window.
3. Use the Tab keys  $\updownarrow$  to highlight **Yes** and press the Enter key  $\leftarrow$ . The instrument's jobs are now deleted.

## Clear All Standards

To clear all standards:

1. Use the Tab keys  $\updownarrow$  to highlight **Clear all Standards**.

```

Database Tools
  ↑
Clear all Samples
Clear all Tags
Clear all Projects
Clear all Jobs
Clear all Standards
    
```

2. Press the Enter key  $\leftarrow$  to open the Delete Standard window.
3. Use the Tab keys  $\updownarrow$  to highlight **Yes** and press the Enter key  $\leftarrow$ . The instrument's standards are now deleted.

## Hardware Setup

The Hardware Setup configuration allows you to determine the following settings:

- **Serial Port** – Allows you to edit the following settings that affect data transmitted from the RS-232 Port.

**Baud Rate** – Choose the correct baud rate.

**Hand Shake** – Set the method of handshaking between the instrument and your computer. There are four handshake methods: Off, CTS (ensures instrument is working before sending a handshake), BUSY, or XON.

**Auto XMT** – Enable (on) or disable (off) automatic transmission of measured data.

**Separator** – Determines the character that separates the data components of a measurement: Space, Comma, Tab, CR (carriage return), CRLF (carriage return, line feed), LF (line feed).

**Delimiter** – Determines the character that terminates the string of measured data: CR (carriage return), CRLF (carriage return, line feed), or LF (line feed).

**Set Data Types** – Determines the type of data that is transmitted after a measurement (if Auto XMT is on or when requested by an RCI command). Available data types are SPIN Colorimetric, SPEX Colorimetric, SPIN Reflectance, and SPEX Reflectance.

**Header** – Enables (on) or disables (off) the header from printing during a data transmit.

**Std Printout** – Enables (on) or disables (off) the standard from printing during a data transmit. If “Diff Disp” is turned off in Measure Options, no standard will print, regardless of this setting.

**Emulation** – (SP62 and SP64 only) Enables the instrument to emulate other instrument outputs. When set to Off, the instrument communicates normally. When set to SP68, the instrument duplicates the SP68 communication (including RCI version command response) allowing communication with older X-Rite software packages (QA-Master, Paint-Master, etc.)

- **Read Operation**– Determines the method that is used to take a measurement.
  - RCI Only** – A measurement can only be initiated through an RCI command via the RS-232 port.
  - Switch Only** – The instrument read switch initiates a measurement.
  - Key Only** – The Read key on the instrument must be pressed to initiate a measurement.
  - Switch and Key** – Both the instrument’s read switch and read key are required to initiate a measurement.
- **Cal Timeout** – Determines the “cal interval time” desired between calibrations. Time is set in hour increments and can also be set to Off. When a calibration is required, a message appears on the instrument screen informing you that a calibration is needed.
- **Power Down** – Determines the amount of time the unit remains on without any use before turning itself off. This

configuration only affects the instrument when the charger is *not* connected. This value can range from 10 to 240 seconds.

- **Beeper** – Sets the volume of the beeper: Loud, Medium, Soft, or Off.
- **Clock Adjust** – Used to adjust the internal clock of the instrument.
- **Display** – Allows you to determine the following settings:

**Contrast** – Set the contrast of the display for optimal viewing. The setting can vary from 01 to 99.

**Orientation** – Determine whether you want the display viewable for right-handed (right) or left-handed (left) use.

**Security** – When security is activated (on) the Configuration options menu will not appear on the instrument screen. *See following steps to access the Configuration menu when Security is activated (on).*

**Unit ID** – This unique number identifies the instrument. *This number cannot be changed.*

**Error Log** – Used by X-Rite’s Customer Support to identify where an error condition occurred in the instrument.

**To gain access to the Configuration menu if Security is enabled:**

1. Remove the AC adapter and turn off the instrument with the battery switch.
2. Press and hold the Read key as you turn the instrument on with the battery switch.
3. When the main menu appears, release the Read key. The Configuration item appears in the main menu.

**NOTE:** You must set the Security to **Off** if you want the Configuration item to automatically appear the next time you turn the instrument on.

**To open the Hardware Setup menu:**

1. Use the Tab keys  $\uparrow\downarrow$  to highlight **Hardware Setup**.

```

Configuration
Language   :English
Measure Options...
Color Options...
Database Tools...
Hardware Setup...
  
```

2. Press the Enter  $\leftarrow$  key to access the Hardware Setup menu.

**Serial Port****To access the Serial Port Options:**

1. Use the Tab keys  $\uparrow\downarrow$  to highlight **Serial Port**.

```

Hardware Settings
Serial Port :9600
Read Oper.  :Switch
Cal Timeout :24 hrs
Power Down  :120 sec
Beeper     :Soft
           ↓
  
```

2. Press the Enter  $\leftarrow$  key to access the Serial Port options.

**Baud Rate Selection**

1. Use the Tab keys  $\uparrow\downarrow$  to highlight **Baud Rate**. Press the Enter  $\leftarrow$  key to access the Baud Rate editor.

```

Serial Port Options
Baud Rate :9600
Hand Shake:Off
Auto XMT is Off
Separator :Comma
Delimiter :CRLF
           ↓
  
```

2. Use the Tab keys  $\uparrow\downarrow$  to highlight the desired baud rate: 300 through 57600. Press the Enter  $\leftarrow$  key to save your setting and return to the Serial Port Options menu.

**Hand Shake Selection**

1. Use the Tab keys  $\uparrow\downarrow$  to highlight **Hand Shake**. Press the Enter  $\leftarrow$  key to access the Hand Shake editor.
2. Use the Tab keys  $\uparrow\downarrow$  to highlight the desired handshake method: Off, CTS, BUSY, or XON. Press the Enter  $\leftarrow$  key to save your setting and return to the Serial Port Options menu.

**Auto XMT Selection**

1. Use the Tab keys **↑↓** to highlight **Auto XMT**.
2. Press the Enter **↵** key to toggle between **Off** and **On**.

**Separator Selection**

1. Use the Tab keys **↑↓** to highlight **Separator**. Press the Enter **↵** key to access the Separator editor.
2. Use the Tab keys **↑↓** to highlight the desired separator command: **Space**, **Comma**, **Tab**, **CR**, **CRLF**, or **LF**. Press the Enter **↵** key to save your setting and return to the Serial Port Options menu.

**Delimiter Selection**

1. Use the Tab keys **↑↓** to highlight **Delimiter**. Press the Enter **↵** key to access the Delimiter editor.
2. Use the Tab keys **↑↓** to highlight the desired delimiter command: **CR**, **CRLF**, or **LF**. Press the Enter **↵** key to save your setting and return to the Serial Port Options menu.

**Data Types Selection**

1. Use the Tab keys **↑↓** to highlight **Set Data Types**. Press the Enter **↵** key to access the Pick Data Types editor.
2. Use the Tab keys **↑↓** to highlight the desired data type.
3. Press the Enter key **↵** to toggle the data type active or inactive. The **>** indicates the data type is enabled.
4. After edits are complete, press the Escape key **⌘** to save and exit.

**Header Selection**

1. Use the Tab keys **↑↓** to highlight **Header**.
2. Press the Enter **↵** key to toggle between **Off** and **On**.

**Std Printout Selection**

1. Use the Tab keys **↑↓** to highlight **Std Printout**.
2. Press the Enter **↵** key to toggle between **Off** and **On**.

**Emulation Selection**

1. Use the Tab keys **↑↓** to highlight **Emulation**. Press the Enter **↵** key to access the Emulation Mode editor.
2. Use the Tab keys **↑↓** to highlight the desired emulation mode: **Off** or **SP68**. Press the Enter **↵** key to save your setting and return to the Serial Port Options menu.

## Read Operation

To access the Read Operation Options:

1. Use the Tab keys  $\uparrow\downarrow$  to highlight **Read Oper.**.

```

Hardware Settings
Serial Port :9600
Read Oper. :Switch
Cal Timeout :24 hrs
Power Down :120 sec
Beeper     :Soft
          ↓
    
```

2. Press the Enter  $\leftarrow$  key to access the Read Operation options.
3. Use the Tab keys  $\uparrow\downarrow$  to highlight the desired read operation mode: RCI Only, Switch Only, Key Only, or Switch and Key. Press the Enter  $\leftarrow$  key to save your setting and return to the Hardware Settings Options menu.

## Cal Timeout

To access the Cal Interval Setup:

1. Use the Tab keys  $\uparrow\downarrow$  to highlight **Cal Timeout**.

```

Hardware Settings
Serial Port :9600
Read Oper. :Switch
Cal Timeout :24 hrs
Power Down :120 sec
Beeper     :Soft
          ↓
    
```

2. Press the Enter  $\leftarrow$  key to open the Set Cal Interval menu.

```

Set Cal Interval
CLEAR
  ↓
 24
  ↑
  On
Save & Exit
    
```

3. Use the Tab keys  $\uparrow\downarrow$  to choose the desired cal interval digit (arrows above and below designate selection). Press the Enter key  $\leftarrow$  to access the alphanumeric editor.

■ **NOTE:** Highlighting **CLEAR** and pressing the Enter key  $\leftarrow$  is a quick method to zero the value.

4. Use the Tab keys  $\uparrow\downarrow$  to highlight the desired number and press the Enter  $\leftarrow$  key to exit the editor. If desired, change the cal interval status from On to Off.



- When editing is complete, use the Tab keys **↑↓** to highlight **Save & Exit** and press the Enter **↵** key.

## Power Down

**To access the Power Down Setup:**

- Use the Tab keys **↑↓** to highlight **Power Down**.

```

Hardware Settings
Serial Port :9600
Read Oper. :Switch
Cal Timeout :24 hrs
Power Down :120 sec
Beeper      :Soft
              ↓
    
```

- Press the Enter **↵** key to open the Power Down Time menu.

```

Power Down Time
CLEAR
  ↓
 120
  ↑
Save & Exit
    
```

- Use the Tab keys **↑↓** to choose the desired power down digit (arrows above and below designate selection). Press the Enter key **↵** to access the alphanumeric editor.

**NOTE:** Highlighting **CLEAR** and pressing the Enter key **↵** is a quick method to zero the value.

- Use the Tab keys **↑↓** to highlight the desired number and press the Enter **↵** key to exit editor.
- When editing is complete, use the Tab keys **↑↓** to highlight **Save & Exit** and press the Enter **↵** key.

## Beeper

**To access the Beeper Options:**

- Use the Tab keys **↑↓** to highlight **Beeper**.

```

Hardware Settings
Serial Port :9600
Read Oper. :Switch
Cal Timeout :24 hrs
Power Down :120 sec
Beeper      :Soft
              ↓
    
```

- Press the Enter **↵** key to open the Beeper menu.

- Use the Tab keys  $\updownarrow$  to highlight the desired beeper volume: Loud, Medium, Soft, or Off. Press the Enter  $\leftarrow$  key to save your setting and return to the Hardware Settings Options menu.

## Clock Adjust

**To access the Clock Adjustment:**

- Use the Tab keys  $\updownarrow$  to highlight **Clock Adjust**.

Hardware Settings	
	↑
Cal Timeout	:24 hrs
Power Down	:120 sec
Beeper	:Soft
<b>Clock Adjust</b>	<b>: 8:21</b>
Display	:Right

- Press the Enter  $\leftarrow$  key to open the Clock Adjust menu.

Clock Adjust	
<b>Date Format</b>	<b>:M/D/Y</b>
Month	: 3
Day	:10
Year	:1999
Hour	: 8
Minute	:21

### Date Format Selection

- Use the Tab keys  $\updownarrow$  to highlight Date Format and press the Enter  $\leftarrow$  key.
- Use the Tab keys  $\updownarrow$  to highlight the desired date format: M/D/Y, Y/D/M or D/M/Y. Press the Enter  $\leftarrow$  key to save your setting and return to the Clock Adjust menu.

### Date Setting

- Use the Tab keys  $\updownarrow$  to highlight Month and press the Enter  $\leftarrow$  key to open the Set Month menu.

Set Month	
	CLEAR
	↓
	<b>03</b>
	↑
	Save & Exit

- Use the Tab keys  $\updownarrow$  to choose the desired month digit (arrows above and below the designate selection). Press the Enter key  $\leftarrow$  to access the alphanumeric editor.

- **NOTE:** Highlighting **CLEAR** and pressing the Enter key ↵ is a quick method to zero the value.
- 3. Use the Tab keys ↑↓ to highlight desired number and press the Enter ↵ key to exit the editor.
- 4. When editing is complete, use the Tab keys ↑↓ to highlight **Save & Exit** and press the Enter ↵ key.
- 5. Continue with Day and Year setting if required.

**Time Setting**

1. Use the Tab keys ↑↓ to highlight Hour and press the Enter ↵ key to open the Set Hour menu.
2. Use the Tab keys ↑↓ to highlight the desired hour digit (arrows above and below designate the selection). Press the Enter key ↵ to access the alphanumeric editor.

■ **NOTE:** Highlighting **CLEAR** and pressing the Enter key ↵ is a quick method to zero the value.

3. Use the Tab keys ↑↓ to highlight the desired number and press the Enter ↵ key to exit the editor.
4. When editing is complete, use the Tab keys ↑↓ to highlight **Save & Exit** and press the Enter ↵ key.
5. Continue with Minute setting if required.

**Display**

**To access the Display Options:**

1. Use the Tab keys ↑↓ to highlight **Display**.

```

Hardware Settings
      ↑
Cal Timeout :24 hrs
Power Down  :120 sec
Beeper      :Soft
Clock Adjust: 8:21
Display     :Right
    
```

2. Press the Enter ↵ key to open the Display menu.

```

Display
Contrast   :52
Orientation:Right
Security is Off
Unit ID    :#####
Error Log...
    
```

**Contrast Setting**

1. Use the Tab keys ↑↓ to highlight **Contrast**.



2. Press the Enter  $\leftarrow$  key to access the Set Display Contrast editor.

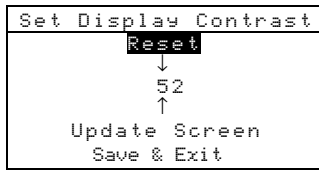

3. Use the Tab keys  $\updownarrow$  to choose the desired contrast digit (arrows above and below designate the selection). Press the Enter key  $\leftarrow$  to access the alphanumeric editor.

**NOTE:** Highlighting **Reset** and pressing the Enter key  $\leftarrow$  quickly restores the factory default setting.

4. Use the Tab keys  $\updownarrow$  to highlight desired number and press the Enter  $\leftarrow$  key to exit editor.
5. Highlight **Update Screen** and press the Enter key  $\leftarrow$  to immediately view your setting. Highlight **Save & Exit** and press the Enter  $\leftarrow$  key to save your setting.

### Orientation Selection

1. Use the Tab keys  $\updownarrow$  to highlight Orientation and press the Enter  $\leftarrow$  key.

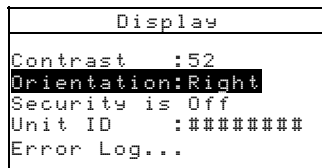

2. Use the Tab keys  $\updownarrow$  to highlight the desired orientation: **Right** or **Left**. Press the Enter  $\leftarrow$  key to save your setting and return to the Display menu.

### Security Mode

1. Use the Tab keys  $\uparrow\downarrow$  to highlight Security.



2. Press the Enter  $\leftarrow$  key to toggle between Off and On.

### Load Factory Defaults

The instrument can be reset to its original state whenever required. All configuration settings and function options are set to the factory defaults. **Restoring the defaults also clears all stored standards, samples, and tag data in the instrument.**

#### To initiate a factory default reload:

1. Unplug the AC Adapter (if connected) and press the power switch to Off. Simultaneously press and hold the Tab Down key  $\downarrow$  and Main Menu key  $\times$ .
2. Press the power switch to On. The X-Rite logo momentarily appears followed by Factory Defaults, Settings have been restored. Press the Enter  $\leftarrow$  key to clear the message dialog.

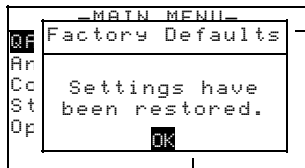

# Instrument Operations

Standards Mode	5-1
Projects Mode	5-11
QA Mode	5-15
Strength Mode	5-23
Opacity Mode	5-25
Analyze Mode	5-27
Compare Mode	5-28
Run Job Mode (SP64 only)	5-29

## Standards Mode

The standards mode accesses the Edit Standard menu. From this menu, standard data can be measured or manually entered, and specific tolerances and shade sort options can be entered for each standard.

The standards serve as approved references against which your sample measurements are evaluated using QA, Strength, Opacity or Analyze mode.

Standards can also be downloaded to the instrument from an X-Rite software package, such as X-RiteColor® Master (SP62 and SP64 only). Then, after sample measurements are performed, data is uploaded to the software package, where it is analyzed.

The main Standard screen gives the status of the standard last selected.

### To open the Edit Standard menu:

1. Repeatedly press the Tab Down ↓ key to highlight **Standards**. Press the Enter key ↵ to access the Edit Standards Menu.

-MAIN MENU-	
↑	
Calibrate	X-Rite
<b>Standards</b>	SP64
Projects	-----
Run Job	XXXX
Configurati	*****

## Selecting Standard Number

The standard number allows you to select existing standards for editing, or the next available standard location for entering a new standard.

The Standard Entry field displays “Empty”, when an available standard location is selected. This is the location you would use to enter a new standard.

**To access a new or existing standard location:**

1. Use the Tab keys  $\uparrow\downarrow$  to highlight the standard **1** in the Edit Standard field.

```

Edit Standard : 1
Std Entry: Measured
Std Name : Blue Sample
Tolerances...
Shade Sort Opts...
Std Lock : Unlocked
Delete THIS Std...
    
```

The field indicates the status of the standard (measured, manual, downloaded, or empty)

2. Press the Enter key  $\leftarrow$  to page to a new or existing standard location.

**NOTE:** You can go to a specific standard by holding down the Enter key  $\leftarrow$  until the Enter Std Number menu appears, and selecting the number through the editor. This provides a convenient method of selecting a specific standard when many standards exist in the database.

**Entering Standard Data**

Depending on how data was input, the standard entry field displays as Measured, Manual, or Downloaded. Measured appears when the instrument was used to measure the sample. Manual displays when data values are manually entered into the instrument using the alphanumeric editor. Download indicates that the standard data was downloaded to the instrument from an X-Rite software program, such as X-RiteColor® Master (SP62 and SP64 only).

**To access the standard entry menu:**

1. Use the Tab keys  $\uparrow\downarrow$  to highlight **Std Entry**.

```

Edit Standard : 1
Std Entry: Empty
Std Name :
Tolerances...
Shade Sort Opts...
Std Lock : Unlocked
    
```

2. Press the Enter key  $\leftarrow$  to access the Standard Entry menu.

```

Measure Std : 1
<Measure Standard>
L*a*b*      L*  0.00
065/10      a*  +0.00
SPIN        b*  +0.00
..*..*..
    
```

### Measuring a Standard

1. Make sure **Measure** appears in the upper left corner of the display. If **Manual** appears, press the Enter key  $\leftarrow$  to toggle to Measure.

<b>Measure</b>	Std : 1
<Measure Standard>	
L*a*b*	L* 0.00
D65/10	a* +0.00
SPIN	b* +0.00
.....	

2. Position the instrument on the standard and take the reading. Release the instrument when Measurement Done is displayed.

Color data parameters

<b>Measure</b>	Std : 1
<Measurement Done>	
L*a*b*	L* 23.30
D65/10	a* -0.25
SPIN	b* -28.03
.....	<b>SAVE</b>

3. Retake the measurement if necessary, or press the Enter key  $\leftarrow$  with **Save** highlighted to store measurement. The screen automatically advances to the next “empty” standard.
4. Continue with additional measurements.

### Locked Standards

When attempting to measure a sample with a locked standard selected, a Standard Locked: Create New Standard? message appears. Select **Yes** if you want to create a new standard and press the Enter key  $\leftarrow$ . The standard must be unlocked if you want to overwrite the existing data. *Refer to Unlocking/Locking Standards later in this section.*

### Manually Entering Color Data

1. Make sure **Manual** appears in the upper left corner of the display. If **Measure** appears, press the Enter key  $\leftarrow$  to toggle to Manual.
2. Use the Tab keys  $\uparrow \downarrow$  to highlight the color space parameter. Press the Enter key  $\leftarrow$  to select the desired color space.

Color space  
Illum/Obs  
Specular Component

<b>Manual</b>	Std : 1
<Enter Color Data>	
XYZ	X 0.00
A/2	Y 0.00
SPIN	Z 0.00
Next	<b>SAVE</b>

Color space attributes



3. Use the Tab keys  $\uparrow\downarrow$  to highlight the illum/obs parameter. Press the Enter key  $\leftarrow$  to select the desired illum/obs.
4. Use the Tab keys  $\uparrow\downarrow$  to highlight the specular component parameter. Press the Enter key  $\leftarrow$  to toggle between specular included and specular excluded.
5. Use the Tab keys  $\uparrow\downarrow$  to highlight the desired color space attribute. Press the Enter key  $\leftarrow$  to open Edit Color Data menu.



6. Use the Tab keys  $\uparrow\downarrow$  to choose the desired digit (arrows above and below designate the selection). Press the Enter key  $\leftarrow$  to access the alphanumeric editor.
  - NOTE: Positioning the arrows above and below  $\uparrow$  or  $\downarrow$  and pressing the Enter key  $\leftarrow$  toggles between the two symbols.
7. Use the Tab keys  $\uparrow\downarrow$  to highlight the desired number and press the Enter  $\leftarrow$  key to exit editor.
8. Continue with additional digit edits if required.
9. When editing is completed, use the Tab keys  $\uparrow\downarrow$  to highlight **Save & Exit** and press the Enter  $\leftarrow$  key.
10. Continue with additional attribute editing for the selected color space.
11. When all attributes have been edited for the selected color space, highlight **Save** and press the Enter key  $\leftarrow$ .
12. If additional color space editing is required, repeat Steps 2 through 11. Up to 10 manual settings can be defined for each standard.

NOTE: Highlighting **Next** and continually pressing the Enter key  $\leftarrow$  pages through the color space data that you have set.

## Entering Standard Name

The standard name can consist of up to 20 characters, with the first 10 displaying on the View Standard menu. The name is entered using the alphanumeric editor.

**To access standard name menu:**

1. Use the Tab keys  $\uparrow\downarrow$  to highlight **Std Name**.

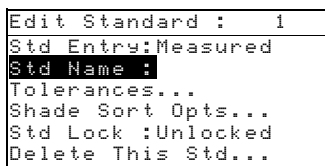

2. Press the Enter key  $\leftarrow$  to access the Edit Standard Name menu.

**NOTE:** To quickly remove a name, highlighting **CLEAR** and press the Enter key  $\leftarrow$ .

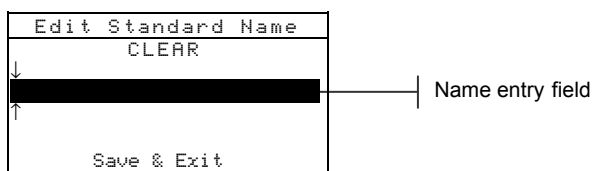

3. Use the Tab keys  $\uparrow\downarrow$  to highlight the name entry field.
4. Use the Tab keys  $\uparrow\downarrow$  to choose the desired character location (arrows above and below designate the selection). Press the Enter key  $\leftarrow$  to access the alphanumeric editor.
5. Press the Enter key  $\leftarrow$  again to quickly page through groups of letters, symbols, and numbers.
6. Use the Tab keys  $\uparrow\downarrow$  to highlight the desired character and press the Enter  $\leftarrow$  key to exit editor.
7. Continue with additional character edits.
8. When editing is completed, use the Tab keys  $\uparrow\downarrow$  to highlight **Save & Exit** and press the Enter  $\leftarrow$  key.

**Setting Tolerance Limits**

The tolerance limit is the maximum allowable difference from the standard color values that is considered acceptable. The tolerances are used to test your sample's acceptability by displaying a pass or fail signal, based on the entered limits. The plus and minus limits can be set equal or individually for  $L^*a^*b^*$ ,  $L^*C^*h^\circ$ , and  $L^*u^*v^*$ . Pass/fail indication appears in QA and Strength modes when set.

**To access tolerance entry menu:**

1. Use the Tab keys  $\uparrow\downarrow$  to highlight **Tolerances...**

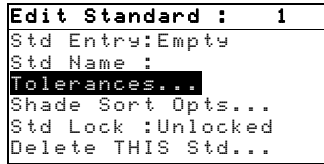

2. Press the Enter key  $\leftarrow$  to access the tolerance entry menu.

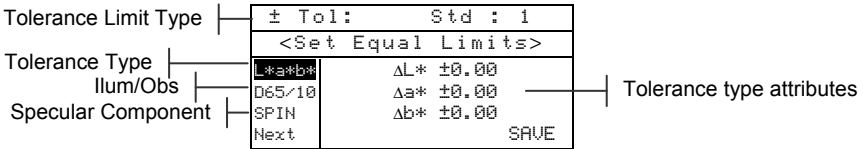

3. Use the Tab keys  $\uparrow\downarrow$  to highlight the Tolerance type. Press the Enter key  $\leftarrow$  to select the desired type.
4. If entering different plus and minus values for  $L^*a^*b^*$ ,  $L^*C^*h^\circ$ , etc., use the Tab keys  $\uparrow\downarrow$  to highlight the plus/minus symbol in the upper left of the display. Press the Enter key  $\leftarrow$  to page through  $\pm$ , +, or - limit type.
5. Use the Tab keys  $\uparrow\downarrow$  to highlight the illum/obs parameter. Press the Enter key  $\leftarrow$  to select desired illum/obs.
6. Use the Tab keys  $\uparrow\downarrow$  to highlight the specular component parameter. Press the Enter key  $\leftarrow$  to toggle between specular included and specular excluded.
7. Use the Tab keys  $\uparrow\downarrow$  to highlight the desired tolerance type attribute. Press the Enter key  $\leftarrow$  to open Enter Symmetric Tol menu.

**NOTE:** Depending on Limit Type selection, Plus or Minus could appear in place of Symmetric.

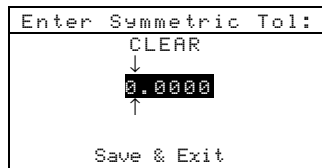

**NOTE:** "Standard cannot be changed" appears in the display when attempting to edit attributes with the standard locked. Refer to Locking/Unlocking Standard later in this section for additional information. Press the Enter key  $\leftarrow$  to clear the message.

8. Use the Tab keys  $\updownarrow$  to choose the desired digit (arrows above and below designate selection). Press the Enter key  $\leftarrow$  to access the alphanumeric editor.
9. Use the Tab keys  $\updownarrow$  to highlight the desired number and press the Enter  $\leftarrow$  key to exit the editor.
10. Continue with additional digit edits if required.
11. When editing is completed, use the Tab keys  $\updownarrow$  to highlight **Save & Exit** and press the Enter  $\leftarrow$  key.
12. Continue with additional attribute editing for the selected tolerance type.
13. When all attributes have been edited for the selected tolerance type, highlight **Save** and press the Enter key  $\leftarrow$ .
14. If additional tolerance type editing is required, repeat Steps 2 through 13.

**NOTE:** Highlighting **Next** and continually pressing the Enter key  $\leftarrow$  pages through the tolerances that you have set.

### Setting Shade Sort Options

**NOTE:** The Shade Sort option does not appear for a standard with manually entered data.

The shade sort size is based on the dimensions placed on the color space attributes. The value represents a three-dimensional box in space. These boxes are layered nine deep on each axis and at the center is the 555 reference box. This box represents your reference color. The value in the L\*, a\*, and b\* fields determine the reference box size. A smaller value is entered for a tighter tolerance. Values range from .01 to 9.99

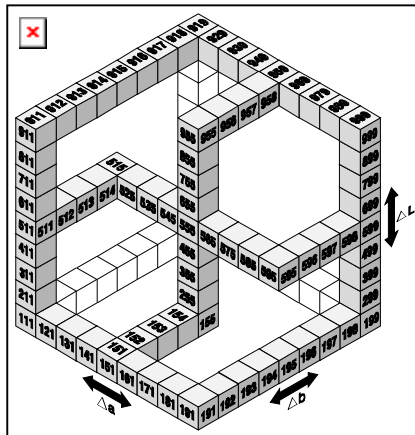

The shade sort range determines the range of the 555 shade tag boxes to be used and displayed. The range can be set from 1 to 9 in the three dimensional space.

The 555 indication appears on the QA mode when set.

**NOTE:** The Shade Sort options cannot be edited if the standard is locked. Refer to Locking/Unlocking Standard later in this section for additional information

**To access the shade sort options menu:**

1. Use the Tab keys  $\updownarrow$  to highlight **Shade Sort Opts...**.

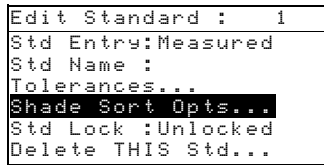

2. Press the Enter key  $\leftarrow$  to access the size/range setup menu.

**Shade Sort Size Editing**

1. Make sure **Size** appears in the upper left corner of the display. If **Range** appears, press the Enter key  $\leftarrow$  to toggle to Size.

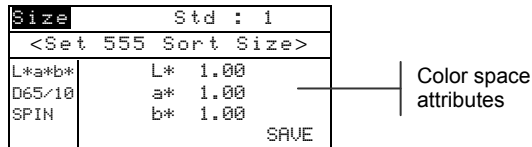

2. Select the desired color space, illum/obs, and specular component.
3. Use the Tab keys  $\updownarrow$  to highlight the desired color space attribute. Press the Enter key  $\leftarrow$  to open the Edit Sort Size menu.

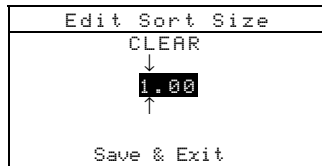

4. Use the Tab keys  $\updownarrow$  to choose the desired digit (arrows above and below designate the selection). Press the Enter key  $\leftarrow$  to access the alphanumeric editor.
5. Use the Tab keys  $\updownarrow$  to highlight the desired number and press the Enter  $\leftarrow$  key to exit the editor.

6. Continue with additional digit edits if required.
7. When editing is completed, use the Tab keys  $\uparrow\downarrow$  to highlight **Save & Exit** and press the Enter  $\leftarrow$  key.
8. Continue with additional attribute editing for the selected color space.
9. When all attributes have been edited for the selected color space, highlight **Save** and press the Enter key  $\leftarrow$ .

### Shade Sort Range Editing

1. Make sure **Range** appears in the upper left corner of the display. If **Size** appears, press the Enter key  $\leftarrow$  to toggle to Range.

<b>Range</b>	Std : 1	
<Set 555 Sort Range>		
L*a*b*	L* 1 to 9	Sort range components
D65/10	a* 1 to 9	
SPIN	b* 1 to 9	
		SAVE

2. Select the desired color space, illum/obs, and specular component.
3. Use the Tab keys  $\uparrow\downarrow$  to highlight the desired lower or upper sort range component.
4. Repeatedly press the Enter key  $\leftarrow$  to select the desired range value.
5. Continue with additional component editing.
6. When all components have been edited, highlight **Save** and press the Enter key  $\leftarrow$ .

### Locking/Unlocking Standard

All measured and manually entered standards are initially set as locked. A locked standard cannot be deleted or edited. The “locked” status of the standard can be changed whenever desired. Downloaded standards cannot be unlocked.

#### To change the locked status of a standard:

1. Use the Tab keys  $\uparrow\downarrow$  to highlight **Std Lock**.

Edit Standard : 1
Std Entry: Measured
Std Name :
Tolerances...
Shade Sort Opts...
<b>Std Lock : Unlocked</b>
Delete THIS std...

2. Press the Enter key ↵ to toggle between Locked and Unlocked. The “Delete THIS std” option only appears for an unlocked standard.

## Deleting the Standard

This option deletes the current standard selected. While the standard number remains, all related data is deleted. You can then use the location to add a new standard.

### To delete the current standard:

1. Use the Tab keys ⇄ to highlight **Delete THIS Std...**.

```

Edit Standard : 1
Std Entry: Measured
Std Name :
Tolerances...
Shade Sort Opts...
Std Lock : Unlocked
Delete THIS std...
```

2. Press the Enter key ↵ to delete the current standard.

## Projects Mode

The projects mode is used to access the View Project menu. From this menu, project names and standard links can be created and edited and new projects added.

A project maintains a group of standards from which the instrument selects the closest color for comparison of measured samples.

Projects help you organize your standards. For example, a project can represent a customer that has several standard colors for a particular product line.

### To open the View Project menu:

- Repeatedly press the Tab Down ↓ key to highlight **Projects**. Press the Enter key ↵ to access the View Project Menu.

```

-MAIN MENU-
  ↑
Calibrate      X-Rite
Standards      SP62
Projects     -----
Run Job        XXXX
Configurati    *****
  
```

## Selecting Project Number

The project number is used to page to a specific project location if more than one project exists in the database.

### To access a new or existing project location:

- Use the Tab keys ⇅ to highlight the project # in the View Project field.

```

View Project : 1
Proj Standards
Proj Name:
Proj Lock: Unlocked
Add New Project
Delete This Project
  
```

| Current project location

- Press the Enter key ↵ to page to the project location. One is the only location that can be selected when no projects exist in the database.

**NOTE:** You can go to a specific project by holding down the Enter key ↵ until the Enter Proj Number menu appears, and selecting the number through the editor. This provides a convenient method of selecting a specific project when many projects exist in the database.



## Assigning Standards to a Project

The project standard field is used to assign standards that exist in the database to the selected project. Standards can be shared between projects. A total of 300 standards can be assigned to one project.

### To assign standards to a project:

1. Use the Tab keys  $\updownarrow$  to highlight **Proj Standards**.

**NOTE:** If no standards are assigned to the current project, the “No stds in this project. Using all standards” message appears. Press any key to clear the message and continue with assigning standards.

```
View Project : 1
Proj Standards
Proj Name:
Proj Lock: Unlocked
Add New Project
Delete This Project
```

2. Press the Enter key  $\leftarrow$  to access the Select Standards menu.

```
Select Standards
1: Standard A
>2: Standard B
3: Standard C
>4: Standard D
5: Standard E
6: Standard F
```

Arrow indicates selected standard

3. Use the Tab keys  $\updownarrow$  to highlight the standard to assign.
4. Press the Enter key  $\leftarrow$  to toggle the standard active or inactive. The “>” indicates the standard is assigned.

**NOTE:** “Project is Locked” appears in the display when attempting to change the status of a standard when the project is locked. Refer to Locking/Unlocking Projects later in this section for additional information. Press the Enter key  $\leftarrow$  to clear this if it occurs.

5. Continue with additional standard selections.
6. After selections are complete, press the Escape key  $\backslash$  to save and exit.

## Entering Project Name

The project name can consist of up to 20 characters with the first 10 displaying in the View Project menu. The name is entered using the alphanumeric editor.

### To access project name menu:

1. Use the Tab keys  $\updownarrow$  to highlight **Proj Name**.

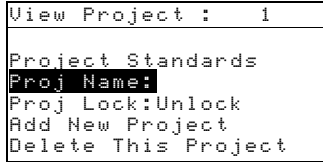

2. Press the Enter key  $\leftarrow$  to access the Edit Project Name menu.

**NOTE:** "Project is Locked" appears in the display when attempting to enter name with the project locked. Refer to Locking/Unlocking a Project later in this section for additional information. Press the Enter key  $\leftarrow$  to clear message.

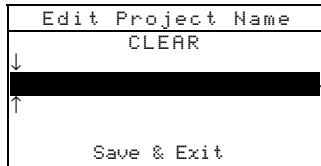

3. Use the Tab keys  $\updownarrow$  to highlight the name entry field.
4. Use the Tab keys  $\updownarrow$  to choose the desired character location (arrows above and below designate selection). Press the Enter key  $\leftarrow$  to access the alphanumeric editor.
5. Press the Enter key  $\leftarrow$  again to quickly page through groups of letters, symbols, and numbers.

**NOTE:** If editing a name, highlighting **CLEAR** and pressing the Enter key  $\leftarrow$  will quickly clear the name field.

6. Use the Tab keys  $\updownarrow$  to highlight the desired character and press the Enter  $\leftarrow$  key to exit the editor.
7. Continue with additional character edits.
8. When editing is completed, use the Tab keys  $\updownarrow$  to highlight **Save & Exit** and press the Enter  $\leftarrow$  key.

## Locking/Unlocking Project

A locked project cannot be edited. The “locked” status of the project can be changed whenever desired.

### To change the locked status of a project:

1. Use the Tab keys  $\updownarrow$  to highlight **Proj Lock**.

```
View Project : 1
Proj Standards
Proj Name:
Proj Lock:Unlocked
Add New Project
Delete This Project
```

2. Press the Enter key  $\leftarrow$  to toggle between Locked and Unlocked.

## Add New Project

The “Add New Project” item adds a new project to the database.

### To add a new project:

1. Use the Tab keys  $\updownarrow$  to highlight **Add New Project**.

```
View Project : 1
Proj Standards
Proj Name:
Proj Lock:Unlocked
Add New Project
Delete This Project
```

2. Press the Enter key  $\leftarrow$  to open the Add New Project menu.
3. Add a new project? appears. Use the Tab keys  $\updownarrow$  to highlight **Yes** and press the Enter key  $\leftarrow$ . A new project number is added to the View Project field.

## Deleting the Project

This option deletes the current project selected and samples. Standards that are assigned to the project are not deleted.

### To delete the current project:

1. Use the Tab keys  $\updownarrow$  to highlight **Delete This Project**.

```
View Project : 1
Proj Standards
Proj Name:
Proj Lock:Unlocked
Add New Project
Delete This Project
```

2. Press the Enter key  $\leftarrow$  to delete the current project.

## QA Mode

The QA measurement mode can be used in conjunction with a quality assurance software package, such as X-Rite's X-RiteColor® Master (SP62 and SP64 only). Sample measurements are compared to stored standards and the results displayed. Stored measurement data can then be uploaded to the software program for further analysis. The measurement results displayed depend on how the instrument configuration is set. Measurement results can display as measured or color difference compared to a standard. Difference data can have pass/fail tolerancing applied along with 555 shade sort. This section covers all the functions available in the QA mode.

### To access the QA mode:

1. Use the Tab keys  $\uparrow$  to highlight **QA**.

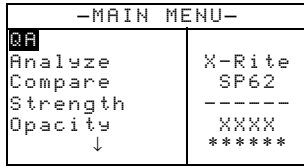

2. Press the Enter key  $\leftarrow$  to access the QA mode.

Project Location | Proj 1: PROJECT A | Project Name

Standard Location | Std 1: STANDARD A | Standard Name

Accesses | Sample: <Last Meas> | This field always displays <Last Meas> when samples are not stored. When samples are stored, a sample # and time stamp is displayed.

Sample Tools | L\*a\*b\* | ΔL\* +0.05

065/10 | L\* 88.25 | Δa\* -0.03

SPIN | a\* -4.71 | Δb\* -0.14

..... | b\*+36.64 | ΔE\* 0.16

This area displays sample measured values. Pass/Fail and 555 Shade Sort indication appears here when they are activated.

Sample difference values or words appear indicating color direction compared to the current standard.

## Selecting a Project

The instrument defaults to Proj 1 until a project is downloaded (SP62 and SP64 only) or manually entered. When using multiple projects, you must select the correct location before measuring a sample. The auto standard function does not recognize standards across multiple projects.

### To select a project:

1. Use the Tab keys  $\uparrow\downarrow$  to highlight **Proj #**.

Proj 1:	PROJECT A
Std 1:	STANDARD A
Sample:	<Empty>
L*a*b*	
D65/10	
SPIN	
.....	

2. Continually press the Enter key  $\leftarrow$  to page through the available projects, or hold down the Enter key  $\leftarrow$  and select a specific project from the editor.

**NOTE:** Highlighting the project name and pressing the Enter key  $\leftarrow$  accesses the View Project menu. Refer to *Projects Mode* covered earlier in this section for information on this mode.

## Selecting a Standard

A standard must be manually selected when the Auto Std option is turned off in the configuration menu. Only standards assigned to the selected project appear in this field. If no projects are used, any standard in the database can be selected.

### To select a standard:

1. Use the Tab keys  $\uparrow\downarrow$  to highlight **Std #**.

Proj 1:	PROJECT A
Std 1:	STANDARD A
Sample:	<Empty>
L*a*b*	
D65/10	
SPIN	
.....	

2. Continually press the Enter key  $\leftarrow$  to page through the available standards, or hold down the Enter key  $\leftarrow$  and select a specific standard from the editor. A “flag” icon appears next to standards that have manually entered data.

**NOTE:** Highlighting the standard name and pressing the Enter key  $\leftarrow$  accesses the View Standard menu. Standard information can only be viewed from this menu. Refer to *Standards Mode* covered earlier in this section for information on this mode.

## Pass/Fail Operation

The Pass/Fail function displays PASS or FAIL for a sample on the instrument screen, based on the tolerances assigned to the standard. A “green” or “red” light also illuminates, indicating the sample’s acceptability. The Pass/Fail option must be activated in the Instrument Configuration and tolerances set for the standard.

### To perform a pass/fail measurement:

1. Select project location (if used) as discussed earlier.
2. Select the standard location if the auto standard selection is not activated in configuration. Measure the sample.

Acceptance indication (pass or fail)	Proj 1: PROJECT A			Time stamp for stored sample
	Std 2: STANDARD B			
	Sample: #1 11:28			
	L*a*b*	<b>PASS</b>	$\Delta L^*$ +0.35	
	D65/10		$\Delta a^*$ -0.15	
SPIN	$\Delta b^*$ +0.15			
.....	$\Delta E$ 0.41			

## 555 Shade Sort Operation

The 555 Shade Sort function displays a three-digit number for the sample on the instrument screen, based on the shade size and shade range. Pass/Fail operation can also be used in conjunction with Shade Sort if required. The Shade Sort option must be activated in the Instrument Configuration and the size and range set for the standard.

### To perform a shade sort measurement:

1. Select the project location (if used) as discussed earlier.
2. Select standard location if the auto standard selection is not activated in the configuration. Measure the sample.

Acceptance indication with shade tag	Proj 1: PROJECT A			Time stamp for stored sample
	Std 2: STANDARD B			
	Sample: #1 11:28			
	L*a*b*	<b>PASS</b> <b>565</b>	$\Delta L^*$ +0.35	
	D65/10		$\Delta a^*$ -0.15	
SPIN	$\Delta b^*$ +0.15			
.....	$\Delta E$ 0.41			

### Shade Sort Out of Range Indication

If an up arrow or a down arrow appears in the place of a shade sort number, this indicates that the number is out of range. The way the arrow is pointing indicates the failure direction. An up arrow indicates above and a down arrow indicates below.

	Proj 1: PROJECT A	
	Std 2: STANDARD B	
	Sample: #2 11:35	
Failure indication and direction	L*a*b*	FAIL ΔL* -17.36
	D65/10	Δa* +4.24
	SPIN	Δb* +30.16
	.....	ΔE 35.05
		↑6↓

### Display Difference Indication

The instrument can display color differences numerically (default setting) or as a verbal description, depending on the setting of the Difference Display option in Configuration. When delta words are used, the “L\*” attribute for L\*a\*b\* or L\*C\*H\* displays as “Lighter” or “Darker” from the standard. The “a\*” and “b\*” attributes for L\*a\*b\* and the “H\*” (hue) attribute for L\*C\*H\* display as “>>Red”, “>>Grn”, “>>Blu”, or “>>Yel.” This is an indication of what color direction the attribute is towards. For L\*C\*H\*, the “C\*” (chroma) attribute will display as “Brighter” or “Duller.” Words only appear for L\*a\*b\*, L\*C\*h°, and Lab (Hunter) color space selections.

Words will not display for an attribute that is less than 1/7<sup>th</sup> of the ΔE value. A value less than this amount is considered insignificant compared to the total difference.

If the delta value for any attribute is greater than “10.00”, the display changes to numeric values.

The Difference Display option must be set to “Words” in the Instrument Configuration.

	Proj 1: PROJECT A	
	Std 2: STANDARD B	
	Sample: #3 12:05	
Direction of color difference	L*a*b*	PASS Darker
	D65/10	>> Red
	SPIN	>> Yel
	.....	ΔE 0.86

## Storage Operation

When the storage function is activated in the instrument configuration, sample measurements are saved to the database with a number and a time stamp. The instrument provides a large amount of RAM for storing samples and standards. A combined total of more than 3,000 can be stored in the database.

### To view stored measurements:

1. Select the project location (if used) as discussed earlier.
2. Use the Tab keys  $\uparrow\downarrow$  to highlight the sample number and time stamp.
3. Continually press the Enter  $\leftarrow$  key to page through stored samples, or hold down the Enter key  $\leftarrow$  and select a specific sample from the editor. *To delete or transmit the stored sample, refer to Sample Tools.*

Proj 1: PROJECT A		
Std 1: STANDARD A		
Sample: #9 9:51		
L*a*b*		$\Delta L^*$ +0.05
D65/10	L* 88.25	$\Delta a^*$ -0.03
SPIN	a* -4.71	$\Delta b^*$ -0.14
..:..	b*+36.64	$\Delta E^*$ 0.16

Sample number  
and time stamp

**NOTE:** Sample numbers may not appear in a consecutive order if multiple projects are used. The instrument numbers the samples in the order that they are measured, and only samples associated with the current project are displayed.

## Measurement Averaging

When the averaging function is activated, all modes (except calibration) require multiple measurements per sample. The number of measurements is set in the instrument configuration. Measurements are typically taken at various locations on a sample to achieve average data values. Averaging should be used when measuring non-uniform samples, textured materials, and any dark or high chroma colors.

### To perform an averaging measurement sequence:

1. Select project location (if used) as discussed earlier.
2. Select the standard location if the auto standard selection is not activated in configuration.
3. Position the instrument on the first area of the sample and take measurement. Sample data appears when the



instrument is held down and averaged data appears when the instrument is lifted.

**NOTE:** Pressing the Escape key **⌘** during averaging aborts the sequence and removes all measurements averaged to that point.

Proj 1: PROJECT A		
Std 2: STANDARD B		
Average: 1 of 3		
L*a*b*		ΔL* +0.35
D65/10	L* 94.10	Δa* -0.15
SPIN	a* +0.91	Δb* +0.15
.....	b* -3.59	ΔE 0.41

Indicates the first measurement of three required

- Continue with additional measurements as required to fulfill averaging sequence.

### Sample Database Tools

The Sample Database Tools menu allows you to transmit data to a computer or printer and delete stored sample data. If the storage feature is not used, only the current sample can be transmitted from this menu.

**To access the tools menu:**

- Select the project location (if used) and store sample as discussed earlier.
- Use the Tab keys **⇧** to highlight **Sample**.

Proj 1: PROJECT A		
Std 1: STANDARD A		
Sample: #9 9:51		
L*a*b*		ΔL* +0.05
D65/10	L* 88.25	Δa* -0.03
SPIN	a* -4.71	Δb* -0.14
.....	b* +36.64	ΔE* 0.16

- Press the Enter **↵** key to open the Tools menu.

Tools - Sample 9	
Transmit This Sample	
Transmit Proj Sample	
Transmit All Samples	
Delete This Sample	
Delete Proj Samples	
Delete All Samples	

Selected sample

#### Transmit This Sample

Transmits the current sample data out the serial port.

#### Transmit Proj Sample

Transmits all samples that exist in the current project.

#### Transmit All Samples

Transmits all samples stored in the instrument.

**Delete This Sample**

Deletes the current sample from the database.

**Delete Proj Samples**

Deletes all samples attached to the current project.

**Delete All Samples**

Deletes all samples stored in the database.

4. Use the Tab keys  $\updownarrow$  to highlight the desired tools option and press the Enter key  $\leftarrow$ .
5. Use the Tab keys  $\updownarrow$  to highlight Yes and press the Enter key  $\leftarrow$  to initiate the selected tools option.

**Viewing the Reflectance Graph**

The instrument can display reflectance graphs for the standard and sample at the same time. Reflectance values (actual or difference) are displayed in 10nm increments, from 400 to 700 nanometers. Reference data can also be viewed with specular included or excluded.

Measurements can be taken with the reflectance graph displayed in Analyze and Compare mode.

**NOTE:** The reflectance graph is auto scaling and could change when switching between SPIN and SPEX components.

**To view a reflectance graph:**

1. Use the Tab keys  $\updownarrow$  to highlight the reflectance curve.

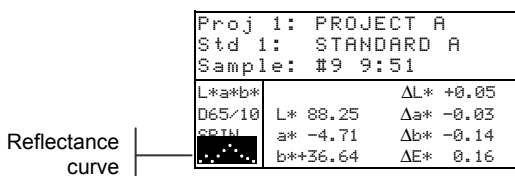

2. Press the Enter key  $\leftarrow$  to display the reflectance graph.

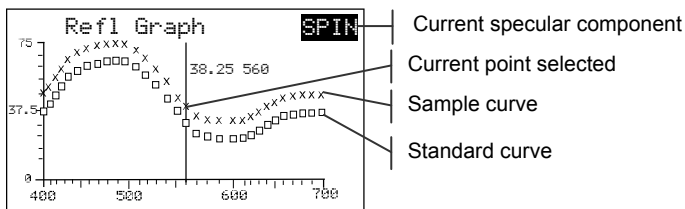

**NOTE:** When averaging is used, all measurements must be completed before the graph screen can be entered.

3. Pressing the Enter key  $\leftarrow$  with the specular component highlighted toggles between **SPIN** and **SPEX**. The curve automatically adjusts between selections.
4. Repeatedly press the Tab Up key  $\uparrow$  or Tab Down key  $\downarrow$  to view data in 10nm increments, along the reflectance curve.
5. Pressing the Enter key  $\leftarrow$  when a reflectance point is selected toggles the graph between actual sample data and difference data.

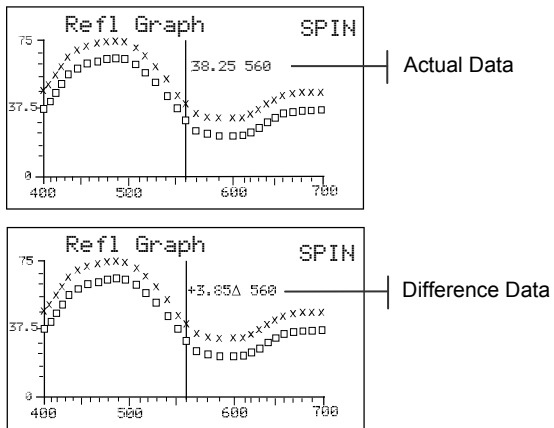

6. Press the Escape key  $\uparrow$  to return the display to the main data screen.

## Strength Mode

The Strength mode calculates the color strength of the measured sample compared to the current standard. Strength is calculated using the method selected in the instrument configuration (Apparent, Chromatic, or Tristimulus). Once measured, the color data can be calculated and displayed for color at equivalent strength (@ 100%). The strength to achieve minimum Delta E\* can also be calculated and displayed.

Several operations available in Strength mode are identical to those available in QA Mode. Therefore, the discussion of these operations is not repeated for Strength Mode. For information covering Project Selection, Standard Selection, Storage Operation, Tagging Operation, Pass/Fail Operation, Sample Tools, and Viewing the Reflectance Graph, refer to QA Mode.

### To access the Strength mode:

1. Use the Tab keys  $\uparrow\downarrow$  to highlight **Strength**.

-MAIN MENU-	
QA	
Analyze	X-Rite
Compare	SP62
<b>Strength</b>	-----
Opacity	XXXX
↓	*****

2. Press the Enter key  $\leftarrow$  to access the Strength mode.

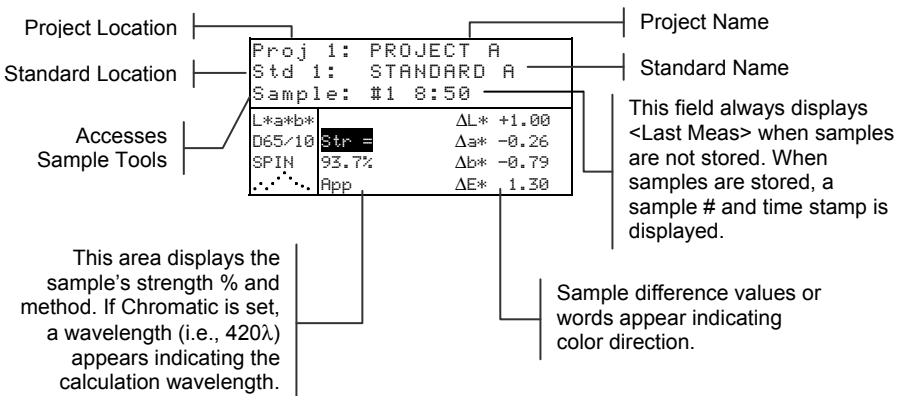

## Strength Measurement

The Strength mode displays the color strength of the measured sample. Difference data from the standard is also displayed if difference is activated in configuration. When strength is displayed for color at 100% or Strength @ Min ΔE, the difference values automatically recalculate.

### To perform a strength measurement:

1. Select project location (if used) as discussed in QA mode.
2. Select the standard location if the auto standard selection is not activated in configuration.
3. Measure the sample.
4. Use the Tab keys  $\updownarrow$  to highlight **Str =** (if not already highlighted).

Proj 1: PROJECT A		
Std 1: STANDARD A		
Sample: #1 8:50		
L*a*b*		ΔL* +1.00
D65/10	<b>Str =</b>	Δa* -0.26
SPIN	93.7%	Δb* -0.79
.....	App	ΔE* 1.30

5. Press the Enter key  $\leftarrow$  to toggle to equivalent strength.

**Predicted @ 100%  
Color Strength**

Proj 1: PROJECT A		
Std 1: STANDARD A		
Sample: #1 8:50		
L*a*b*		ΔL* +0.15
D65/10	<b>@ Str</b>	Δa* -0.20
SPIN	= 100%→	Δb* -0.56
.....		ΔE* 0.61

Color difference predicted values with equivalent strength (at 100%)

**Predicted @ MinΔE  
Strength**

Proj 1: PROJECT A		
Std 1: STANDARD A		
Sample: #1 8:50		
L*a*b*		ΔL* -0.73
D65/10	<b>≡ Str</b>	Δa* -0.14
SPIN	@MinΔE→	Δb* -0.30
.....	101%	ΔE* 0.30

Predicted strength to achieve minimum color values

## Opacity Mode

The Opacity mode is used for making multiple measurement calculations to determine Contrast Ratio or Percent Opacity. Each measurement requires three readings (over-black, over-white, and a measurement of the white backing). The final data can be stored and displayed either as over-white, over-black, or color at full hide (equivalent color @ 100% opacity) as determined by configuration settings.

Several operations available in Opacity mode are identical to those available in QA Mode. Therefore, the discussion of these operations is not repeated for Opacity Mode. For information covering Project Selection, Standard Selection, Storage Operation, Tagging Operation, Pass/Fail Operation, Sample Tools, and Viewing the Reflectance Graph, refer to QA Mode.

### To access the Opacity mode:

1. Use the Tab keys  $\uparrow\downarrow$  to highlight **Opacity**.

-MAIN MENU-	
QA	
Analyze	X-Rite
Compare	SP62
Strength	-----
<b>Opacity</b>	XXXX
	*****

2. Press the Enter key  $\leftarrow$  to access the Opacity mode.

Project Location	Proj 1: PROJECT A		Project Name
Standard Location	Std 1: STANDARD A		Standard Name
Accesses Sample Tools	Sample: #1 8:50	<input type="checkbox"/>	This field displays <Last Meas> when samples are not stored. When samples are stored, a sample #, time stamp, and data type symbol are displayed.
	L*a*b*	$\Delta L^*$ +1.00	
	065/10 Opacity	$\Delta a^*$ -0.26	This area displays the sample's opacity % and data display type.
	SPIN 97.93%	$\Delta b^*$ -0.79	
	..... <input type="checkbox"/> @100%→	$\Delta E^*$ 1.30	
			Sample difference values or words appear indicating color direction compared to the current standard.

The opacity data type saved to the database is defined in the Configuration mode. A symbol on the sample line indicates the data display type saved (see below).

- Over Black**
- Over White**
- Color at 100%**

## Opacity Measurement

The Opacity mode displays the percent opacity of a drawn down sample on an opacity card. Color difference data is also displayed if difference is activated in the configuration.

### To perform an opacity measurement:

1. Select the project location and standard location (if required) as discussed in QA mode.
2. Close the instrument to the shoe, then release to activate the opacity measurement sequence.



3. Measure the sample over the black portion of the opacity card. Release the instrument after data is displayed.

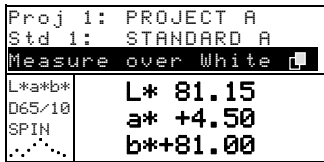

4. Measure the sample over the white portion of the opacity card. Release the instrument after data is displayed.

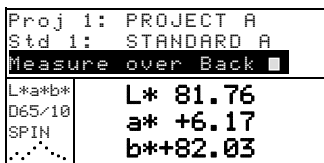

5. Measure the white backing of the opacity card. Release the instrument after the opacity value is displayed.

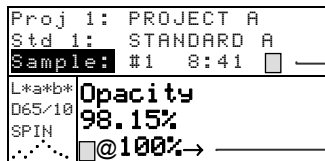

Symbol indicates color at 100% data type.

Color at 100%

■ **NOTE:** When data is stored, only one illum/obs is saved with the data.

## Analyze Mode

The Analyze mode allows you to compare sample measurements to stored standards. The resulting color data (actual and difference) is not stored in the instrument. Measured data can be automatically transmitted from the RS-232 port if Auto Xmt is activated in the Instrument Configuration.

### To access the Analyze mode:

1. Use the Tab keys  $\uparrow\downarrow$  to highlight **Analyze**.

-MAIN MENU-	
QA	
<b>Analyze</b>	X-Rite
Compare	SP62
Strength	-----
Opacity	XXXX
↓	*****

2. Press the Enter key  $\leftarrow$  to access the Analyze mode. Data from the last measurement taken is displayed.

Analyze	
Std 1:	STANDARD A
L*a*b*	$\Delta L^*$ -0.06
D65/10	L* 33.85 $\Delta a^*$ -0.02
SPIN	a* +5.55 $\Delta b^*$ +0.16
.....	b* +9.77 $\Delta E^*$ 0.17

Standard Location | Standard Name | Sample measured and difference data

3. If auto standard is not activated in configuration, select the standard location by repeatedly pressing Enter key  $\leftarrow$  with **Std #** highlighted. To go to a specific standard, hold down the Enter key  $\leftarrow$  and select the standard from the editor.
4. Measure the sample.



## Compare Mode

The Compare mode is a quick method for comparing measurements without storing the data. After entering the mode, the first measurement is set as the standard and each measurement thereafter is compared to it. The standard can be remeasured whenever desired. Measured data can be automatically transmitted from the RS-232 port if Auto Xmt is activated in the Instrument Configuration.

### To access the Compare mode:

1. Use the Tab keys  $\updownarrow$  to highlight **Compare**.

-MAIN MENU-	
QA	X-Rite
Analyze	SP62
<b>Compare</b>	-----
Strength	XXXX
Opacity	*****
↓	

2. Press the Enter key  $\leftarrow$  to access the Compare mode.

Standard	Compare
<Measure Standard>	
L*a*b*	L* 0.00
D65/10	a* 0.00
SPIN	b* 0.00
.....	

Measurement instruction

3. Measure the standard to be used for comparison.

Sample	Compare
<Measure Sample>	
L*a*b*	$\Delta$ L* +0.00
D65/10	$\Delta$ a* -0.00
SPIN	$\Delta$ b* +0.00
.....	$\Delta$ E* 0.00

Measurement instruction

Difference data appears as all zeros before measuring a sample

Standard Data

4. Standard measurement data is displayed. Measure the sample or press the Enter key  $\leftarrow$  with **Sample** highlighted to toggle to **Standard**. Another standard can then be measured.

Sample	Compare
<Measure Sample>	
L*a*b*	$\Delta$ L* -0.08
D65/10	$\Delta$ a* -0.08
SPIN	$\Delta$ b* -1.08
.....	$\Delta$ E* 1.08

Difference Data

Sample Data

## Run Job Mode (SP64 only)

The Run Job function is used to select a job sequence downloaded from X-Rite's, X-RiteColor® Master software program. A typical job would display measurement prompts on the instrument screen. The instrument can store a total of 10 jobs at one time.

Refer to X-RiteColor® Master for specific information on jobs and job operation.

### To access the Run Job mode:

1. Use the Tab keys  $\updownarrow$  to highlight **Run Job**.

-MAIN MENU-	
↑	
Calibrate	X-Rite
Standards	SP64
Projects	-----
<b>Run Job</b>	XXXX
Configurati	*****

2. Press the Enter key  $\leftarrow$  to access the Pick Job mode.

Pick Job #	
1:	Job 1
<b>2:</b>	<b>Job 2</b>
3:	Job 3
4:	Job 4
5:	Job 5

| Available jobs

3. Use the Tab keys  $\updownarrow$  to highlight the desired job.
- **Note:** <Empty> appears in the display when no jobs are available.
4. Press the Enter key  $\leftarrow$  to activate job sequence.

CHAPTER FIVE

# Service and General Maintenance

Repair Information	6-1
Cleaning the Instrument	6-1
Replacing the Battery Pack	6-3

## Repair Information

The X-Rite® SP60 Series instruments are covered by a one-year limited warranty—excluding battery pack—and should be referred to factory or authorized service center for repairs within the warranty period. Attempts to make repairs within this time frame may void the warranty.

X-Rite provides a factory repair service to their customers. Because of the complexity of the circuitry, all repairs should be referred to the factory or an authorized service center (call: 1-888-826-3059).

X-Rite will repair any instrument past warranty. The customer shall pay shipping cost to the factory or authorized service center and repair cost. The instrument shall be submitted in the original carton, as a complete unaltered unit.

## Reading Lamp Replacement Information

Due to the circuit complexity and test equipment required, **the read lamp should only be replaced by X-Rite or an authorized X-Rite Service Center.**

The lamp is monitored for intensity, and failure warnings will be displayed if a problem occurs.

## Cleaning the Instrument

Your instrument requires very little maintenance to achieve years of reliable operation. However, to protect your investment and maintain reading accuracy, a few simple cleaning procedures should be performed from time to time.

## General Cleaning

The exterior of the instrument may be wiped clean with a cloth dampened in water or mild cleaner whenever required.

**NOTE:** *DO NOT* use any solvents to clean the instrument; this causes damage to the cover.

### Cleaning the Optics

The optics should be cleaned once a week in normal environments, and more often in dirty or dusty environments. Carefully lift the instrument and blow short bursts of clean, dry air into the measurement aperture. This should remove any accumulated dust in the optics area.

**WARNING:** DO NOT invert cans that use Freon as a propellant; doing so could cause damage to the optics assembly.

### Cleaning the Calibration Reference

The calibration reference consists of a ceramic disk for white calibration measurements and a trap opening for black calibration measurements.

The white ceramic disk can be cleaned periodically using a mild soap and warm water solution, thoroughly rinsed with warm water and wiped dry with a lint-free cloth. Do not use solvents or cleaners of any kind.

The black trap portion of the reference should be cleaned with clean, dry air from time to time to remove any dust or contamination. The reference can be taken apart for easy cleaning of the black trap by compressing the two locking tabs on both sides of the case with your fingers, and separating the two sections.

**NOTE:** When reassembling the black trap, make sure the trap opening is positioned over the cone in the bottom portion of the trap. The tabs will not lock correctly if assembled in the opposite direction.

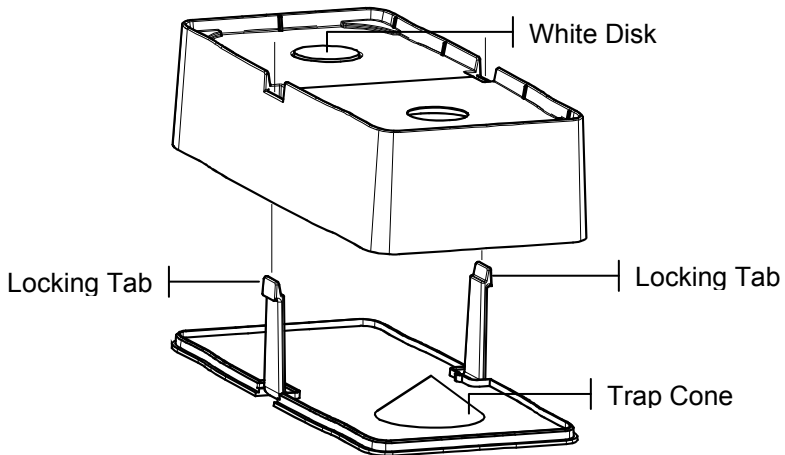

Make sure to store the calibration reference in a dry, dust free area, away from direct exposure to light.

## Replacing the Battery Pack

1. Unplug the AC adapter and click the battery switch to Off.
2. Hold the shoe next to the instrument housing and lift upward on the spring-loaded latch. Open the shoe perpendicular to the instrument housing. *Refer to Unlatching the Instrument Shoe in Section One.*
3. Carefully rotate the instrument over and rest it on its top.
4. Using your fingers, compress the two tabs located on both sides of the battery pack and remove battery pack.
5. Slide a fresh battery pack into the compartment with the battery connector facing down and to the back of the instrument.
6. Press down on the pack until the connector is properly seated and the tabs click into position.

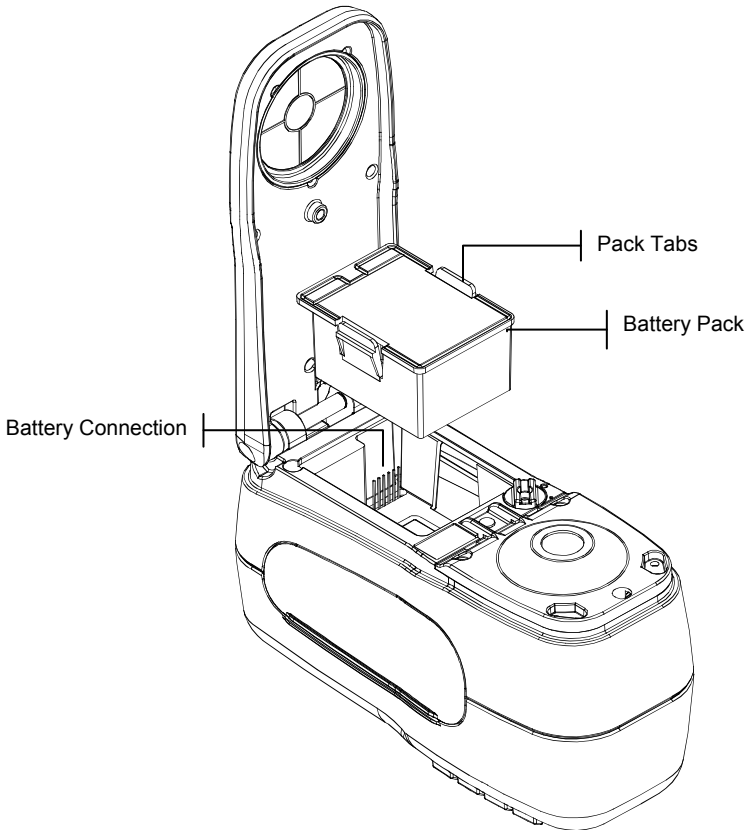

CHAPTER SIX

# Appendices

Instrument Specifications	7-1
Error Messages	7-2

## Instrument Specifications

<b>Measurement Geometrics</b>	d/8°, DRS spectral engine, choice of optical aperture: 4mm viewing/5.5mm illumination 8mm viewing/12mm illumination 16mm viewing/18mm illumination
<b>Light Source</b>	Gas-filled tungsten lamp
<b>Illuminant Types</b>	A, C, D50, D55, D65, D75, F2, F7, F11, & F12
<b>Standard Observers</b>	2° & 10°
<b>Receiver</b>	Blue-enhanced silicon photodiodes
<b>Spectral Range</b>	400nm – 700nm
<b>Spectral Interval</b>	10nm – measured, 10nm – output
<b>Storage</b>	1,024 standards with tolerances, 2,000 samples
<b>Measurement Range</b>	0 to 200% reflectance
<b>Measuring Time</b>	Approx. 2 seconds
<b>Inter-Instrument Agreement (SP60)</b>	0.40 $\Delta E^*_{ab}$ , based on avg. of 12 BCRA series II tiles 0.60 $\Delta E^*_{ab}$ max. on any tile (specular component included).
<b>Inter-Instrument Agreement (SP62V)</b>	0.30 $\Delta E^*_{ab}$ , based on avg. of 12 BCRA series II tiles 0.50 $\Delta E^*_{ab}$ max. on any tile (specular component included).
<b>Inter-Instrument Agreement (SP62)</b>	0.20 $\Delta E^*_{ab}$ , based on avg. of 12 BCRA series II tiles 0.40 $\Delta E^*_{ab}$ max. on any tile (specular component included).
<b>Inter-Instrument Agreement (SP64)</b>	0.13 $\Delta E^*_{ab}$ , based on avg. of 12 BCRA series II tiles 0.25 $\Delta E^*_{ab}$ max. on any tile (specular component included).
<b>Short-Term Repeatability (SP60 &amp; SP62V)</b>	.10 $\Delta E^*_{ab}$ max. on white ceramic, standard deviation (specular component included).
<b>Short-Term Repeatability (SP62 &amp; SP64)</b>	.05 $\Delta E^*_{ab}$ max. on white ceramic, standard deviation (specular component included).
<b>Lamp Life</b>	Approx. 500,000 measurements
<b>Power Supply</b>	Removable (Ni-metal hydride) battery pack; 7.2 VDC rated @ 1250 mAh.
<b>AC Adapter Requirements</b>	90-130VAC, 50-60Hz, 15W max
<b>Charge Time</b>	Approx. 4 hours – 100% capacity
<b>Measurements Per Charge</b>	1,000 measurements typical
<b>Data Interface</b>	Patented bi-directional RS-232, 300-57,600 baud
<b>Display</b>	128 x 256 pixel graphical LCD
<b>Operating Temperature Range</b>	50° to 104°F (10° to 40°C) 85% relative humidity maximum (non-condensing)
<b>Storage Temperature Range</b>	-4° to 122°F (-20° to 50°C)
<b>Dimensions</b>	4.3"H (10.9cm) 3.3"W (8.4cm) 7.7"L (19.6cm)
<b>Weight</b>	2.4 lbs. (1.1 kg)
<b>Accessories Provided</b>	Calibration Standard, Manual, AC Adapter, Carrying Case
<b>Usage</b>	Indoor only
<b>Altitude</b>	2000m



CHAPTER SEVEN

**Pollution Degree**

2

**Overvoltage**

Category II

X-Rite standards are traceable to National Research Council Canada, Laboratory for Basic Standards. This product covered by U.S. and foreign Patents Pending. Specifications and design subject to change without notice.

## Error Messages

Errors encountered during a measurement are displayed on the instrument screen. All errors are accompanied by a long beep and flashing yellow light. The error message is cleared from the instrument screen by pressing the Enter key **↵**.

<b>Displayed Errors:</b>	<b>Reason</b>
<b>Measurement was aborted by user</b>	Displays with an incomplete measurement or calibration. Instrument was released too soon.
<b>Calibration has timed out</b>	The calibration interval time set in the configuration has been reached. Calibration is now required.
<b>Calibration required</b>	Displays anytime the instrument requires a calibration.
<b>Calibration has failed</b>	Calibration failed. Make sure the instrument is properly positioned on the reference.
<b>The battery is getting low</b>	This warning appears when the battery falls below approximately 25% of full charge. Measurements are still possible, but the battery should be charged soon.
<b>Batteries are dead</b>	Displays when not enough battery power remains to take measurement. The current measurement is aborted.
<b>Batteries are missing</b>	The battery pack is not installed. Instrument will not allow any measurements.
<b>Incorrect Charger Voltage</b>	Wrong charger is connected or charger is bad.
<b>The battery is over-charged</b>	The battery pack is too hot. Remove the battery pack and let it cool.
<b>Lamp is getting weak, replace soon</b>	Reading lamp is at 50% strength or less from its original intensity. Measurements are still possible but the lamp should be replaced soon.

CHAPTER SEVEN



### **Corporate Headquarters**

X-Rite, Incorporated  
4300 44th Street SE  
Grand Rapids, Michigan 49512  
Phone 1 800 248 9748 or 1 616 803 2100  
Fax 1 800 292 4437 or 1 616 803 2705

### **European Headquarters**

X-Rite Europe GmbH  
Althardstrasse 70  
8105 Regensdorf  
Switzerland  
Phone (+41) 44 842 24 00  
Fax (+41) 44 842 22 22

### **Asia Pacific Headquarters**

X-Rite Asia Pacific Limited  
36th Floor, No. 169 Electric Road  
Hong Kong, China  
Phone (852)2568-6283  
Fax (852)2885 8610

Please visit [www.xrite.com](http://www.xrite.com) for a local office near you.