

X-Rite® 881/882

**Automatic Strip Reader
Color Photographic Densitometer**

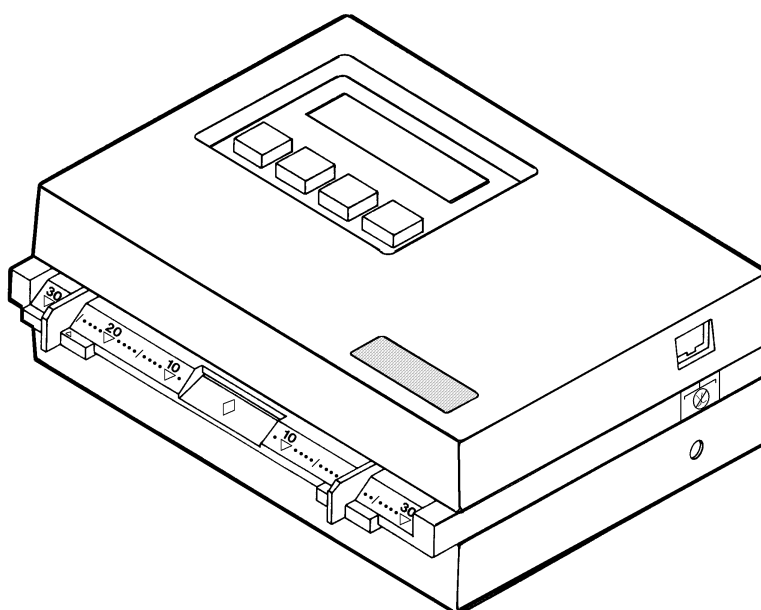

Operation Manual

CAUTION: Operational hazard exists if AC adaptor other than X-Rite SE30-61 (115V) or SE30-62 (230V) is used.

VORSICHT: Es besteht Betriebsgefahr bei der Verwendung von einem Adapter außer X-Rite SE30-61 (115 U) oder SE30-62 (230 U).

AVISO: No use otro adaptador C.A. que no sea la pieza X-Rite SE30-61 (115V) o SE30-62 (230V), por el riesgo de mal funcionamiento del equipo.

ATTENTION: Ne pas utiliser un autre adaptateur que la pièce X-Rite SE30-61 (115V) ou SE30-62 (230V).

AVVISO: Non usare un altro adattatore C.A. che non è del pezzo X-Rite X-Rite SE30-61 (115V) o SE30-62 (230V), per il rischio di malfunzionamento dell'apparecchio.

WARNING: Shielded interface cables must be used in order to maintain compliance with the desired FCC and European emission requirements.

ACHTUNG: Um das Produkt innerhalb der FCC (Vereinigten Staaten) und den europäischen Emissions-Richtlinien zu halten, müssen geschirmte Schnittstellenkabel verwendet werden.

AVISO: Para satisfacer las deseadas regulaciones de emisión para Europa y el FCC, se debe utilizar los cables de interfaz protegidos contra las interferencias electromagnéticas.

AVERTISSEMENT: On ne doit utiliser que des câbles d'interface armés avec ce produit de conformer aux règlements d'émission européens et de FCC dans les Etats-Unis.

AVVISO: Per conformare con i desiderati regolamentazioni di emissione per Europa ed il FCC, utilizzare i cavi d'interfaccia protetti contro l'interferenze elettromagnetiche.

The Manufacturer: X-Rite, Incorporated
Der Hersteller: 3100 44th Street, S.W.
El fabricante: Grandville, Michigan 49418
Le fabricant:
Il fabbricante:

Declares that: Densitometer
gibt bekannt: 881, 882
advierde que:
avertit que:
avverte che:

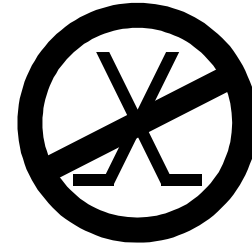

is not intended to be connected to a public telecommunications network.
an ein öffentliches Telekommunikations-Netzwerk nicht angeschlossen werden soll.
no debe ser conectado a redes de telecomunicaciones públicas.
ne doit pas être relié à un réseau de télécommunications publique.
non deve essere connesso a reti di telecomunicazioni pubblici.

FCC

This equipment has been tested and found to comply with the limits for a Class A digital device, pursuant to Part 15 of the FCC Rules. These limits are designed to provide reasonable protection against harmful interference when the equipment is operated in a commercial environment. This equipment generates, uses, and can radiate radio frequency energy and, if not installed and used in accordance with the instruction manual, may cause harmful interference to radio communications. Operation of this equipment in a residential area is likely to cause harmful interference in which case the user will be required to correct the interference at his own expense.

Canada

This Class A digital apparatus meets all requirements of the Canadian Interference-Causing Equipment Regulations.

Cet appareil numérique de la classe A respecte toutes les exigences du Règlement sur le matériel brouilleur du Canada.

DECLARATION OF CONFORMITY

complies to

EN45014:1989

Manufacturer's Name: X-Rite, Incorporated.
Manufacturer's Address: 3100 44th Street, S.W.
Grandville, Michigan 49418
U.S.A.

European Contact Name: X-Rite GmbH
European Contact Address: Stollwerckstraße 32
51149 Köln, Deutschland
(49) 2203-91450 FAX (49) 2203-914519

Model Name Densitometer
Model No. 881, 882
Year of Manufacture 1995
Directive(s) Conformance EMC 89/336/EEC LVD 73/23/EEC
Test Standards Declared EN50081-1: 1992 EN55022 Class B Radiated, Class B Conducted
EN50082-1: 1992 IEC801-2,-3,-4 and EN60950

X-Rite, Incorporated and the undersigned, hereby declare under our sole responsibility that the product to which this declaration relates, conform to the above listed Directive(s) and Standard(s).

Grandville, Michigan

4-11-96



Location

Date

Mark P. Spliedt
Product Support Engineering Manager

NOTE: The device complies to the product specifications for the Low Voltage Directive when furnished with the 230VAC AC Adapter, X-Rite P/N SE30-62.

Congratulations!

We at X-Rite, Incorporated are proud to present you with the X-Rite 881/882 Auto Strip Reading, Color Photographic Densitometer. This instrument represents the very latest in microcontrollers, integrated circuits, optics, and display technology. As a result, your X-Rite instrument is a rugged and reliable instrument whose performance and design exhibit the qualities of a finely engineered instrument, which is not surpassed.

To fully appreciate and protect your investment, we suggest that you take the necessary time to read and fully understand this manual. As always, X-Rite stands behind your instrument with a full one year limited warranty and a dedicated service organization. If the need arises, please don't hesitate to call us.

Thank you for your trust and confidence.

Chairman and CEO
Ted Thompson

Proprietary Notice

The information contained in this manual is derived from patent and proprietary data from X-Rite, Incorporated. This manual has been prepared expressly for the purpose of assisting operation and maintenance personnel in their use and general maintenance of the instrument.

Publication of this information does not imply any rights to reproduce or use it for purposes other than installing, operating, or maintaining the equipment described herein. No part of this manual may be reproduced, transcribed, stored in a retrieval system, or translated into any language or computer language, in any form or by any means: electronic, magnetic, mechanical, optical, manual, or otherwise; without the prior written permission of an authorized officer of X-Rite, Incorporated. These provisions are intended to state all of the rights and responsibilities between X-Rite, Incorporated and customer. They take place of and supersede all warranties, expressed or implied, and whether of merchantability, fitness or otherwise. The remedies contained in this operation manual are exclusive. Customer and X-Rite, Incorporated waive all other remedies, including but not limited to consequential damages.

This instrument is covered by the following U.S. and foreign patents: #4,591,978; #5,062,714; #5,118,183; and other patents pending.

Copyright © 1989 by X-Rite, Incorporated "ALL RIGHTS RESERVED"

Limited Warranty

X-Rite, Incorporated warrants each unit manufactured to be free of defects in material and workmanship for a period of twelve months. **THERE ARE NO WARRANTIES OF MERCHANTABILITY OR FITNESS. THIS WARRANTY OBLIGATION IS LIMITED TO SERVICING THE UNIT RETURNED TO X-RITE, INCORPORATED FOR THAT PURPOSE AND EXCLUDES THE LAMP.** The unit shall be returned with transportation charges prepaid. If the fault has been caused by misuse or abnormal conditions of operations, repairs will be billed at a nominal cost. In this case, an estimate will be submitted before work is started, if requested. Always include serial number in any correspondence concerning the unit. The serial number is located on the bottom of the unit.

X-Rite, Incorporated offers a repair program for instruments out of warranty. For more information, contact X-Rite Instrument Services Department.

This agreement shall be interpreted in accordance with the laws of the State of Michigan and jurisdiction and venue shall lie with the courts of Michigan as selected by X-Rite, Incorporated.

X-Rite® is a registered trademark of X-Rite, Incorporated.
Agfa-Gevaert®, Fuji®, Eastman Kodak®, Mitsubishi®, Konica®, Copal®, Noritsu® and Champion Photochemistry® are registered trademarks.
All other logos, product names, and trademarks mentioned are the property of their respective manufacturers.

Table of Contents

1. Packaging Check List	1
2. General Description	3
3. User Interface	4
4. Applying Power	6
5. Keyboard Functions	7
5.1 Strip Format Flow Chart.....	8
6. Configuring Your Instrument	9
7. Adjusting the Paper Guides	12
8. Establishing AIM Values	13
8.1 Measuring a Paper Reference Strip	13
8.2 Measuring a Film Reference Strip	15
8.3 Measuring a Printer Balance Reference Strip.....	17
8.4 Correction Factor Entry.....	19
8.5 Crossover Procedure	19
8.6 Aim Value Adjustments	20
9. Taking Measurements	21
9.1 Measuring a Color Paper Strip	23
9.2 Measuring a Film Strip	25
9.3 Measuring a Printer Balance Strip	26
10. Viewing Data	27
11. Transmitting Data	29
12. Calibration	31
12.1 Auto Calibration	32
12.2 Correlating to Another Densitometer	33
12.3 Frequency of Calibration.....	35
13. Advanced Features	36
13.1 Delete Operation	36
13.2 881/882 Network	37
14. Measuring an Internegative (882 only)	38
14.1 View	39
14.2 +Step-	40
14.3 Auto.....	40
15. Maintenance	42
15.1 Troubleshooting Chart.....	42
15.2 Optics Cleaning.....	43
15.3 Read Lamp Replacement	44
Appendix	45
A1 - Error Messages	45
A2 - Term Abbreviations	47
A3 - Unit Configuration Definition	49
A4 - Densitometer Specifications	51
A5 - Accessory Items	52

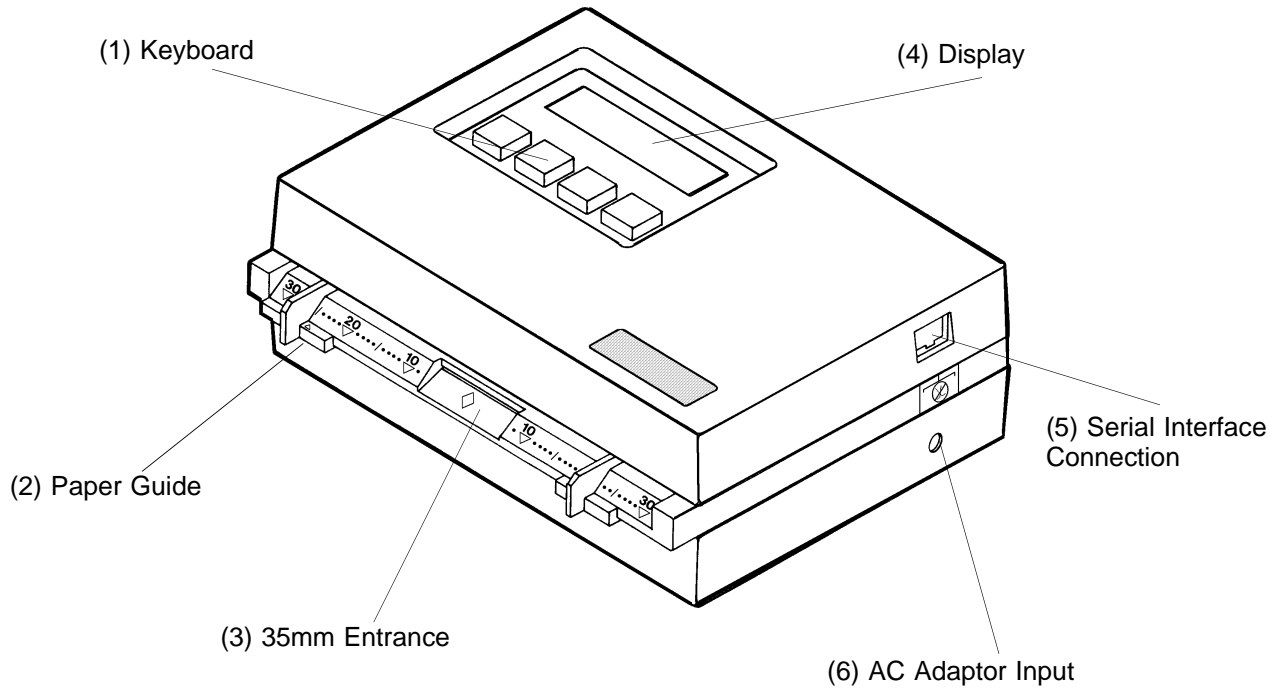

(1) KEYBOARD - Consists of four keys and is used for selecting control strip format (paper, film, & printer balance), viewing/transmitting data, and various mode functions.

(2) PAPER GUIDE - Used as an alignment guide when measuring control and reference strips.

(3) 35mm ENTRANCE - Used as an alignment guide when measuring 35mm film strips.

(4) DISPLAY - Used for displaying measurement information, messages, strip formats, etc.

(5) SERIAL INTERFACE CONNECTION - Used for sending and receiving information from a computer or printer.

(6) AC ADAPTOR - Used to power the unit.

Getting Started

This section explains the necessary steps you should first take to properly setup and use your X-Rite instrument.



Make sure that the unit is not damaged and all the accessories are enclosed, read *Packaging Check List* (Section 1).



Become familiar with the basic function of the instrument, read *General Description* (Section 2).



Become familiar with the typographical conventions, display functions, and general terms used in this manual, read *User Interface* (Section 3).



Now it's time to power up your unit, read *Applying Power* (Section 4).



Get familiar with the keyboard and operating functions, read *Keyboard Functions* (Section 5).



Set the time, date, and configuration of the densitometer (tone, I/O parameters), read *Configuring Your Instrument* (Section 6).



See how to adjust the paper guides, read *Adjusting the Paper Guides* (Section 7).



Process a reference strip and enter the AIM values into your unit, read *Establishing AIM values* (Section 8).



Process a control strip and then compare it to the AIM values, read *Taking Measurements* (Section 9).



Learn how to view the density values of the strip you just measured, read *Viewing Data* (Section 10).



Continue reading the remaining sections to find out how to transmit data, calibrate your unit, and other advance features.

1. Packaging Check List

After removing the instrument from the shipping carton, inspect for possible damage. If any damage is noted, contact the transportation company immediately. Do nothing more until the carrier's agent has inspected the damage.

If damage is not evident, check and make sure that all items are included (Refer to the parts list below, and the following page for the packaging illustration).

Your Densitometer was packaged in a specially designed carton to assure against damage. If reshipment is necessary, the instrument should be packaged in the original carton. If the original carton is not available, a new one can be obtained from X-Rite, Incorporated. Refer to the packaging drawing on the following page.

15	1	1	SD01-41	CERTIFICATE OF CALIBRATION
14	-	-	NOT USED	
13	-	-	NOT USED	
12	1	1	880-602	CONTROL STRIP & BALANCE PRINT FORMAT GUIDE
11	1	1	SD65-13	PLASTIC BAG
10	-	1	SE30-62	AC/DC ADAPTOR, 230VAC 50/60HZ
	1	-	SE30-61	AC/DC ADAPTOR, 115VAC 50/60HZ
9	-	-	NOT USED	
8	1	1	SD01-10	IMPORTANT NOTICE
7	1	1	SD01-04	WARRANTY REGISTRATION FORM
6	1	1	880-100	AUTO CALIBRATION STRIP ASSY
5	1	1	881-500	OPERATORS MANUAL
4	1	1	SD68-10	PACKAGING ENVELOPE
3	1	1	SD65-07	PLASTIC BAG
2	2	2	SD200-880-06	CARTON INSERT
1	1	1	SD200-880-01	CARTON
ITEM	QTY-881	QTY-881X	PART NUMBER	DESCRIPTION

PARTS LIST

PACKAGING ILLUSTRATION

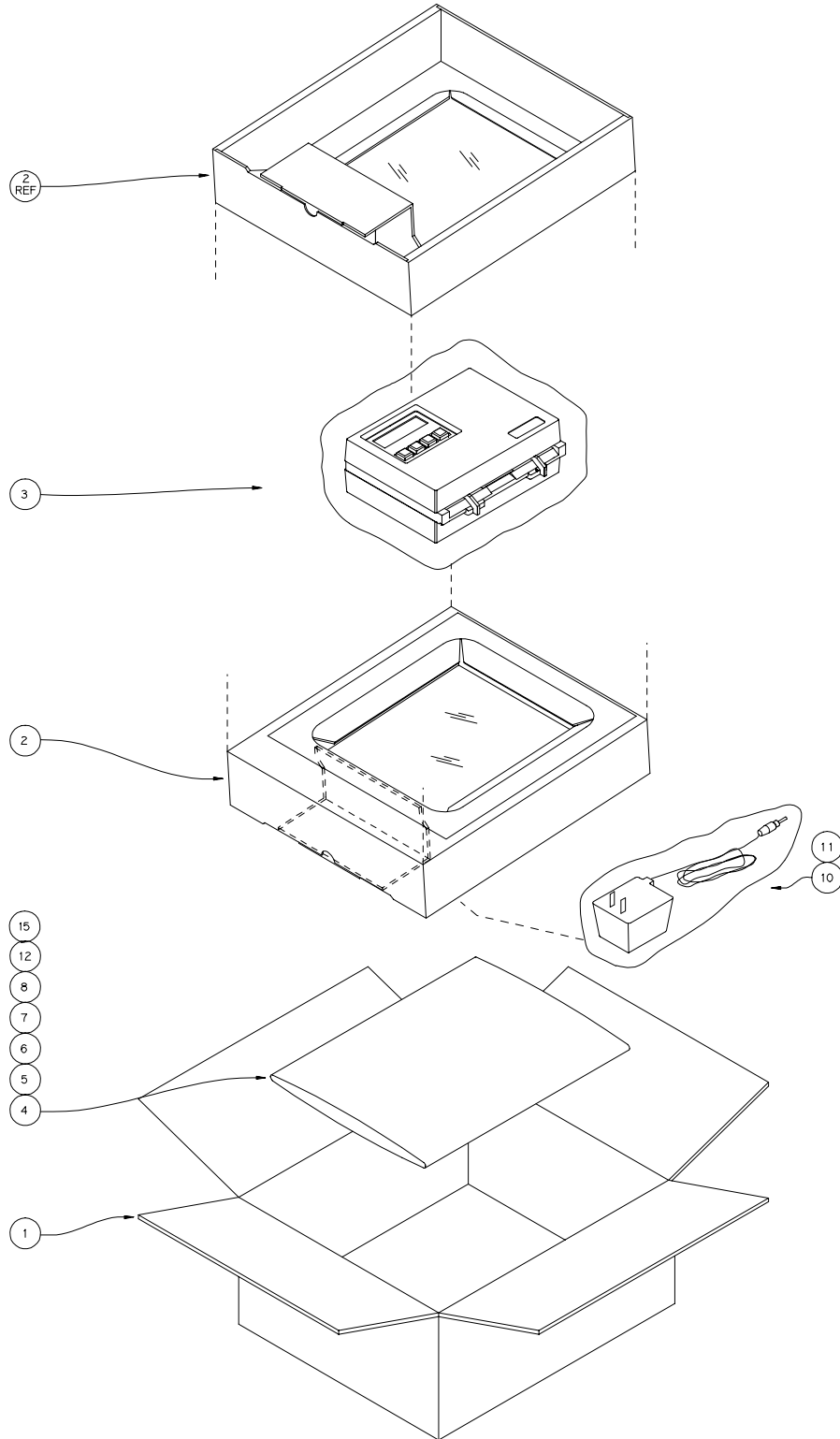

2.**General Description**

The X-Rite instrument is an automated instrument that will read film control strips, paper control strips, and printer balance strips. Simply insert strip into unit for motorized, automatic measurements.

The instrument automatically measures many types of control strips (ex., EP2, C41, RA-4, etc.), sorts the data for measured fields such as: HD, LD, & Stain; and then displays and simultaneously transmits the data to the minilab printer.

The strip formats are broken down into three **categories**:

- **Paper** (EP2, RA-4, CP-21, AP-92, R-3, P-3, etc.).
- **Film** (C-41, KBM, CN-16, etc.).
- **Printer Balance** (White Ringed Bull's-Eyes, Black Ringed Bull's-Eyes, Cropped Bull's-Eyes, etc.).

 Refer to Control Strip and Balance Print Format Guide for a complete listing of all the control strips supported by the instrument.

The instrument will output a Red, Green, and Blue density value for each field (ex., Stain, Dmax, Dmin, etc.) measured. The only requirement is that the areas to be measured on the control strip are aligned to either the left side, right side, or center line of the strip, in a straight line format.

To accommodate the different size control strips, the instrument has an adjustable paper guide on each side of the control strip entrance. Adjustment is made by simply sliding the paper guides to the settings displayed for the strip selected.

The instrument communicates using the standard RS232C interface. If it is desired to remotely control the instrument you must use the RCI (Remote Control Interface) communication protocol discussed in the 880 series RS232 Interface Manual (available from X-Rite, P/N 880-506). The RCI feature is patented by X-Rite, Incorporated.

3. User Interface

This section will familiarize you with typographical conventions, display functions, and general terms used in this manual. Also, a listing of operational information.

- In most cases **uppercase** letters in the display represent advisory information (i.e., functions, menu names, messages, warnings, etc.). The **lowercase** words and letters in the display represent key names or functions (i.e., pap, cal, yes, no, etc.), that can be modified by the keys.
- Keys that are shown as shaded will be the only keys that are active for a particular function.

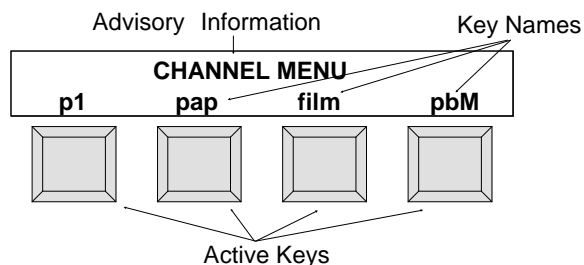

- In the text portion of this manual the instrument keys are shown with brackets on both sides and in bold face. Ex. **[pap]**, **[film]**, etc.
- Information that will appear in the display will be shown in the text with quotation marks on each side and in boldface. Ex. "**CHANNEL MENU**"
- During strip selection, a lowercase letter will be displayed next to the strip type to designate the manufacturer of the strip. They are as follows:
 - a:** (Agfa-Gevaert) **f:** (Fuji) **i:** (Ilford) **k:** (Eastman Kodak) **m:** (Mitsubishi) **cp:** (Champion Photochemistry)

Note: Konica paper control strips do not have a designation letter.

- When a particular paper strip is selected, one or both guide setting positions displayed will blink. If only one guide setting is blinking, this indicates the guide that the strip will rest on first when inserting. In most cases this only occurs on a multi pass strip. On single pass strips both settings will blink.

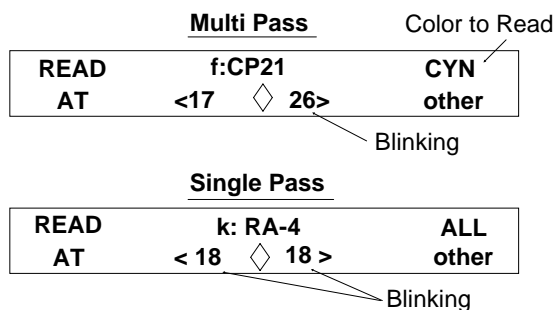

User Interface - continued

- A "hand symbol" indicates important notes and possible operations that need to be performed before normal operation.



- When a procedure is continued on the next page an "arrow symbol" will appear in the bottom right hand corner of the page.



IMPORTANT

Operational Information:

- Due to the amount of variation in printer balance strips, there are no guide settings displayed in the printer balance categories.
- When inserting strips (with 28mm or more of leader), push in until it rests against the drive rollers. For proper leaderless strip insertion, see Control Strip & Balance Print Format Guide.
- When strip is initially inserted, there is a one second delay to allow time for proper alignment.
- A 16mm wide C41 control strip can not be measured due to the drive mechanism.
- The instrument will not measure creased strips.
- If the strip gets jammed in the unit, press the two keys labeled **"MENU."** If this does not feed the strip out, pull strip out slowly from the front of unit.

4. Applying Power

To apply power to the unit, insert the adaptor plug into the unit, and then the AC line plug from the transformer into the wall socket.

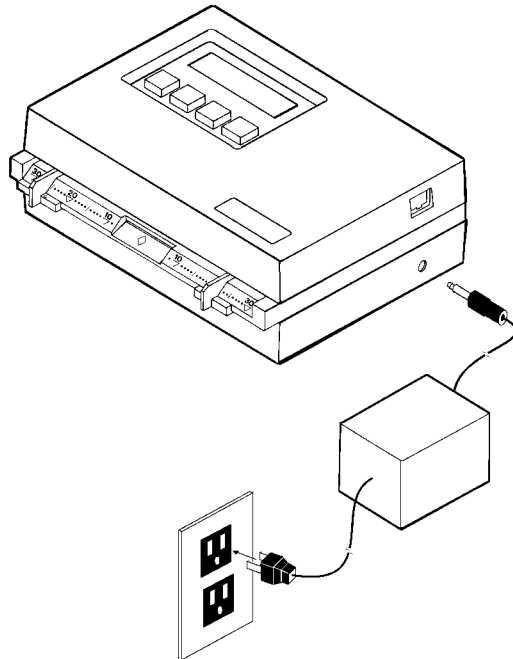

When power is applied, the instrument will perform a diagnostic procedure at initial power-up.

The CHANNEL MENU is contained in three pages and the FUNCTION MENU is contained in two pages. To advance through the pages press: **[p1]**, **[p2]**, **[p3]**, **[p4]**, **[p5]**, and **[p6]**.

If you wish to return to page 1 of the CHANNEL MENU at **any** point in time, simultaneously press the two keys marked "MENU."

IMPORTANT! To extend the life of the internal memory battery, it is recommended to leave the unit plugged into the wall socket. If you are using a modem, you must have power applied to transmit or receive data.

If the NET switch in configuration options is turned on, then a sixth page will appear as shown. The options for the "log" function are described in the Network Installation/Operation Manual (P/N 881-503).

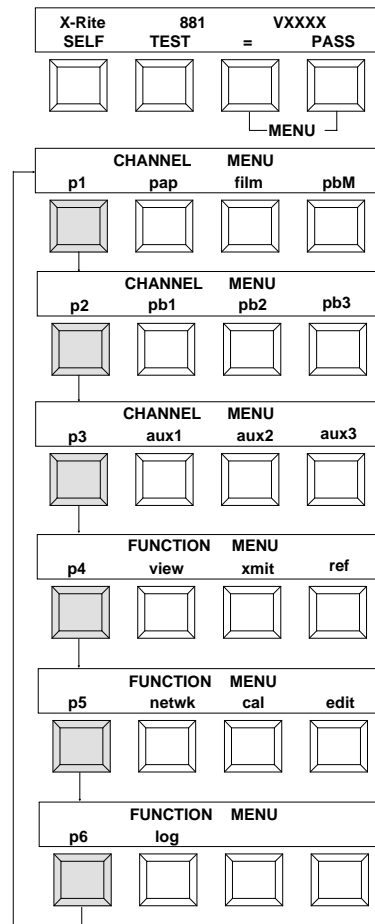

5. Keyboard Functions

The instrument has fifteen basic functions:

- **pap** (Paper) - sets the unit to the paper measuring function (ex., EP2, RA-4, CP-21, AP-92, R-3, P-3, etc.). The paper format selected will remain selected until changed.
- **film** - sets the unit to the film measuring function (ex., C-41, KBM, etc.). The film format selected will remain selected until changed.
- **pbM** - (Printer Balance Master) - sets the unit into the main printer balance measuring function (ex., Black Ringed Bull's-Eye, White Ringed Bull's-Eye, Cropped Bull's-Eye etc.). The printer balance format selected will remain selected until changed.
- **pb1- pb3** (Printer Balance 1-3) - allows for measurement tracking of three additional printer balance control strip formats. The printer balance selected will remain selected until changed.
- **aux1 - aux3** (Auxiliary 1-3) - allows for measurement tracking of three additional control strip formats (paper, film, or printer balance).
- **view** - used to view the data of the last two reference strips measured, and the last 16 control strips measured for each channel.
- **xmit** (Transmit) - used to manually transmit the data of the last two reference strips measured, and up to 16 previous control strips measured for each channel via the RS232 port.
- **ref** (Reference) - used to select a reference strip, enter the correction value (if required), and measure the respective strip. The measured reference strip with correction factors applied are then stored and used when a control strip of the same format is measured. The control strip measured under the paper, film, or printer balance function can then be compared to the "aim" values generated from the reference strip, to determine if a limit (action/control/spread) has been exceeded. Actual *deviation from aims* data can be displayed for easy plotting of process monitoring clothesline plots.
- **netwk** (Network) - provides a link between the instrument and QC computers.
- **cal** (Calibrate) - used for calibration.
- **ava** (Aim Value Adjustments) - used to adjust the aims value (if required).
- **cnfg** (Configuration) - allows presetting of certain functions.
- **del** (Delete) - allows stored references and measurements to be erased.
- **time** - allows the date and time to be preset.
- **log** - allows configuration of and data entry into the internal log buffer.

Most of the functions have a built-in "HELP" message. To activate the help message simply hold the key depressed until the message is displayed, and then release. The message can be temporarily paused by pressing the key back down while the message is scrolling.

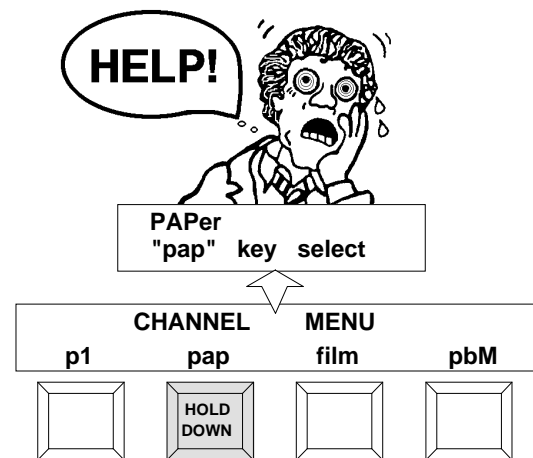

5.1 Strip Format Flow Chart

Up to nine different strip formats can be stored with measurement information at any given time (one format per channel).

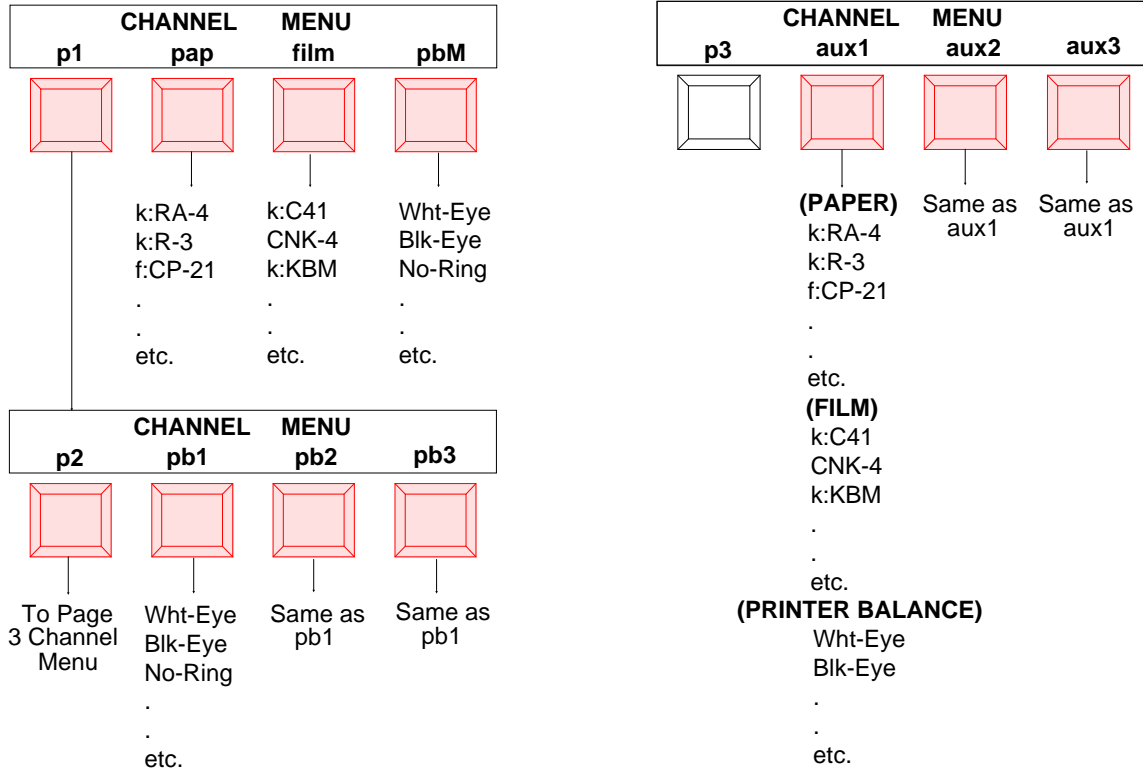

Refer to the Control Strip and Balance Print Format Guide for a complete listing of available control strips.

☞ When reading a strip into Aux 1, 2, or 3 channels, the data is not loaded into the database of the strip memory automatically. The instrument will display "LOAD INTO AUX CHANNEL? no yes", by doing so the Aux 1, 2, and 3 channels can be used as scratch pad channels to measure strips without loading into the database.

6. Configuring Your Instrument

Your instrument should initially be configured (date, time, tone, etc.) before proceeding to reference entry or control strip measurement.

The procedure below is used to set the time and date in your unit.

Time & Date

Step 1 - At Channel Menu level, repeatedly press [p#] until "p5" is displayed. Then press the [edit].

Step 2 - Press the [time] to activate the time set function.

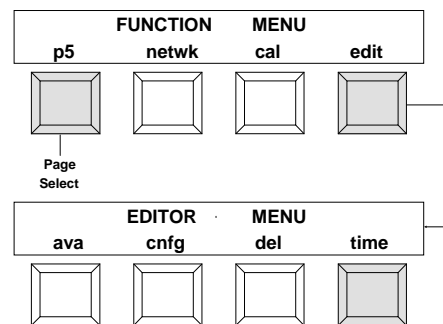

Step 3 - Set the date and time.

- [→] moves the cursor to the next digit.
- [↑] increases the value marked by cursor.
- [↓] decreases the value marked by cursor.

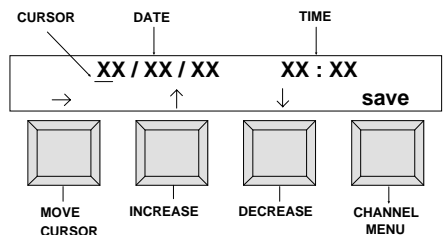

Step 4 - Press [save] to save changes and return to Editor Menu.

Configuring Your Instrument - continued

Shown below is the procedure for modifying the unit configuration parameters. Refer to Appendix A3 for a more detailed explanation of the available options.

☞ When a certain function is On or Off, the function will display in uppercase letters for On and lowercase letters for Off.

Unit Configuration

Step 1 - Refer to Appendix A3 to decide upon desired CNFG settings.

Step 2 - At Channel Menu level, continually press [p#] until "p5" is displayed. Then press [edit].

Step 3 - Press [cnfg] to activate configuration program.

Step 4 - Set lang (Language option not available at this time).

Step 5 - Set tone control. Each depression of [TONE] will page through "OFF", "SOFT", and "LOUD."

Step 6 - Set net (only set if a network modem is to be used). Each depression of [net] will page through "OFF", "OUT", "IN", and "I&O."

Step 7 - Press [P1] to advance to Page 2 configuration setup.

Step 8 - Press [IO preset] once (either center key) to initiate setup. Each depression, thereafter, of [IO preset] will page through "CUSTOM", "REPORT", "SPRD-SHT", "k:TNetA", "k:TNetXT", etc.

Step 9 - Press [load] to load in I/O preset and advance to "P2a" menu, or press [P2] to not load in preset and advance to "P2a" menu.

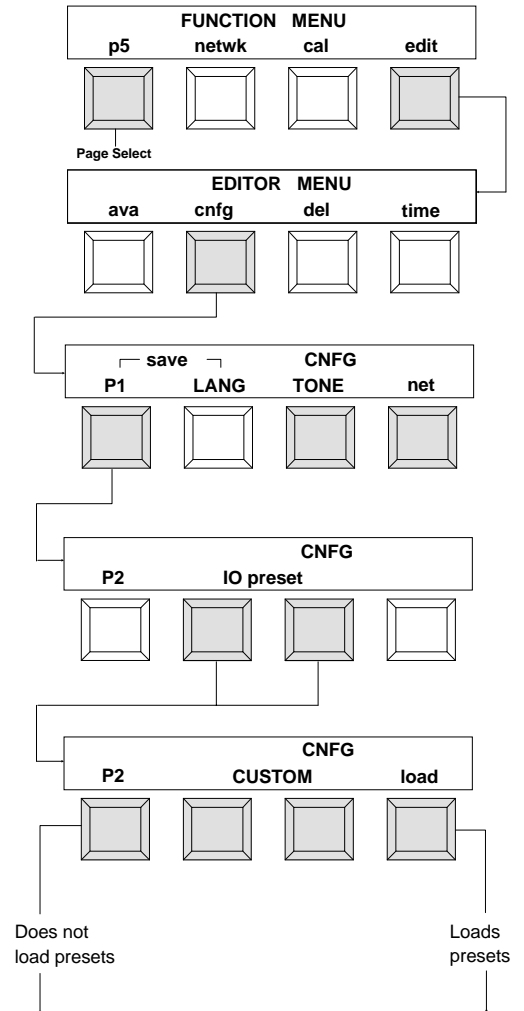

Configuring Your Instrument - continued

- Step 10 - Set rci.* Each depression of [**rci**] will page through "OFF", "ON", and "TTL."
- Step 11 - Set pin5.* Each depression of [**pin5**] will page through "OFF", "CTS", and "BUSY."
- Step 12 - Set xon.* Each depression of [**xon**] will alternate between "XON" (On) and "xon" (Off).
- Step 13 - Press [P2a]* to advance to Page 2b configuration setup.
- Step 14 - Set dpt.* Each depression of [**dpt**] will alternate between "DPT" (On) and "dpt" (Off).
- Step 15 - Set comp.* Each depression of [**comp**] will alternate between "COMP" (On) and "comp" (Off).
- Step 16 - Set alf.* Each depression of [**alf**] will alternate between "ALF" (On) and "alf" (Off).
- Step 17 - Press [P2b]* to advance to Page 2c configuration setup.
- Step 18 - Set del.* Each depression of [**del**] will alternate between "DEL" (On) and "del" (Off).
- Step 19 - Set axmt.* Each depression of [**axmt**] will alternate between "AXMT" (On) and "axmt" (Off).
- Step 20 - Set ref.* Each depression of [**ref**] will alternate between "REF" (On) and "ref" (Off).
- Step 21 - Press [P2c]* to advance to Page 2d configuration setup.
- Step 22 - Set baud.* Each depression of [**baud**] will page through "110", "300", "600", "1200", "2400", "4800", "9600."
- Step 23 - Set lock.* Insert a piece of paper into the paper slot far enough to activate the read switch (approx. 1-1/4" or more). Heavy paper or film works best. Each depression of [**lock**] will alternate between "LOCK" (options not changeable) and "lock" (options changeable). **Note:** A padlock icon will appear close if options are locked.
- Step 24 - Press [P2d] and [baud]* together to save the configuration changes.

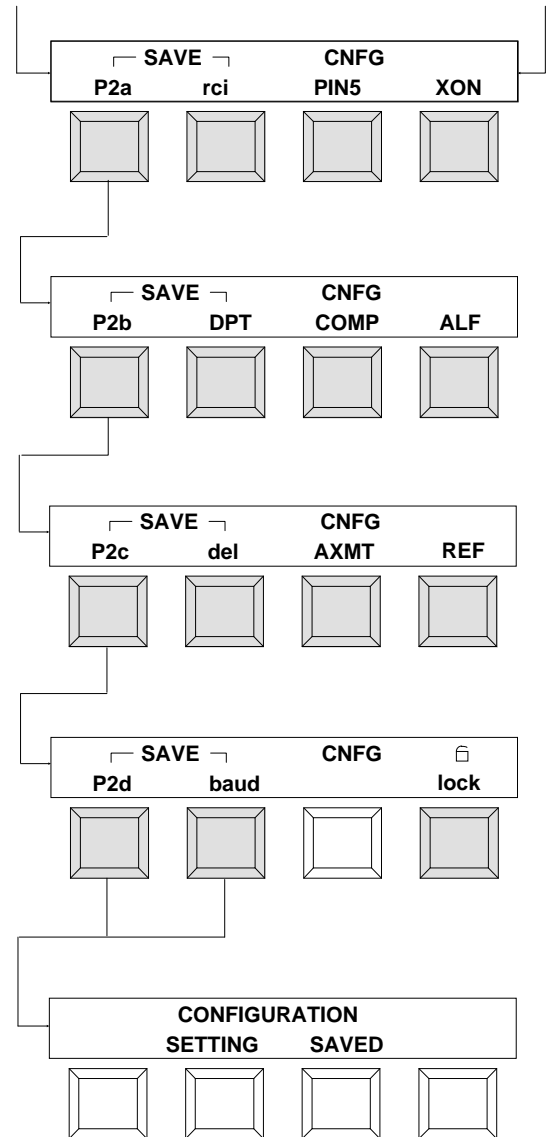

"Configuration Setting Saved" is displayed, then display returns to Channel Menu.

- ☞ When the keys labeled "MENU" are pressed together at anytime, the configuration procedure will be exited and the configuration changes made (if any) will NOT be saved.

7.

Adjusting Paper Guides

To accommodate different size strips, the instrument has an adjustable paper guide on each side of the strip entrance. Each paper guide has a pointer (triangle) that must be in line with the mark that you are going to set to.

The paper guide has settings marked 9 thru 30 to the left and right of the center diamond. Each mark is a 1/10 inch increment. 10 is equal to one inch and 20 equal to two inches.

The instrument will automatically display the left and right setting you should set the paper guides to.

EXAMPLE:

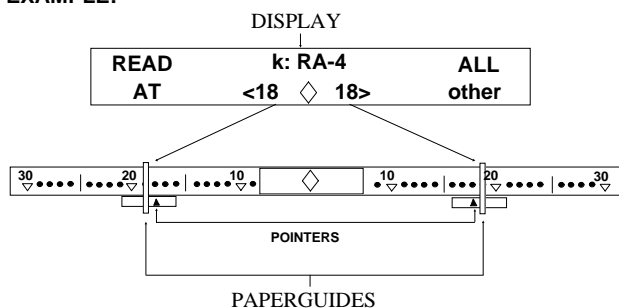

To move the paper guides to the desired location, lift-up on bottom slightly and slide left or right (see below).

INCORRECT

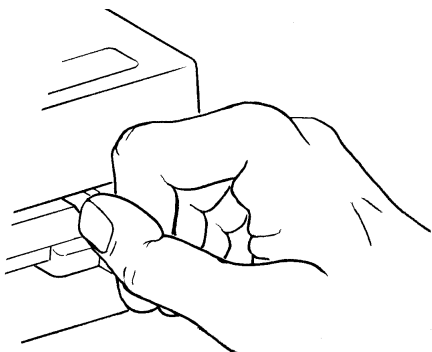

INCORRECT

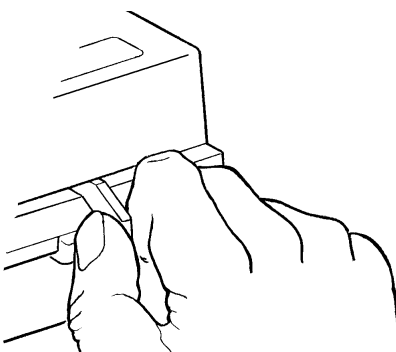

CORRECT

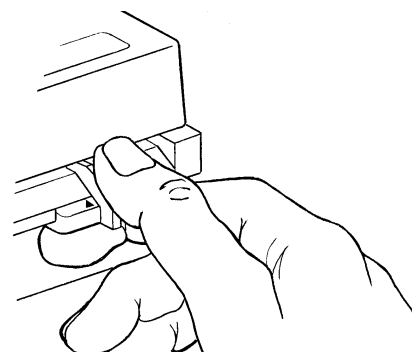

To accommodate 35mm wide strips, the instrument has a special stationary guide located above the diamond.

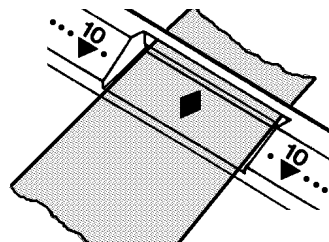
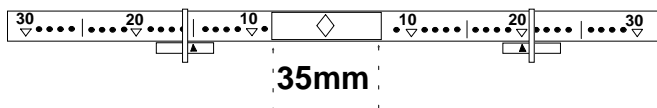

Due to the amount of variation in printer balance strips, there are no paper guide setting displayed for any printer balance format.

8.

Establishing AIM Values

Aim values are used as a reference point for a measured control strip to be compared with. If any of the predefined limits (action, control, or spread) are exceeded, the unit will automatically display the limit exceeded. Aim values are established on the instrument by:

- Measuring the preprocessed reference strip(s).
- Entering correction factors (if required) for the various fields of a strip.
- Performing a crossover procedure (if desired) to reduce the effect of changing from old reference strips to new reference strips.
- Adjusting the aim values (optional).

☛ The Correction Factor Adjustment and Crossover Procedure are not available when measuring a printer balance reference strip.

8.1. Measuring a Paper Reference Strip

The method for measuring a paper reference strip is shown below.

PAPER EXAMPLE (RA-4)

Step 1 - At Channel Menu level, continually press [p#] until "p4" is displayed, then press [ref].

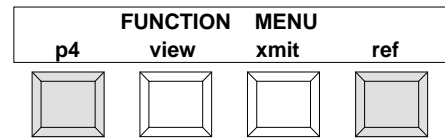

Step 2 - Select Reference channel.

- Press channel select key until "pap" is displayed.
- Press [go>].

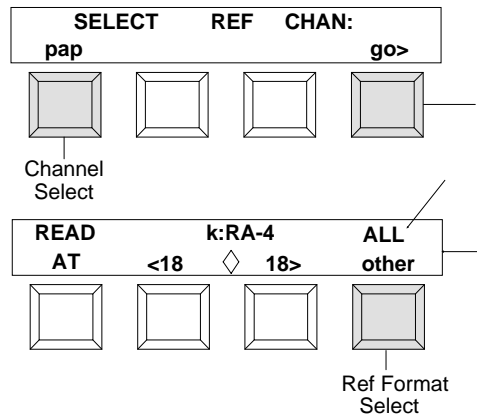

Step 3 - Select Reference format.

- Press [other] to select "k:RA-4" format.
- Adjust the paper guides according to the numbers displayed.
- Insert the strip, note which color is to be measured, as displayed by the unit.

☛ For more information on paper strips and paper strip insertion direction, refer to the Control Strip & Balance Print Format Guide, Section 1.

Step 4 - If the strip has more than one column to measure, the densitometer will indicate the number of passes required.

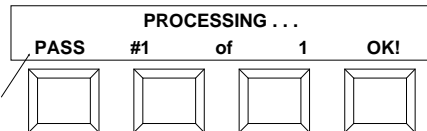

Measuring a Paper Reference Strip - continued

Step 5 - After the first paper reference strip measurement is complete, the unit will ask if you want to average in a second strip. The unit will allow up to 8 reference strips to be measured.

- Press **[no]** to proceed to next step; if **[yes]** is pressed, display will prompt you to read 2nd strip.

☛ "REF MISMATCH CONTINUE? no yes" will display after measuring a reference strip(s), if a different strip format was previously entered in that channel. Press **[yes]** to continue to next step, or press **[no]** to exit out of reference program.

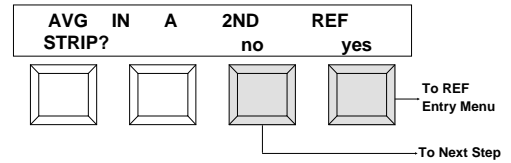

Step 6 - The display asks you to enter a batch ID number for the new reference strip that was measured. The instrument will allow six digits or characters to be used as an ID number.

- [↑] increases the digit/character marked by cursor.
- [↓] decreases the digit/character marked by cursor.
- [→] moves the cursor to the next position.

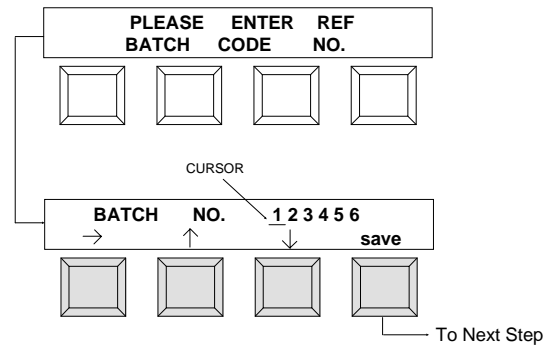

Step 7 - After the batch code entry is saved, you are asked if you want to enter correction factors.

- Press **[no]** to proceed to next step; if **[yes]** is pressed, refer to Section 8.4 (Correction Factors).

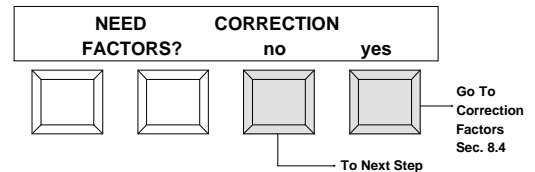

Step 8 - Next, you are asked if you want to do a reference crossover.

- Press **[no]** to proceed to next step; if **[yes]** is pressed, refer to Section 8.5 (Crossover).

☛ This step is skipped for first Ref entered for any channel because no old Reference exists.

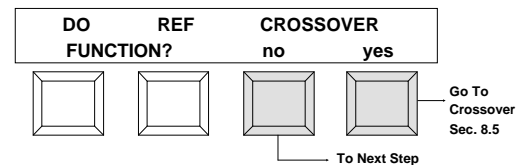

Step 9 - The display indicates that the new reference has been entered and allows you to view the data. Press **[no]** or **[yes]**.

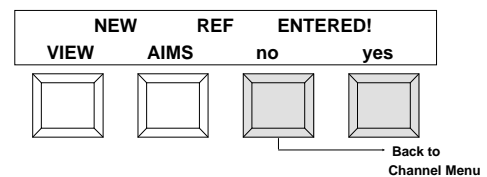

8.2. Measuring a Film Reference Strip

The method for measuring a film reference strip is shown below.

FILM EXAMPLE (C41)

Step 1 - At Channel Menu level, continually press [p#] until "p4" is displayed, then press [ref].

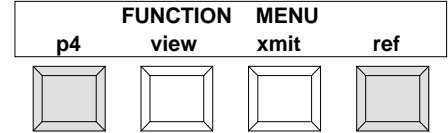

Step 2 - Select Reference channel.

- Press channel select key until "film" is displayed.
- Press [go>].

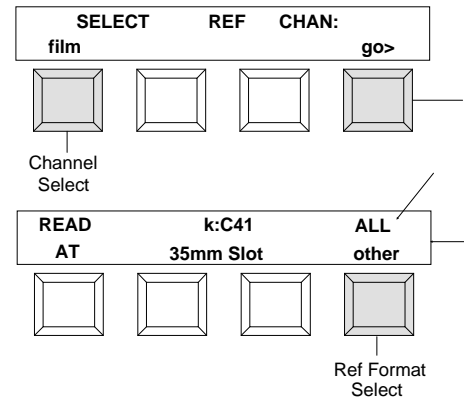

Step 3 - Select Reference format and measure strip.

- Press [other] to select "k:C41" format.
- Insert film strip into the 35mm film slot until it rest against the drive rollers.

For more information on film strips and film strip insertion direction, refer to the Control Strip & Balance Print Format Guide, Section 1.

Step 4 - The densitometer will indicate that processing is taking place, and the number of passes required.

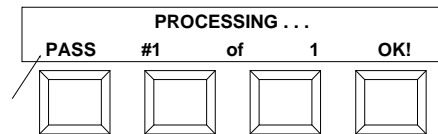

Measuring a Film Reference Strip - continued

Step 5 - After the first film reference strip measurement is complete, the unit asked if you want to average in a second strip. The unit will allow up to 8 reference strip to be measured.

- Press **[no]** to proceed to next step; if **[yes]** is pressed, display will prompt you to read 2nd strip.

☛ "REF MISMATCH CONTINUE? no yes" will display after measuring a reference strip(s), if a different strip format was previously entered in that channel. Press **[yes]** to continue to next step, or press **[no]** to exit out of reference program.

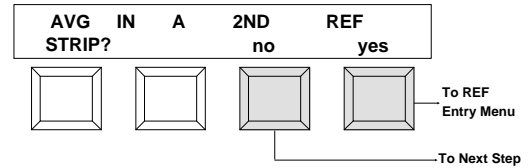

Step 6 - The display asks you to enter a batch ID number for the new reference strip that was measured. The instrument will allow six digits or characters to be used as an ID number.

- [↑] increases the digit/character marked by cursor.
- [↓] decreases the digit/character marked by cursor.
- [→] moves the cursor to the next position.

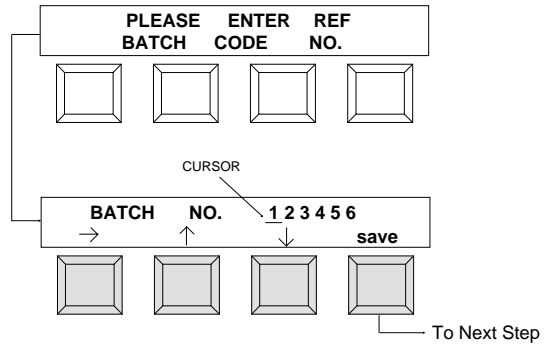

Step 7 - After the batch code entry is saved, you are asked if you want to enter correction factors.

- Press **[no]** to proceed to next step; if **[yes]** is pressed, refer to Section 8.4 (Correction Factors).

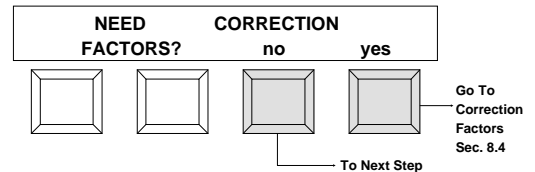

Step 8 - Next, you are asked if you want to do a reference crossover.

- Press **[no]** to proceed to next step; if **[yes]** is pressed, refer to Section 8.5 (Crossover).

☛ This step is skipped for first Ref entered for any channel because no old Reference exists.

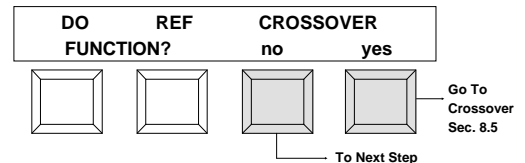

Step 9 - The display indicates that the new reference has been entered and allows you to view the data. Press **[no]** or **[yes]**.

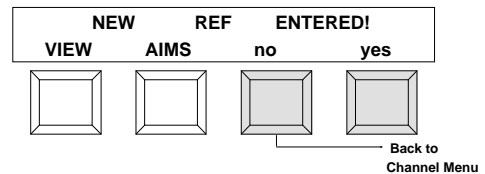

8.3. Measuring a Printer Balance Reference Strip

The method for measuring a printer balance reference strip is shown below.

PRINTER BALANCE EXAMPLE (White-Eye, UNO)

Step 1 - At Channel Menu level, continually press **[p#]** until "p4" is displayed, then press **[ref]**.

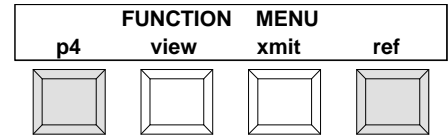

Step 2 - Select Reference channel.

- Press channel select key until "pbM" is displayed.
- Press **[go>]**.

Step 3 - Select Reference format and Print Number.

- Press **[other]** to select "Wht-Eye" format.
- Press print select key until "UNO 1-Pass" is displayed.

☞ "Multi- ##" can not be selected for any strip format when measuring printer balance reference strips.

Step 4 - Measure strip.

- With under end of strip facing unit (as indicated in display), position strip with center of bull's-eye over middle diamond. Slide paper guides next to strip.
- Insert strip until it rest against the drive rollers.

☞ For more information on printer balance strips and their requirements, refer to the Control Strip & Balance Print Format Guide, Section 2.

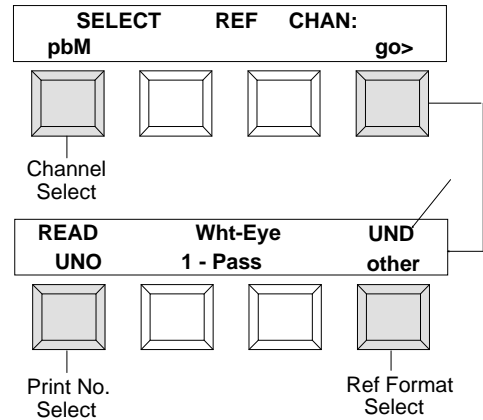

Step 5 - The densitometer will indicate that processing is taking place, and the number of passes required.

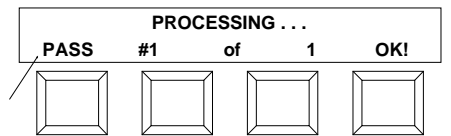

Measuring a Printer Balance Reference Strip - continued

Step 6 - After the first printer balance reference strip measurement is complete, the unit asked if you want to average in a second strip. The unit will allow up to 8 reference strips to be measured.

- Press **[no]** to proceed to next step; if **[yes]** is pressed, display will prompt you to read 2nd strip.

☛ **"REF MISMATCH CONTINUE? no yes"** will display after measuring a reference strip(s), if a different strip format was previously entered in that channel. Press **[yes]** to continue to next step, or press **[no]** to exit out of reference program.

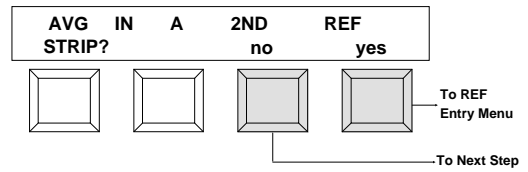

Step 7 - The display asks you to enter a batch ID number for the new reference strip that was measured. The instrument will allow six digits or characters to be used as an ID number.

- [↑] increases the digit/character marked by cursor.
- [↓] decreases the digit/character marked by cursor.
- [→] moves the cursor to the next position.

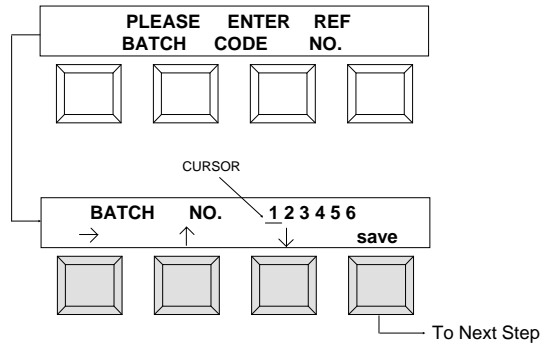

Step 8 - The display indicates that the new reference has been entered and allows you to view the data. Press **[no]** or **[yes]**.

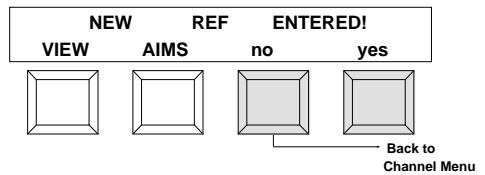

8.4. Correction Factor (CF) Entry

(Continued from Step 7 of Section 8.1 or Section 8.2)

Step 7a - Enter the value for each field measured.

- [↑] increases the value marked by cursor.
- [↓] decreases the value marked by cursor.
- [→] moves the cursor to the next color.
- [D-min] the field select key cycles through the field names.
- Note, after the value for the last field has been entered press the field select key once to advance to the next display.

Step 7b - The display indicates that the correction factors are ready to be loaded.

- Press [review] to review (or edit) the correction factors you've just entered.
- Press [continue] to load the correction factors and continue with Reference entry (at Step 8, Section 8.1 or Section 8.2).

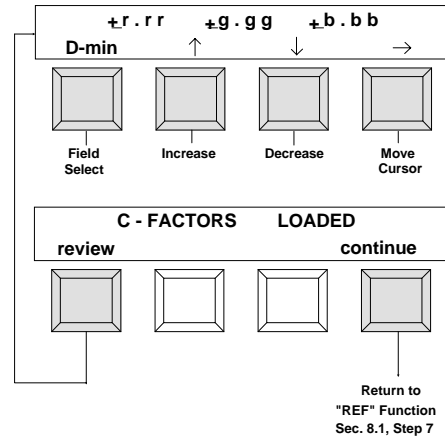

8.5. Crossover Procedure

(Continued from Step 8 Section 8.1 or Section 8.2)

Step 8a - "PLEASE READ OLD QC STRIPS (3)" is momentarily displayed.

- Read 1st old strip.
- Read 2nd old strip.
- Read 3rd old strip.
- [abort] will allow you to exit out of the crossover function.

Step 8b - "PLEASE READ NEW QC STRIPS (3)" is momentarily displayed.

- Read 1st new strip.
- Read 2nd new strip.
- Read 3rd new strip.
- The display indicates that Crossover is complete and then asks if you want to view Aims.
- Press [yes] to view Aims. Press [no], and return to Step 9 of Sec. 8.1 or Sec. 8.2.

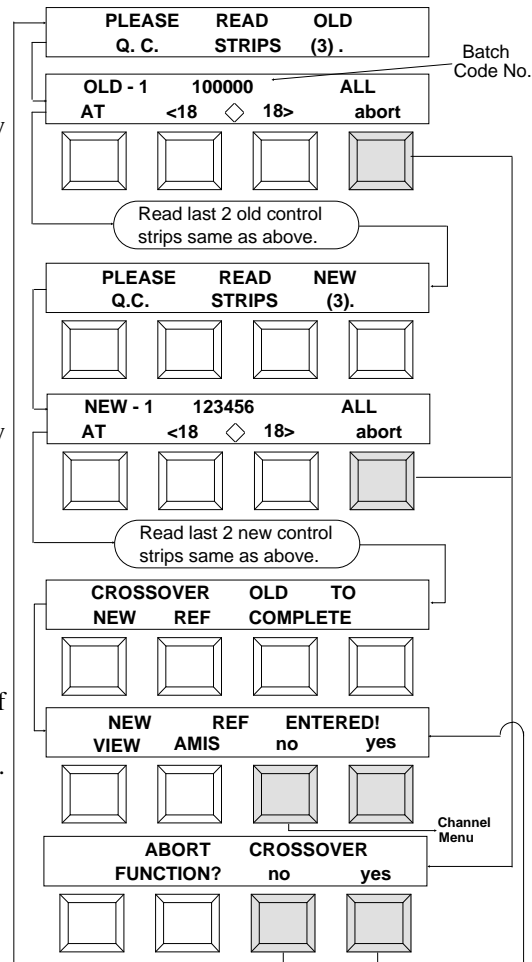

8.6. Aim Value Adjustments (AVA)

Step 1 - At Channel Menu level, continually press [p#] until "p5" is displayed. Then press the [edit].

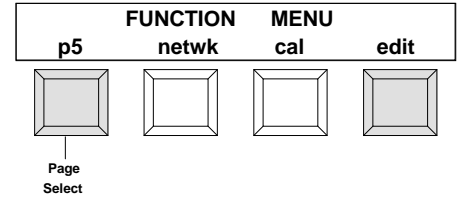

Step 2 - Press [ava].

Step 3 - Repeatedly press the channel select key, to select proper channel. Press [go>].

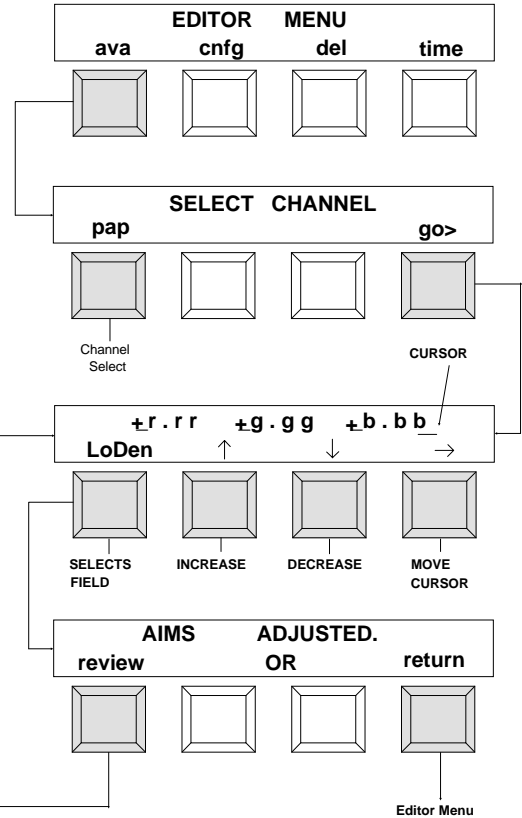

Step 4 - If desired, adjust the AVA for each field displayed.

- [↑] increases the value marked by cursor.
- [↓] decreases the value marked by cursor.
- [→] moves the cursor to the next color.
- Note, after the value for the last field has been entered, press the field select key once to advance to next display.

Step 5 - The display indicates the aim value adjustments are ready to be saved.

- Press [review] to review (or re-edit) the aim value adjustments.
- Press [return] to save aim value adjustments and return to "EDITOR MENU."

The aim value adjustments (AVA) are range limited and will not exceed the aim value adjustment tolerances (AVAT's) set in the unit. You can abort all changes made by pressing the two keys labeled "Menu" prior to saving via the [return] key, and thereby abort all AVA adjustments made since entering the function. AVA's will be left just as they were upon entering the AVA function.

9. Taking Measurements

The following examples show you how to measure strips. The first example is a general procedure showing the basic steps for measuring any type of strip. The remaining examples show how to measure specific strips: Example 2 (3 pass paper - CP21); Example 3 (film - C41); and Example 4 (printer balance - U.N.O. 1-pass, black ring bull's-eye).

IMPORTANT! When inserting strips (Paper, Film, or Printer Balance) into unit, there should be at least a 1-1/8 inch (28mm) leader before the outside edge of the first target. If not, the first target may not be detected. For leaderless strip measurements (less than 28mm), see Control Strip & Balance Print Format Guide, Sec. 4.

EXAMPLE 1:

Step 1 - Select strip channel. Select desired channel from page 1, 2, or 3.

For proper insertion direction of your particular strip, see Control Strip & Balance Print Format Guide, Sec. 1.

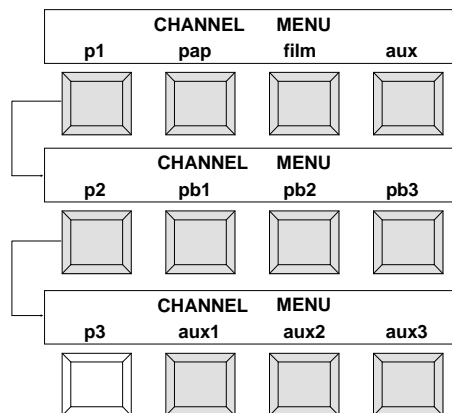

Step 2 - If the strip **format** is not correct, press **[other]** until the desired **format** is displayed.

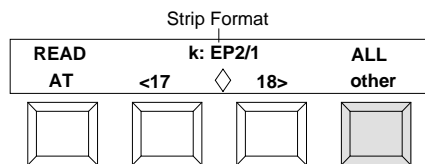

Step 3 - Adjust the paper guides according to the numbers displayed.

There are no paper guide settings displayed for the printer balance strips.

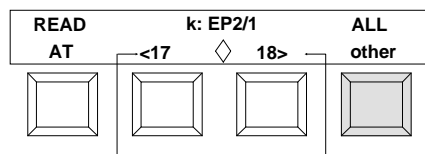

Step 4 - Insert the strip until it rests against the drive rollers. If measuring a multi-pass strip, note which color is to be measured (as displayed in upper right corner) and which paper guide to align strip with for each pass. (For any pass the flashing guide no. indicates which guide(s) to use.)

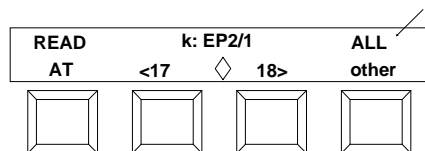

Step 5 - After the strip is measured "**PASS #1 OF 1 OK!**" will be displayed if the strip measured correctly.

- If the strip has more than one column to measure, the instrument will indicate the number of passes required.

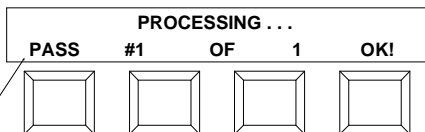

SECTION 9



Taking Measurements - continued

What happens next is dependent on the Ref and Auto Transmit settings in Configuration Setup. If REF is enabled (On) in configuration and reference data exists for the strip measurement, go to Step 6a. If ref is disabled (Off) or reference data does not exist, go to Step 6b. In either case, if auto transmit is enabled in configuration, "TRANSMITTING DATA" is momentarily displayed after the measurement is taken.

Step 6a - View Data (For paper, film, or printer balance channels)

- The time and date (Time Tag) is momentarily displayed.
- The control limit pass or violation message is displayed along with "VIEW DATA no yes."
- Press **[no]** if you do not want to view data. The display will return to the channel menu.
- Press **[yes]** if you want to view the data. Refer to Section 10 Viewing Data, for a complete explanation on all data that can be viewed.

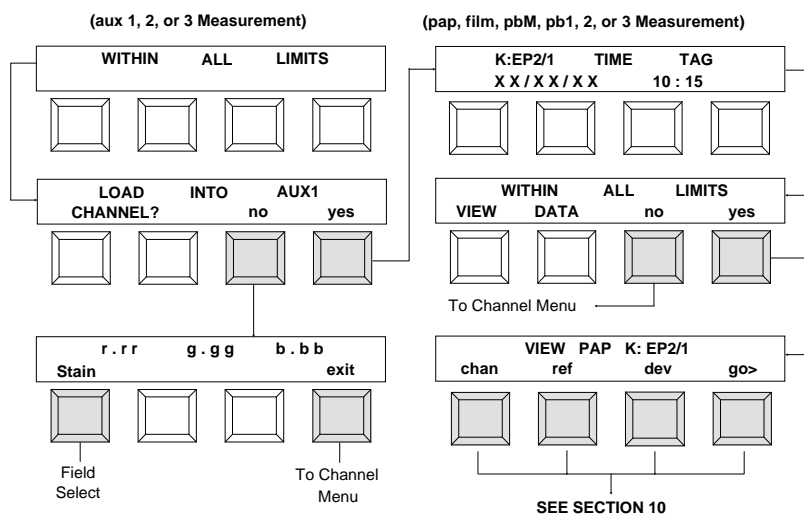

Step 6a - View Data (For auxiliary channels)

- The control limit pass or violation message is momentarily displayed.
- The display asks if you want to load data measured into the auxiliary channel. This allows the auxiliary channels to be used as "scratch pads" without saving measurements to memory.
- Press **[no]** and the measured fields can be viewed, but not loaded into memory.
- Press **[yes]** the measurement is loaded into memory, display will indicate the time tag and allow data to be viewed. Refer to Section 10 for information on viewing data.

Step 6b - The measured data is displayed.

- Press **[stain]** the field select key, to page through fields.

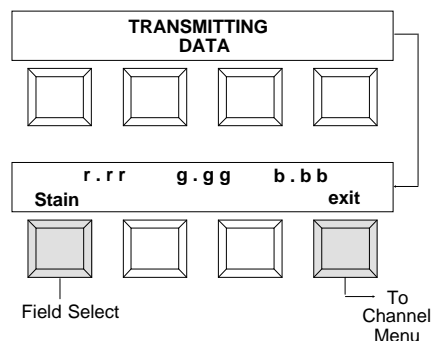

☛ If "INVALID READING", "UNRECOGNIZABLE STRIP", or "BUFFER OVERFLOW" is displayed after strip is measured, try re-reading strip. If the same error message occurs after re-reading strip, refer to the Appendix, Sec. A1.

If the strip gets jammed in the unit, press the two keys labeled "MENU." If this does not feed strip out, pull strip out slowly from the front of unit.

The instrument will not measure creased strips.

9.1. Measuring a Color Paper Strip

EXAMPLE 2 (CP21 Strip)

Step 1 - Press **[pap]**.

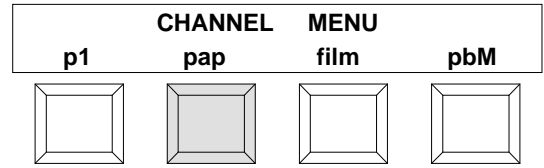

Step 2 - If "f:CP21" is not displayed, press **[other]** until it is.

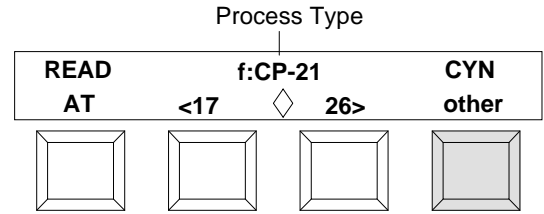

Step 3 - Set the paper guides as displayed. Left to 17 and right to 26.

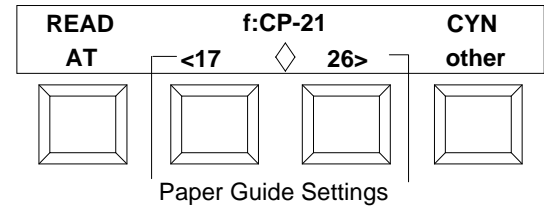

Step 4 - Align the strip with right guide (indicated by flashing right guide no.) so you can measure the Cyan and Stain fields.
Insert strip until it rests against the drive rollers.

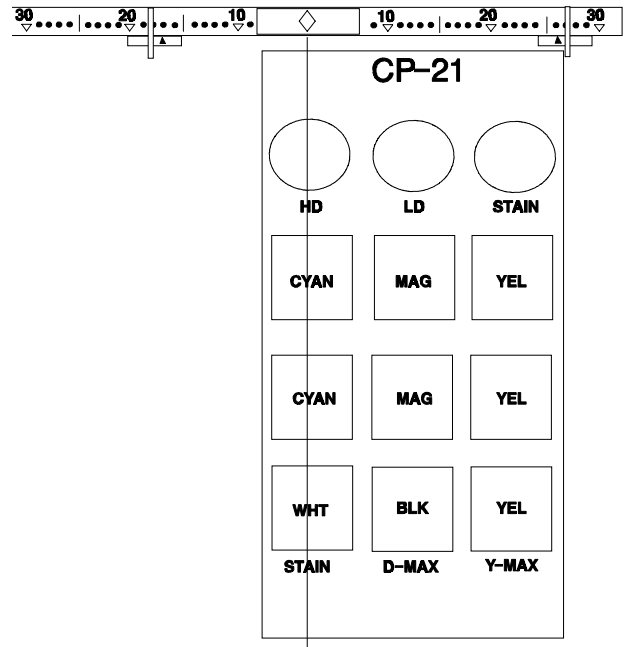

Measuring a Color Paper Strip - continued



Step 5 - When prompted by display, align the strip with left guide (indicated by flashing left guide no.) so you can measure the Magenta and Black fields.

Insert strip until it rests against the drive rollers.

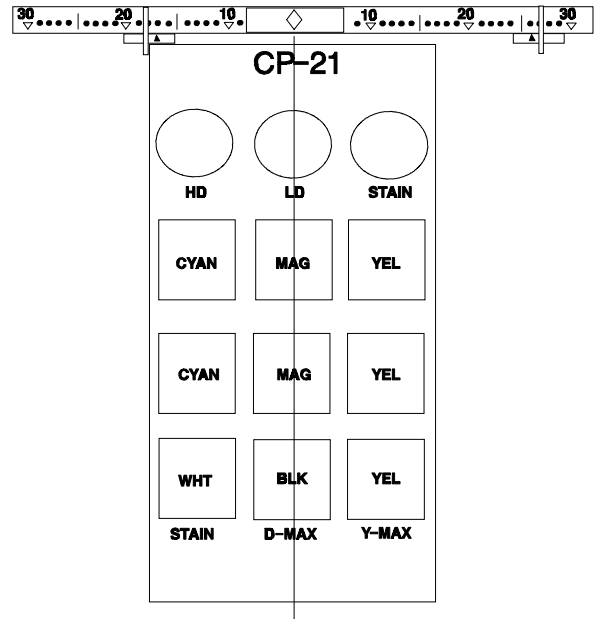

Step 6 - After 2nd pass complete, rotate strip and align it with the right guide so you can measure the Yellow field.

Insert strip until it rest against the drive rollers.

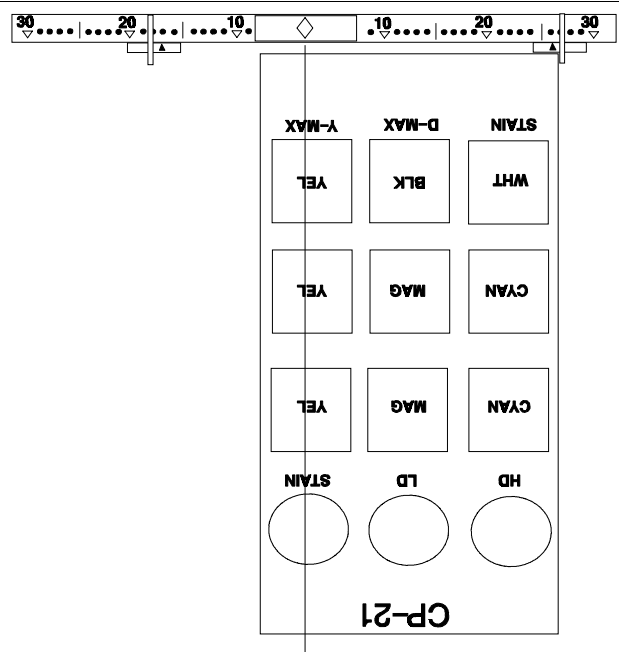

Step 7 - The display will indicate if a control limit was exceeded or show that the reading is complete. What is displayed depends if a reference was previously entered. Refer to Section 9, Steps 6a & 6b.

☞ If **"INVALID READING"**, **"UNRECOGNIZABLE STRIP"**, or **"BUFFER OVERFLOW"** is displayed after strip is measured, try re-reading strip. If the same error message occurs after re-reading strip, refer to the Appendix, Sec. A1.

9.2. Measuring a Film Strip

EXAMPLE 3 (C41 Strip)

Step 1 - Press **[film]**.

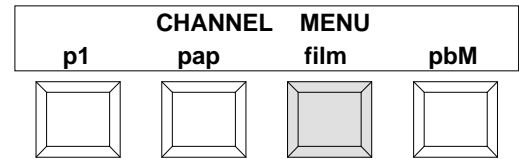

Step 2 - If "**k:C41**" is not displayed, press **[other]** until it is.

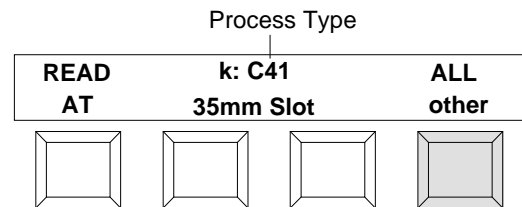

Step 3 - Insert the C41 strip into the 35mm slot until it rests against the drive rollers.

A 16mm wide C41 control strip can not be measured, due to drive mechanism.

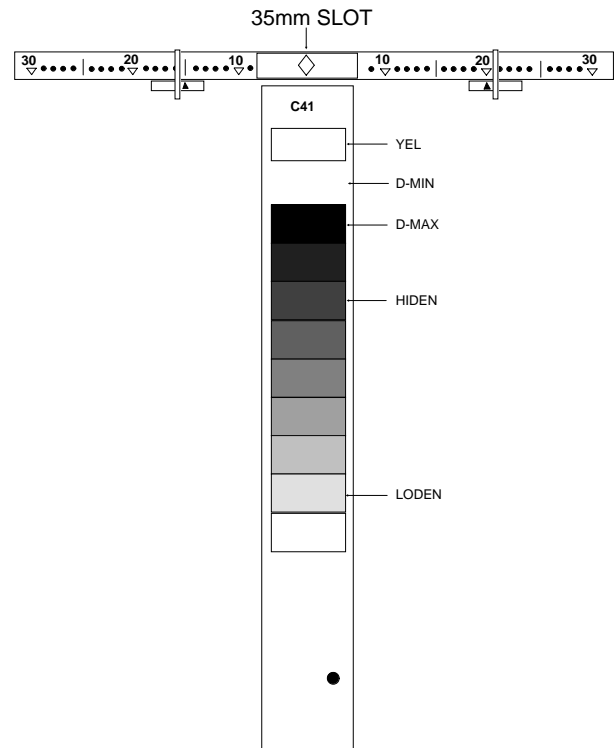

Step 4 - The display will indicate if a control limit was exceeded or show that the reading is complete. What is displayed depends if a reference was previously entered. Refer to Section 9, Steps 6a & 6b.

If "**INVALID READING**", "**UNRECOGNIZABLE STRIP**", or "**BUFFER OVERFLOW**" is displayed after strip is measured, try re-reading strip. If the same error message occurs after re-reading strip, refer to the Appendix, Sec. A1.

9.3. Measuring a Printer Balance Strip

EXAMPLE 4 (Black Ringed Bull's-Eye)

For additional details on Printer Balance see Control Strip & Balance Print Format Guide, Sec. 2.

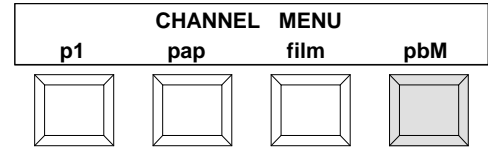

Step 1 - Press [pbM].

Step 2 - If "Blk-Eye" (Black-Ringed Bull's-eye) is not displayed, press [other] until it is.

Step 3 - Select print number. Each depression of the [Print No.] key will page through "Single", "UNO 3-Pass*", "UNO 1-Pass", "NUO 1-Pass", "5-Print", and "Multi- ↑ ## ↓."** Select "UNO 1-Pass."

☛ Bull's-eyes must be complete circles (not overlapped) to be measured properly.

* Will display N.U.O. (Normal-Under-Over) if configured for Copal® printers.

** When "Multi- ↑ ## ↓" is selected, a print measurement quantity of "0" to "35" can be entered by pressing the [↑] to increase or the [↓] key to decrease print number.

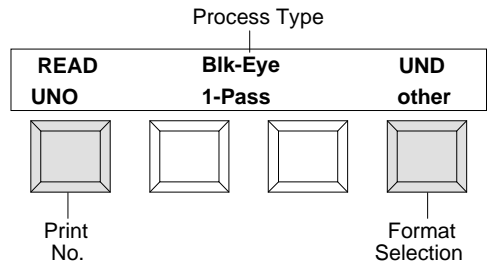

Step 4 - With "Under" end of strip facing unit, position strip with center of bull's-eye over middle diamond. Slide paper guides next to strip. Insert strip until it rests against the drive rollers.

☛ Under end of strip must be inserted first to receive values in U.N.O. sequence.

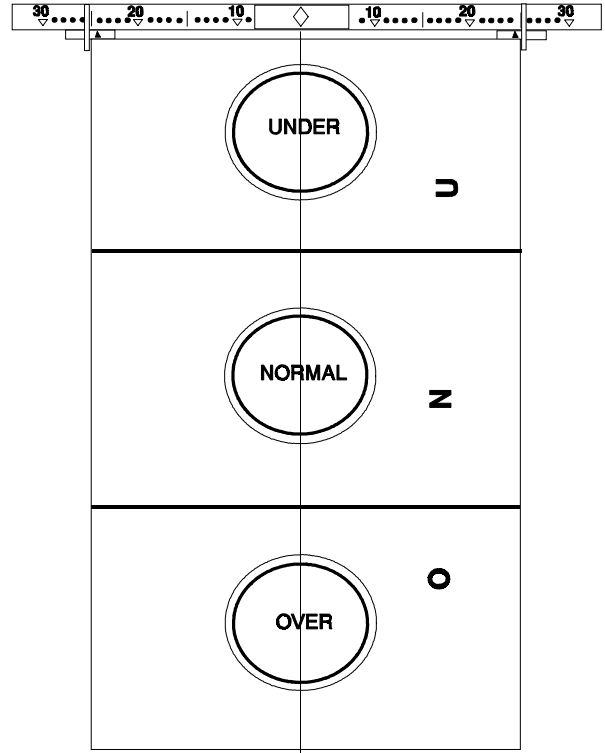

Step 5 - The display will indicate if a control limit was exceeded or show that the reading is complete. What is displayed depends if a reference was previously entered. Refer to Section 9, Steps 6a & 6b.

☛ If "INVALID READING", "UNRECOGNIZABLE STRIP", or "BUFFER OVERFLOW" is displayed after strip is measured, try re-reading strip. If the same error message occurs after re-reading strip, refer to Appendix Sec. A1.

10.

Viewing Data

There are four types of data that can be viewed: measured, reference, aims, and deviations.

- Measured values are the actual data that is read on the QC strip from a selected channel.
- Reference values are the data measured on a reference strip (average if more than one ref strip was read) for a particular channel with correction factors (if any) added in.
- Aim values are the above mentioned reference values with the transformation rules applied. Additionally any AVAs (that resulted from a crossover procedure or operator entry use EDIT MENU) will also have been added in.
- Deviations are QC strip measurements with transformation rules applied minus the above established Aim values.

* "CHANNEL IS EMPTY" or "NO REF INSTALLED" will display if no information is available in a certain channel. Measured and Deviation values can store the last 16 measurements to view per channel.

Step 1 - At Channel Menu level, repeatedly press [p#] until "p4" is displayed. Then press [view].

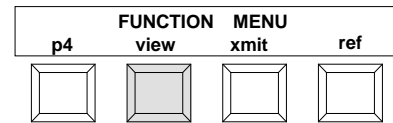

- "VIEW last (strip type)" will display first if the last strip measured was a different format than the reference previously entered in for that channel. This allows you to measure different strip formats and view data without effecting that channels memory of the last 16 strips measured.

- Press [go>] to view strip data.
- Press [chan] to go to next view menu.

* This data will not be stored in Channel Memory.

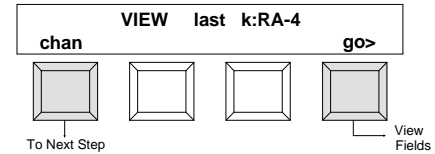

Step 2 - Select the channel to be viewed by momentarily pressing [chan].

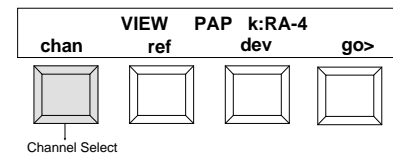

Measured QC Strip

Step 3 - Press [go>], data is displayed.

- Each field of **Measured Q.C. Strip** data can be viewed by pressing [D-min], the field select key. Note, one more depression of the field key after the last field is displayed, will allow you the choice of exiting back to main view menu or not.
- Previous strip measurements (up to 15) can also be viewed by momentarily pressing either [<] to go backward or [>] to go forward in time.
- Press [exit] to return to View Menu. Press the two keys labeled "MENU" to exit out of view and return to "CHANNEL MENU."

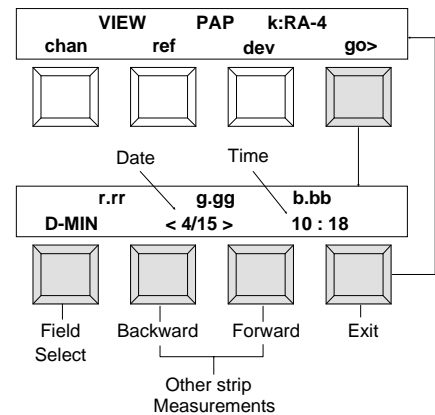

Viewing Data - continued

REF (Measured Reference)

Step 3 - Press [ref].

Step 4 - Press [go>]. The batch code no. is momentarily displayed.

- Each field of **Measured Reference** data can be viewed by pressing [**D-min**], the field select key. Note, one more depression of the field key after the last field is displayed, will allow you the choice of exiting back to main view menu or not.
- Previous reference measurement can also be viewed by momentarily pressing either [**<**] to go backward or [**>**] to go forward in time. The batch code no. assigned to the reference will momentarily display each time [**<**] or [**>**] is pressed.
- Press [**exit**] to return to View Menu.
- Press the two keys labeled "**MENU**" to exit out of view and return to "**CHANNEL MENU.**"

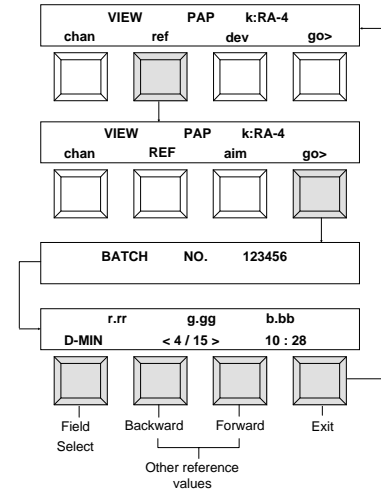

AIM (Refence Aim Values)

Step 3 - Press [ref].

Step 4 - Press [aim].

Step 5 - Press [go>].

- Each field of **Reference Aim** data can be viewed by pressing [**D-min**], the field select key. Note, one more depression of the field key after the last field is displayed, will allow you the choice of exiting back to main view menu or not.
- Previous aim values can also be viewed by momentarily pressing either [**<**] to go backward or [**>**] to go forward in time.
- Press [**exit**] to return to View Menu.
- Press the two keys labeled "**MENU**" to exit out of view and return to "**CHANNEL MENU.**"

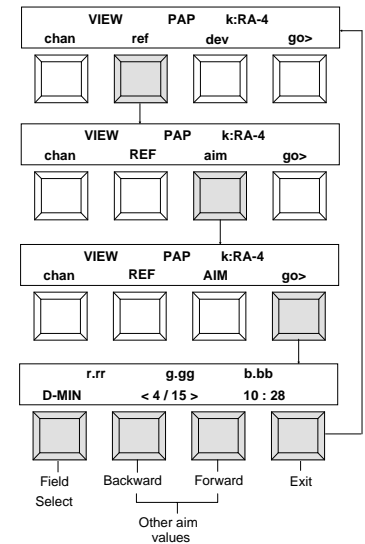

DEV (Q.C. Strip deviation from AIMS)

Step 3 - Press [dev].

Step 4 - Press [go>].

- Each field of **Deviation** data can be viewed by pressing [**D-min**], the field select key. Note, one more depression of the field key after the last field is displayed, will allow you the choice of exiting back to main view menu or not.
- Deviation Data for previous measurements (up to 15) can also be viewed by momentarily pressing either [**<**] to go backward or [**>**] to go forward in time.
- Press [**exit**] to return to View Menu.
- Press the two keys labeled "**MENU**" to exit out of view and return to "**CHANNEL MENU.**"

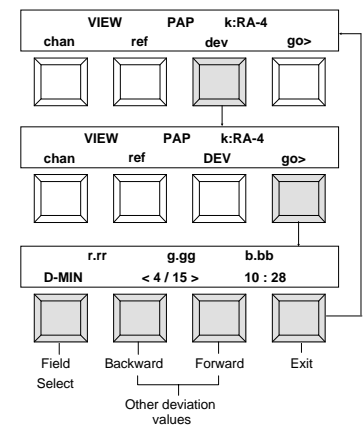

11.

Transmitting Data

There are four types of data that can be transmitted: measured, reference, aims, and deviations.

- Measured values are the actual data that is read on the QC strip from a selected channel.
- Reference values are the data measured on a reference strip (average if more than one ref strip was read) for a particular channel with correction factors (if any).
- Aim values are the reference measurements with the transformation rules applied.
- Deviations are the difference between Q.C. strip measurements (with transformation rules applied) and the established AIMS.

* **"CHANNEL IS EMPTY"** or **"NO REF INSTALLED"** will display if no information is available in a certain channel. Measured and Deviation values can store and transmit the last 16 measurements per channel.

Step 1 - At Channel Menu level, repeatedly press [p#] until "p4" is displayed. Then press [xmit].

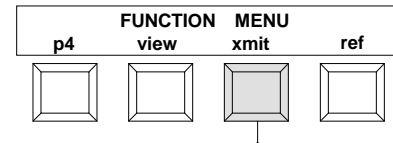

- **"XMIT last (strip type)"** will display if last strip measured was a different format than the reference previously entered in for that channel, and auto transmit is turned off in configuration. This allows you to measure different strip formats and transmit data without effecting that channels memory of the last 16 strips measured.

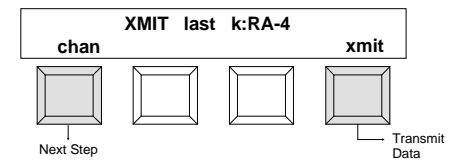

- Press [xmit] to transmit strip data and advance to the next step.
- Press [chan] to go to next step without transmitting data.

Step 2 - Select the channel to be transmitted by momentarily pressing [chan].

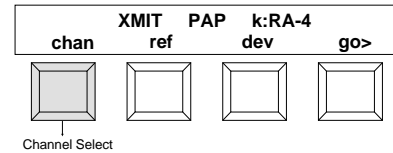

Measured

Step 3 - Press [go>].

- Select measurement to transmit by momentarily pressing either [**<**] to go backward or [**>**] to go forward in time, then press [xmit].
- If [**>**] is momentarily pressed past the last measurement, **"ALL DATA"** will display. This will allow you to transmit all the strip data of that format stored in memory (up to 16 strips), by pressing [xmit].
- Press [exit] to return to Xmit Menu.

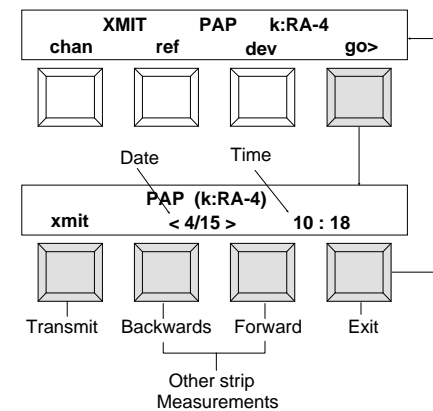

- Press the two keys labeled **"MENU"** to exit out of xmit and return to **"CHANNEL MENU."**

Transmitting Data - continued

REF (Reference)

Step 3 - Press [ref].

Step 4 - Press [go>].

- Select which set of **reference measurements** to transmit (present or last) by momentarily pressing either [**<**] to go backward or [**>**] to go forward in time.
- Press [**xmit**] to transmit reference data.
- Press [**exit**] to return to Xmit Menu.
- Press the two keys labeled **"MENU"** to exit out of xmit and return to **"CHANNEL MENU."**

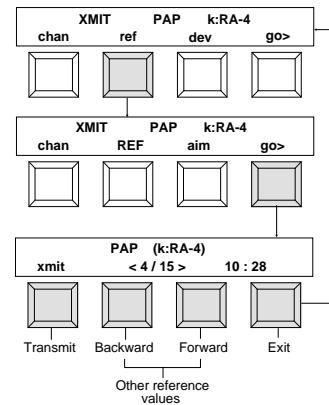

AIM

Step 3 - Press [ref].

Step 4 - Press [aim].

Step 5 - Press [go>].

- Select which set of **aim values** to transmit (present or last) by momentarily pressing either [**<**] to go backward or [**>**] to go forward in time.
- Press [**xmit**] to transmit aim data.
- Press [**exit**] key to return to Xmit Menu.
- Press the two keys labeled **"MENU"** to exit out of xmit and return to **"CHANNEL MENU."**

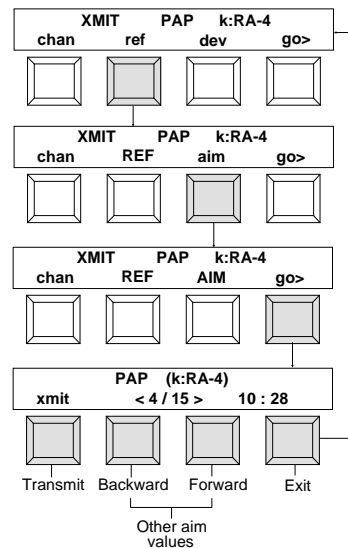

DEV (Deviations)

Step 3 - Press [dev].

Step 4 - Press [go>].

- Select deviation measurement to transmit by momentarily pressing either [**<**] to go backward or [**>**] to go forward in time.
- Press the [**xmit**] key to transmit data.
- If [**>**] is momentarily pressed past the last measurement, **"ALL DATA"** will display. This will allow you to transmit all deviation measurements (up to 16) of that channel.
- Press [**exit**] to return to Xmit Menu.
- Press the two keys labeled **"MENU"** to exit out of Xmit and return to **"CHANNEL MENU."**

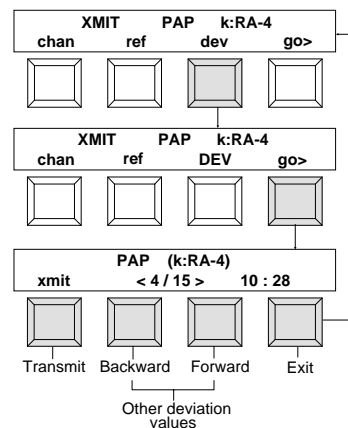

12.

Calibration

The instrument has a unique feature called *Auto-Cal*, which has a patent pending by X-Rite. When the instrument automatically calibrates, the density values are set precisely to that of the paper measured for reflection, and to no film (air) for transmission. Using a sophisticated algorithm, the slope of the instrument is calculated so that the numbers are exactly equal to the logarithmic value of the light attenuated. This allows the instrument to automatically adjust its own slope.

The instrument has many self checking algorithms built in to verify the accuracy of calibration. If you wish to maintain accuracy verification, we suggest that you obtain a C41 reference strip and a paper reference strip. Measure each strip and record the density values. Place the strips in an envelope and store them in a dry, cool environment. Periodically, measure them to verify accuracy. Note, the reference strips tend to drift in density with time, consult the manufacturer's specifications for expected density changes.

☞ The Auto-Cal strip can be cleaned with a mild soap detergent. **DO NOT** clean below the bottom triangle. The attached label is not coated and will smear when moisture is applied. **DO NOT** get fingerprints on any portion of the strip, handle by the edge.

X-Rite Auto-Cal Strip

If your Auto-Cal strip gets ruined or worn, you can order a replacement from X-Rite or your local dealer. Order Part Number 880-100.

☞ There are two types of calibration procedures, auto and manual. **AUTO is the standard method of calibration.** If you want your instrument to measure the same as another densitometer that has the same response, you can use the manual procedure (See Section 12.2).

The active calibration procedure is determined by uppercase letters. **AUTO/manual** = AUTO is active, **auto/MANUAL** = MANUAL is active.

Auto and manual will toggle between upper and lower-case letters by pressing the key below the respective function.

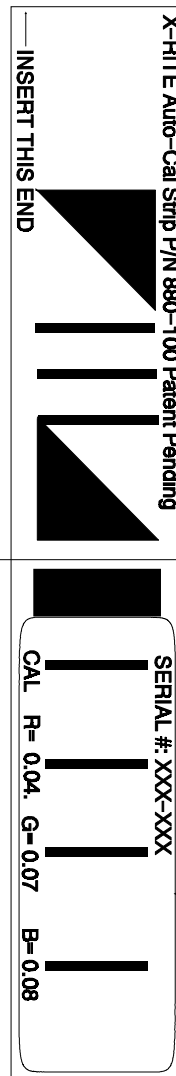
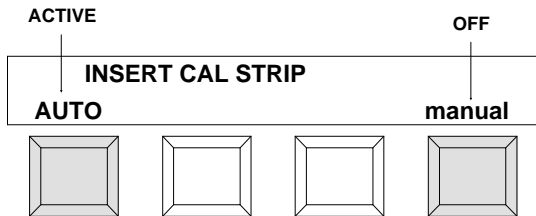

DO NOT CLEAN BELOW THIS LINE!

SECTION 12

12.1. Auto Calibration Procedure

Step 1 - At Channel Menu level, repeatedly press the [p#] until "p5" is displayed. Press [cal] to activate calibration.

"CALIBRATING TRANSMISSION" is displayed as the unit automatically calibrates transmission (reads air).

"INSERT CAL STRIP" is displayed.

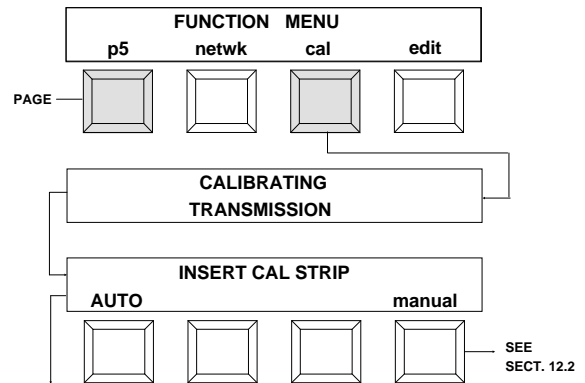

Step 2 - Insert the Auto-Cal strip into the 35mm slot until it rests against the drive rollers. The strip indicates which end to insert.

👉 If "UNRECOGNIZABLE STRIP" is displayed after strip is outputted, smudgemarks may be causing error message. Try cleaning strip (see sec. 12). If cleaning will not resolve problem, enter calibration manually then measure strip (see sec. 12.2).

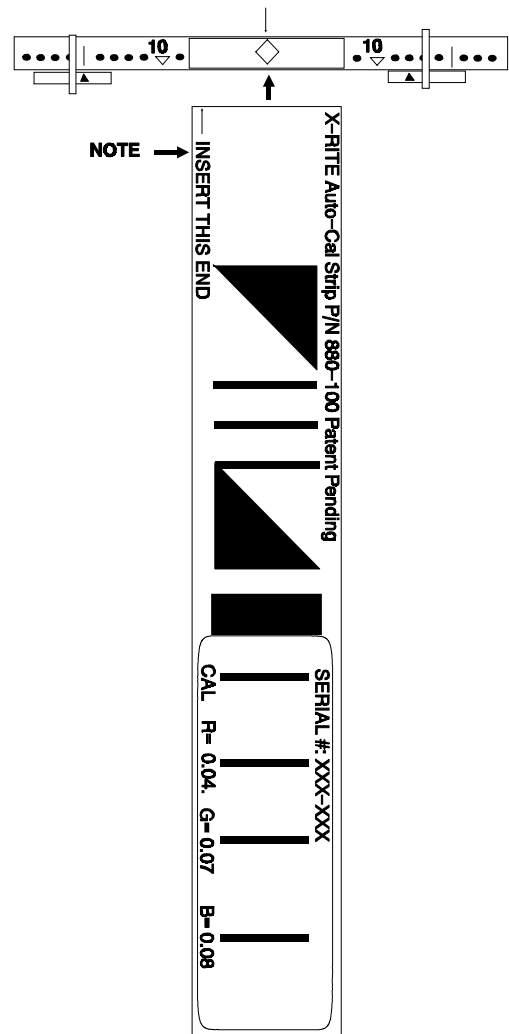

Auto Calibration procedure - cont.

Step 3 - "**READING**" is momentarily displayed. Calibration is finished and the calibration density values are displayed momentarily.

☞ The instrument will automatically return to the Channel Menu.

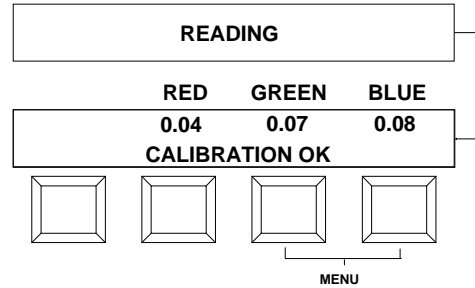

12.2. Manual Calibration or Correlating to Another Reflection Densitometer

The manual calibration procedure can be used to correlate the low densities of the instrument to another densitometer. Doing this will allow the instrument to measure approximately the same as another densitometer that has the Status A reflection response, and has been calibrated to ANSI Standards.

Step 1 - Calibrate the densitometer that you want the instrument to correlate to, using the instrument's own reference.

Step 2 - Using the same densitometer, measure the white area below the first black bar on the X-Rite Auto-Cal strip and record the Red, Green, and Blue values.

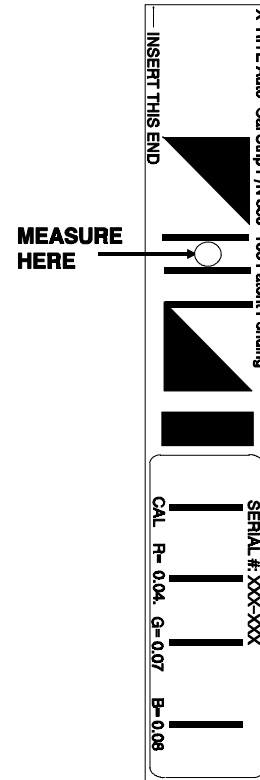

Step 3 - At Channel Menu level, repeatedly press [p#] until "p5" is displayed. Press [cal] to activate calibration.

"**CALIBRATING TRANSMISSION**" is displayed as the unit automatically calibrates transmission (reads air).

"**INSERT CAL STRIP**" is displayed. **DO NOT INSERT AUTO CAL STRIP!**

Step 4 - Press [manual].

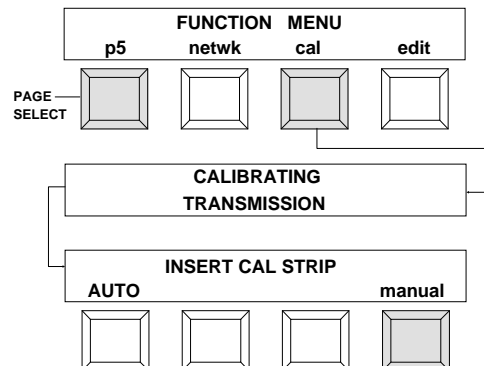

Manual Calibration - continued

The current settings are displayed.

Step 5 - Enter the Red, Green, and Blue values you recorded (In Step 2) into the instrument.

- Press [→] to advance the cursor to the next color.
- Press [↑] to increase the value.
- Press [↓] to decrease the value.
- After all values have been entered press [→] one more time to advance to next step.

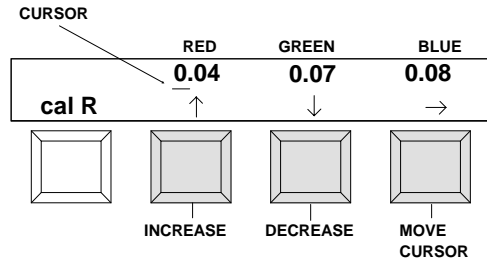

"INSERT CAL STRIP" is displayed.

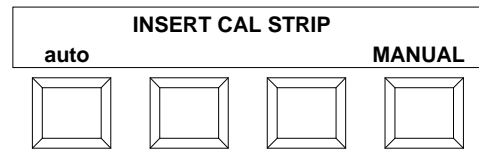

Step 6 - Insert the Auto-Cal strip into the 35mm slot until it rests against the drive rollers. The strip indicates which end to insert.

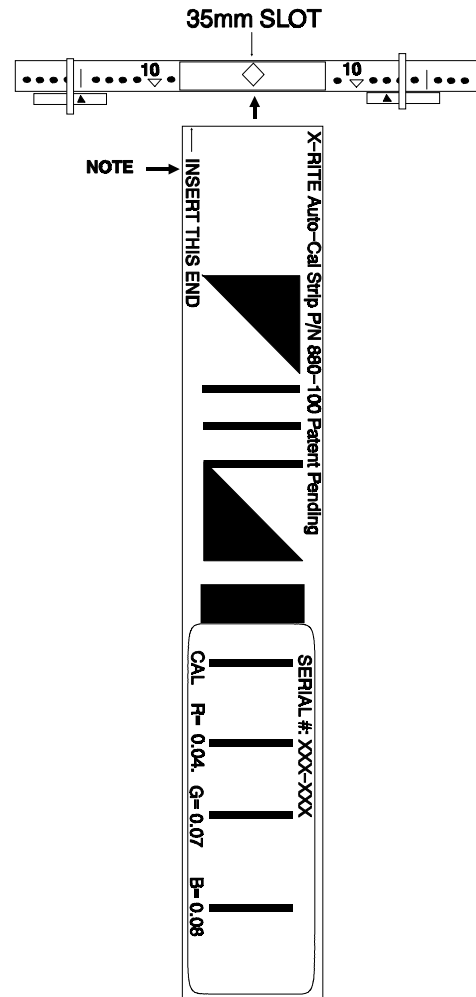

Continued

Manual Calibration - continued

Step 7 - "**READING**" is momentarily displayed. Calibration is finished and the calibration density values are momentarily displayed. The instrument will automatically return to the Channel Menu.

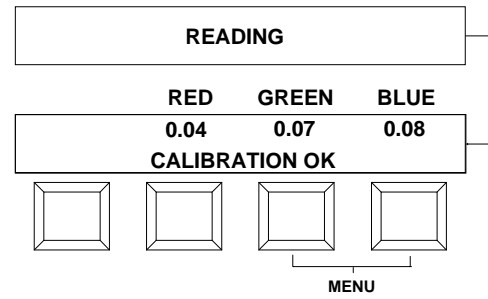

12.3. Frequency of Calibration

Under normal operating conditions, the instrument should be calibrated once a week or when instrument displays a message regarding calibration.

13.

Advanced Features

The advanced features should only be used after you have familiarized yourself with the complete operation of the densitometer.

13.1. Delete Operation

The delete function allows individual measurements in a channel to be erased, or the reference and all measurements in a channel to be erased at once.

Step 1 - At Channel Menu level, repeatedly press [p#] until "p5" is displayed. Then press [edit].

Step 2 - Press [del] to activate the delete function.

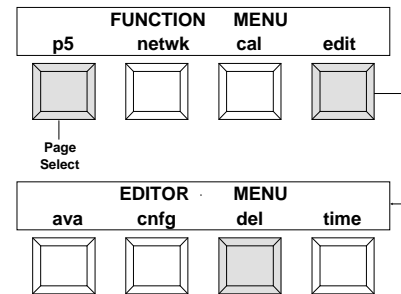

Deleting Individual Measurements

- Press channel select key to select channel.
- Select the desired strip measured (date & time) by pressing [<] to go backward or [>] to go forward in time.
- Press [<] and [>] together to delete displayed measurement.
- Press the two keys labeled "MENU" to exit out of delete function.

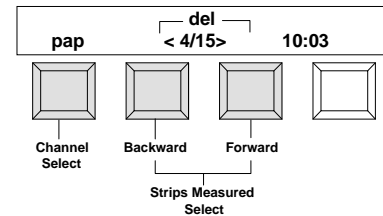

Deleting All Measurements

- Press channel select key to select channel.
- Press [>] repeatedly until "ALL DATA" is displayed.
- Press [<] and [>] together to delete all data in the channel.
- Press the two keys labeled "MENU" to exit out of delete function.

☞ If you do not want to delete all the data, press [<].
 If there is no measurement in a particular channel, "<-/--> --:--" will display in place of date and time.
 "CHANNEL IS EMPTY" will display when trying to delete from a channel with no measurements.

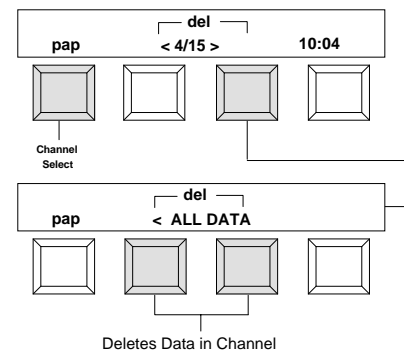

13.2. 881/882 Network

Refer to the X-Rite 881/882 Network Installation/Operation Manual (P/N 881-503).

14.

Measuring an Internegative (882 only)

The 882 allows measurements of internegatives. It will optional compute the changes in exposure and filter pack necessary to balance the internegative using the Density Difference method.

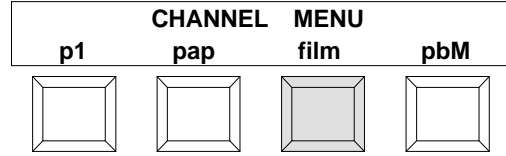

Step 1 - Press **[film]**.

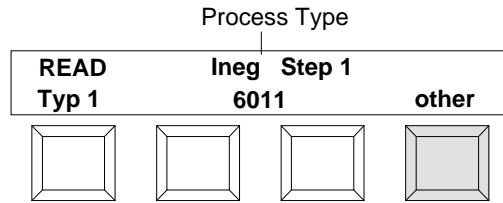

Step 2 - Press **[other]** until "Ineg Step 1" is displayed.

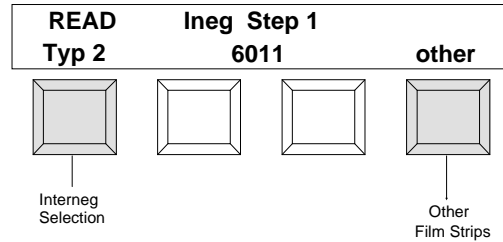

Step 3 - Select the interneg type (see Section 2 for type definition).

Each depression of the **[type]** key will alternate between "type 1" and "type 2" (for this example "type 2" is selected).

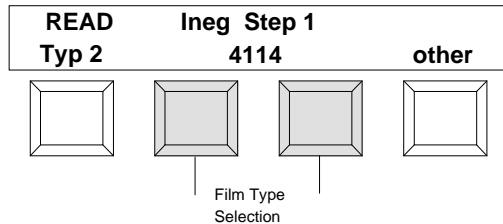

Step 4 - Select interneg film type.

Press either center key to select the film type. Select "6011" if you are using film similar to Kodak 6011 or 4112 Interneg film. Select "4114" if you are using film similar to Kodak 4114.

Step 5 - Insert strip into the 35mm slot (step 1 inserted first) until it rests against the drive rollers.

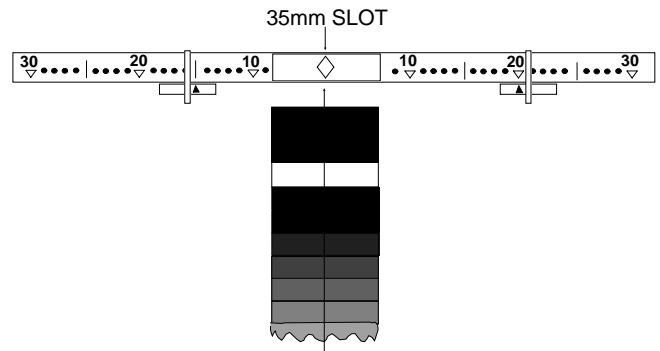

Continued

Measuring an Internegative - continued

Step 6 - When the reading is completed, the display will indicate which step pair will be used on subsequent calculations.

- Pressing the **[view]** key allows viewing of density difference numbers (refer to Section 14.1).
- Pressing the **[+Step-]** key allows viewing of the individual steps on the strip (refer to Section 14.2).
- Pressing the **[auto]** key performs filter pack and exposure calculations automatically (refer to Section 14.3).

☞ If the strip is severely over exposed, the warning message "**STRIP TOO FAR OVEREXPOSED**" will appear briefly. You will then be allowed to view the individual steps using **[+]** or **[-]** step keys, but will not be able to use the view and auto functions. If this happens, reduce your exposure by three or four stops and try another strip.

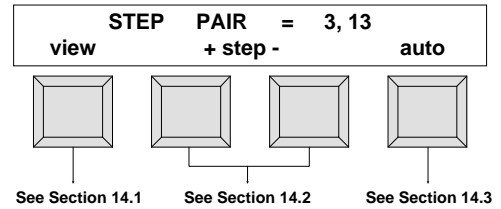

14.1 View (continued from Step 5 in Section 14)

The View function allows you to view the density difference values and recommended filter pack changes. Density difference values are calculated by simply subtracting the density values of the higher numbered step from the densities of the lower numbered step. These are used to look up your filter pack changes from the table.

Step 6 - Press **[Δfp]** key to get the filter pack changes from the internal table and display them.

☞ These numbers are changes (indicated by the Greek letter Δ) and should be added to the filter pack which was used for exposing this internegative.

Step 7 - Press **[Δden]** key to display the density difference values again.

Step 8 - Press **[exit]** to return to the Step Pair Menu so that further viewing or calculations can be performed.

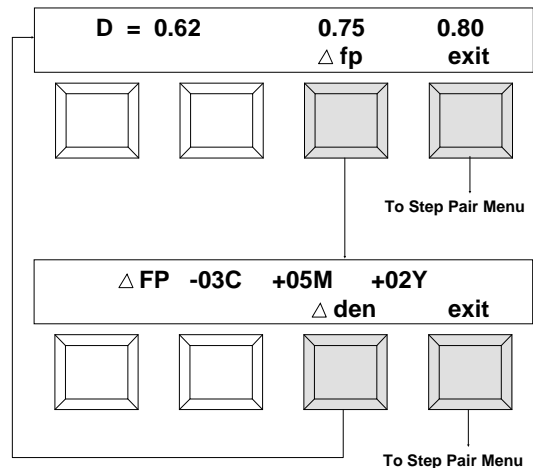

14.2 +Step- (continued from Step 5 in Section 14)

The +Step- function allows viewing of the individual steps on the strip.

Step 6 - Press either the **[+]** or **[-]** key to view data on each step of the internegative.

- **[+]** increments to the next step (step 21 will advance to step 1).
- **[-]** decrements to the next step (step 1 will advance to step 21).

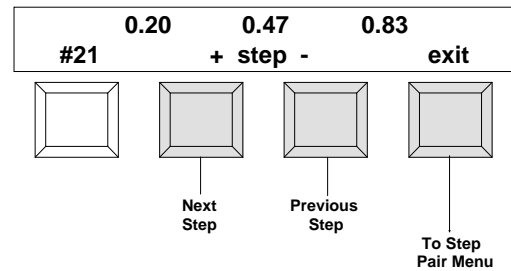

Step 7 - Press **[exit]** to return to the Step Pair Menu so that further viewing or calculations can be performed.

For "Type 1" internegatives (4 x 5 format), all of the even numbered steps are computed internally using a curve fitting algorithm because the actual internegative contains only the odd numbered steps.

14.3 Auto (continued from Step 5 Section 14)

The Auto function initiates the automatic exposure and filter pack compensation.

Step 6 - "Enter Starting Filter Pack..." is momentarily displayed. Enter the values of the filter pack used to make this internegative.

- **[↑]** increases the value marked by cursor.
- **[↓]** decreases the value marked by cursor.
- **[→]** moves the cursor to the next position.

Press **[cont]** when finished.

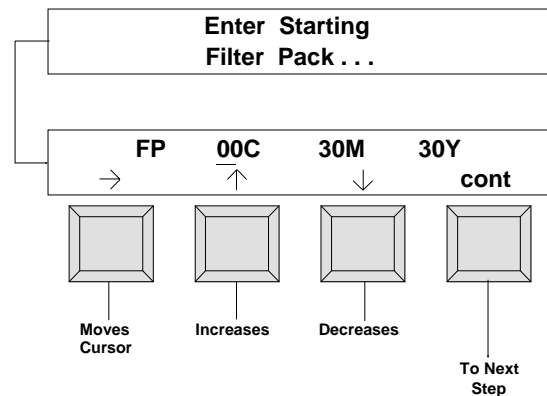

Step 7 - "Enter Exposure" is momentarily displayed. Enter your exposure time and aperture.

The "f" stop values increase or decrease in 1/6 stop steps and values can range from f/4.0 to f/32.0.

- **[↑]** increases the value marked by cursor.
- **[↓]** decreases the value marked by cursor.
- **[→]** moves the cursor to the next position.

Press **[cont]** when finished.

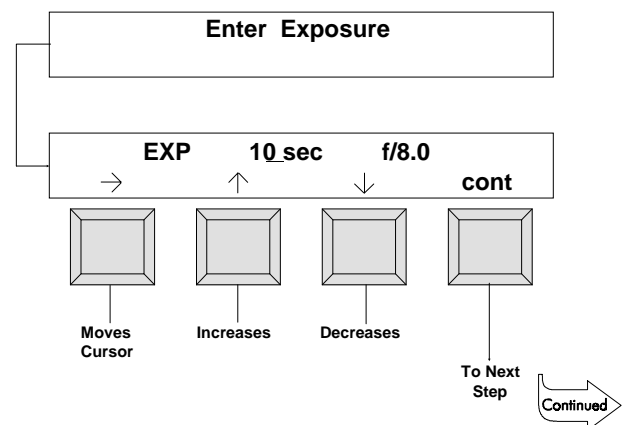

Auto - continued

Step 8 - The display now indicates suggested changes to your filter pack.

The numbers displayed are changes (indicated by "Δ") and should be added to the filter pack which was used to expose this internegative.

Press [Δoff] to turn the "change mode" off and view "absolute" filter pack values. Absolute values are the addition of your starting filter pack (entered earlier) to the changed values.

These values are adjusted to remove any neutral density. Therefore, one of these values (usually cyan) will always be zero. These values constitute your new filter pack which should be used for subsequent exposures.

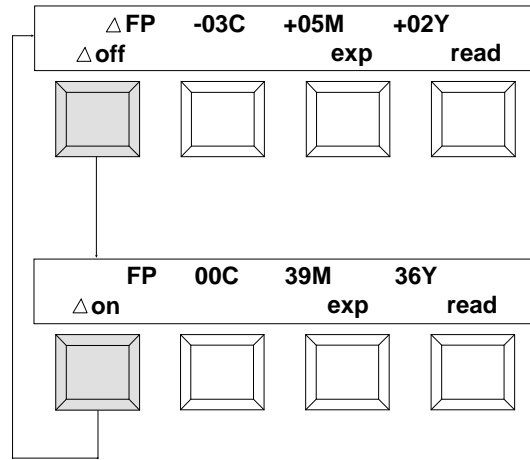

Step 9 - Press [exp] to display the suggested exposure.

Any neutral density adjustments to the filter pack will affect exposure as well. To avoid reciprocity problems, exposure time is held within 1/2 stop of your starting exposure time. This will sometimes cause an aperture change if the calculated exposure time adjustment is greater than 1/2 stop.

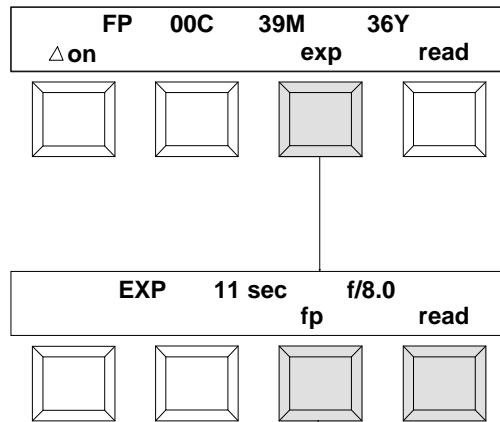

Step 10 - Press the [read] key to measure another internegative. The entire procedure described is repeated except that the exposure and filter pack values you have just viewed will be used as the starting values.

Step 11 - Press the two keys labeled "MENU" to exit out of the interneg function.

Since internegatives are a setup tool rather than a process control tool, any internegatives read are not stored in channel memory. Data that is currently stored in the channel memory is not destroyed.

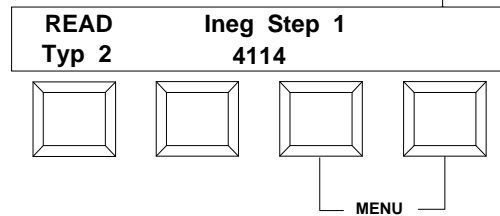

15.

General Maintenance

Important! Before proceeding with the following troubleshooting chart:

- Make sure strip being measured has been properly inserted and is free of smudges, scratches, and blemishes.
- Make sure the unit has been properly calibrated.
- Make sure that strips and the unit are free of dust and lint (see Sec. 15.2).
- If a wrong reading problem exists, recalibrate unit and recheck problem.

15.1. Troubleshooting Chart

PROBLEM	CAUSE	SOLUTION
Reflection measurement incorrect.	Unit needs calibration.	Recalibrate unit.
	Reflection cal strip dirty or bad.	Clean reflection cal strip or replace if bad.
	Read lamp weak.	Replace read lamp.*
Transmission measurement incorrect.	Unit needs calibration.	Recalibrate unit.
	Read lamp weak.	Replace read lamp.*
Transmission and Reflection measurements incorrect.	Unit needs calibration.	Recalibrate unit.
	Read lamp weak.	Replace read lamp.*
Measurements drift.	Unit needs calibration.	Recalibrate unit.
	Read lamp weak.	Replace read lamp.*
Unit will not calibrate.	Dirty (fingerprints) or bad cal strip.	Clean or replace cal strip.
Read lamp not working.	Read lamp open.	Replace read lamp.*
Measurements unrepeatable/incorrect.	Film/paper misaligned.	Reinsert strip.
	Film/paper has blemishes or scratch.	Use different strip.
	Reflection optics loose.	Plug reflection optics in place.
"INVALID READING", "UNRECOGNIZABLE STRIP", or "BUFFER OVERFLOW" message displays after measurement.	See Appendix, Sec A1.	See Appendix, Sec. A1.

* The instrument has a failure monitor that in most cases will automatically indicate when the lamp needs replacement.

15.2. Optics Cleaning

To remove any dust and lint from the optics and drive wheel assembly, follow the procedure shown approximately once a week.

Step 1 - Insert tube from the canned air into slip insertion slot (on front of unit). Make sure the air is clean and free of moisture.

Step 2 - With back and forth motion spray air into insertion slot from one end to the other. Do this several times. This should remove any accumulated dust and lint.

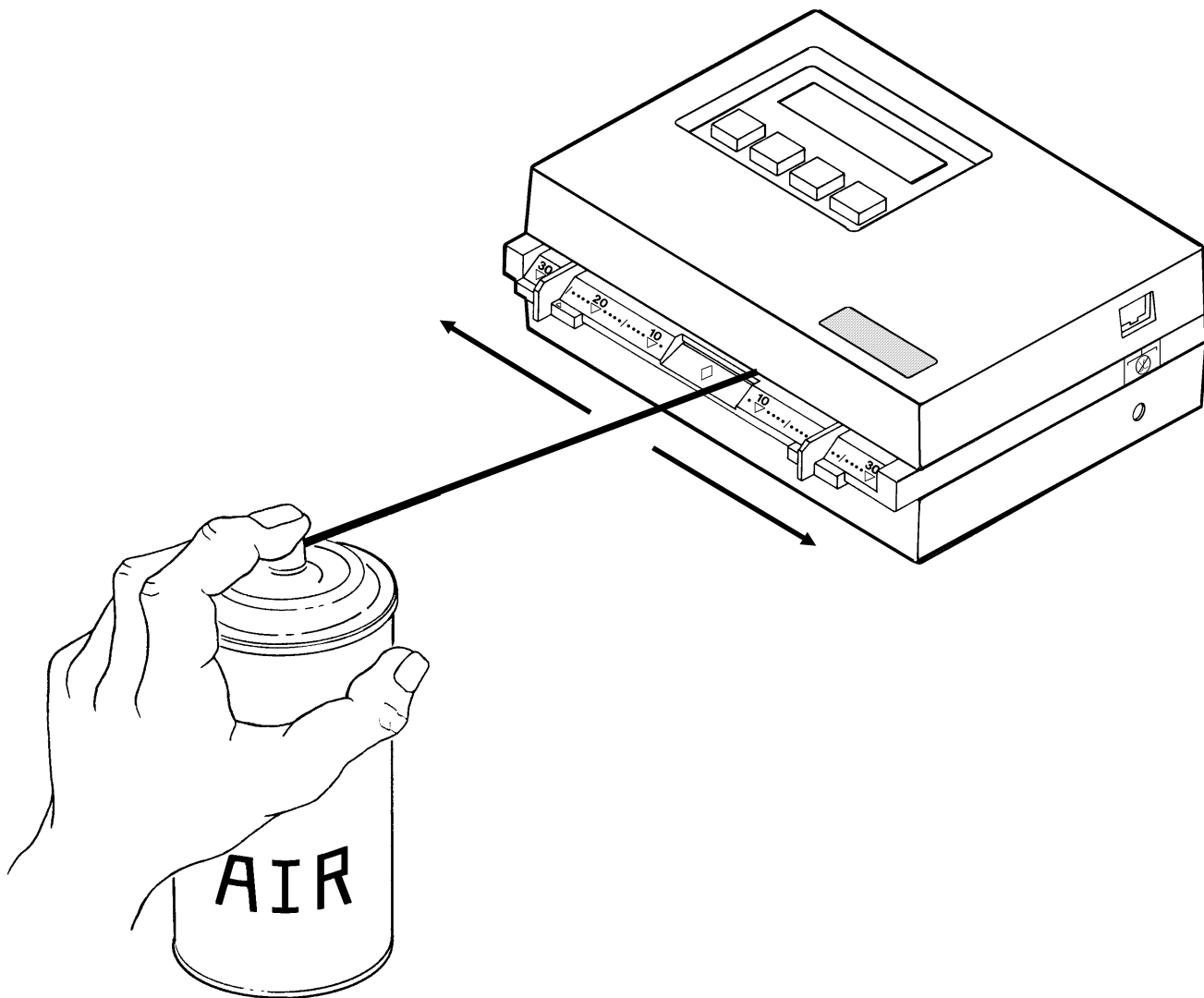

15.3. Read Lamp Replacement (P/N 880-07)

Step 1 - Remove four screws [2] securing the bottom cover [3] with a phillips-head screwdriver. Leave bottom cover [3] on unit.

Step 2 - Holding top [1] and bottom [3] covers in place, turn unit over so it rests on the bottom cover [3]. Remove top cover [1].

Step 3 - Locate optics assembly [4] and remove screw and washer [5] in the middle of lamp assembly P.C.B. [6].

Step 4 - Lift out old lamp assembly [6] and discard.

Step 5 - Install new lamp assembly [6] by carefully inserting lamp [6] into housing [7] and lamp pins [8] into lamp connector. Press down gently to make sure connector pins [8] are properly seated.

Step 6 - Secure lamp screw and washer [5] in place.

Step 7 - Carefully clean any dust or plastic chips off circuit board and top cover [1] using moisture free compressed air. Place top cover back on instrument.

Step 8 - Holding top and bottom covers in place, turn unit over so that it rests on top cover [1].

Step 9 - Remove bottom cover [3]. Clean circuit board and bottom cover [3] with compressed air, then place bottom cover [3] back on instrument.

Step 10 - Secure bottom cover [3] to instrument with four screws [2] using a phillips-head screwdriver.

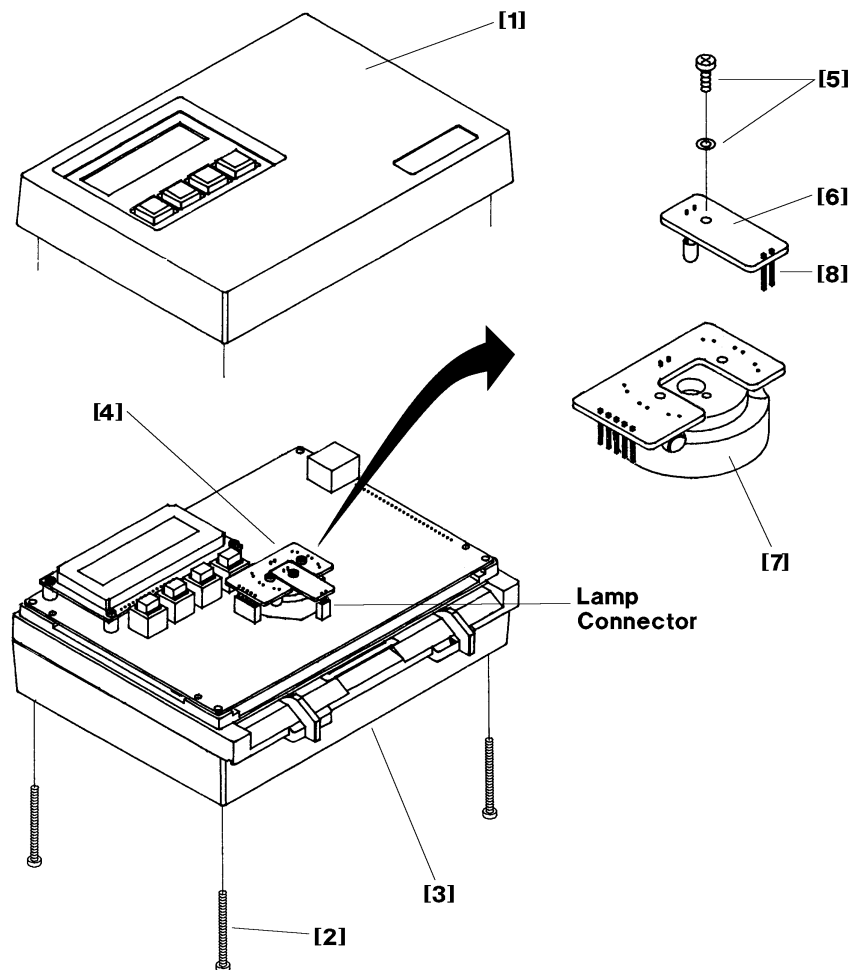

A.

Appendix

A.1. Error Messages

MESSAGE	REASON	POSSIBLE CAUSE	SOLUTION
INVALID READING PLEASE RE-READ! or UNRECOGNIZABLE STRIP or BUFFER OVERFLOW (During measurement)	Unit did not recognize strip.	Wrong strip selection.	Select correct format.
		Strip did not have a 1-1/8" leader before first target.	Use strip with leader or refer to the Control Strip & Balance Print Format Guide, Sec. 4 for leaderless strip insertion.
		Strip not inserted in the correct direction.	Refer to Control Strip & Balance Print Format Guide, Sec. 1 for strip insertion direction.
		Unit needs calibration.	Calibrate unit, see Sec. 12.
		Measurement region not aligned with center diamond, or strip not tracking properly.	Make sure measurement patches are centered with diamond and center line. Usually setting the paper guides to the numbers indicated on the display will take care of tracking problem. Make sure strip feeds straight through unit and does not curve toward one side.
		One or more measurement patches are cloudy, have excessive gradients, or have flecks.	Process and then measure a new strip.
		NOTE: If first read causes invalid error message try re-reading strip again. Measurement tolerances across the patch are opened slightly on second read.	
	Motor drive roller slip-page due to restraint or obstruction, or contamination of rollers from reading wet strips.	Remove restraint/obstruction or dry drive rollers with air.	
	Lamp failure (weak or bad).	Perform transmission calibration to test lamp, see Sec. 12.	
A-LIMIT EXCEEDED (During measurement)	Strip measured exceeds Action limit.	Computed values minus aims, are greater than the calculated Action limit.	Consult the manufacturers processor manual.



Error Messages - continued

MESSAGE	REASON	POSSIBLE CAUSE	SOLUTION
C-LIMIT EXCEEDED (During measurement)	Strip measured exceeds Control limit.	Computed values minus aims, are greater than the calculated Control limit.	Consult the manufacturers processor manual.
S-LIMIT EXCEEDED (During Measurement)	Strip measured exceeds Color spread limit.	R,G,B values are not remaining proportional to each other.	Consult the manufacturers processor manual.
UNRECOGNIZABLE AUTO CAL STRIP! (During reflection calibration)	Unit did not recognize cal strip inserted.	Strip inserted in backwards or upside-down.	Insert strip correctly, see Sec. 12.
		Cal strip is dirty.	Clean cal strip, see Sec. 12.
STRIP RESTRAINED RE-INSERT STRIP! (During reflection calibration)	Cal strip did not feed consistently.	Strip path is blocked by debris keeping cal strip from feeding properly.	Clean strip path, see Sec. 15.2
		Motor drive roller slip-page due to restraint or obstruction, or contamination of rollers from reading wet strips.	Remove restraint/obstruction or dry drive rollers with air. If problem persists, return unit for service.
WARNING MOTOR ERROR! (During reflection calibration)	Unit senses motor abnormality.	Strip was pulled out from back during calibration.	Do Not pull on strip during measurement.
		Motor brush wear.	Return unit for service.
		NOTE: If motor error message constantly displays, unit should be returned for proper service.	
PRESET MEMORY PLEASE CALIBRATE (During power-up)	Memory data detected in unit is not valid.		Recalibrate unit, see Sec. 12.
WARNING LAMP MARGINAL! (During transmission calibration)	Lamp output is less than 50% of its peak intensity (but still able to read).	Lamp has aged close to end of its useful life.	Order new lamp - replace at convenient time.
WARNING REPLACE LAMP! (During transmission calibration)	Lamp output is less than required intensity. Measurement accuracy of unit is questionable at this point.	Useful lamp life has expired.	Replace lamp immediately, see Sec. 15.3.

A.2. Term Abbreviations

ALF	Automatic Line Feed
ALL	Strip is one pass and may be read in either direction (strip measurement mode)
Avg	Average
aux 1 thru aux 3	Auxiliary 1 thru Auxiliary 3
ava.	Aim Value Adjustments
AXMT	Automatic Transmit
baud	Varies unit of data transmission speed.
BLK	Black patch must be read first (strip measurement mode)
cal	Calibration
chan.	Channel
c:I/O#1	Copal, I/O #1
c:I/O#2	Copal, I/O #2
cnfg	Configuration
COMP	Compact
CTS	Clear to Send
CYN	Cyan patch must be read first (strip measurement mode)
del	Delete
DEL	Delay (in configuration)
DEV	Deviation
DPT	Decimal Point
edit.	Editing
f:TECOM	Fuji, Tecom System
HD	High Density patch must be read first (strip measurement mode)
k:C.A.P.	Kodak, Create a Print
k:SYS ² 5→ ⁷ 5	Kodak, Systems 25 thru 75
k:TNetA	Kodak, Technet A
k:TNetXT	Kodak, Technet XT
LANG	Language
MIN	Minimum Density patch must be read first (strip measurement mode)
netwk	Network
NEW-1 thru NEW-3	New Strip #1 thru New Strip #3
NRM	Normal patch must be read first (strip measurement mode)
NUO 1-Pass	Normal/Under/Over in 1 pass
OLD-1 thru OLD-3	Old Strip #1 thru Old Strip #3
pap	Paper
pbM	Printer Balance, Master Channel
pb1 thru pb3	Printer Balance #1 thru Printer Balance #3
PIN5	Pin5 of RS232 port can be set to Off, Busy, or CTS
p1 thru p5	Page #1 thru Page #5
p2a thru p2d	Page #2a thru Page #2d
Q.C.	Quality Control



Term Abbreviations - continued

RCI	Remote Control Interface
ref	Reference
SPRD-SHT	Spread Sheet
TTL	Time tag log
UND.	Under patch must be read first (strip measurement mode)
UNO 1-Pass	Under/Normal/Over in 1 pass
UNO 3-Pass	Under/Normal/Over in 3 passes
xmit	Transmit
YEL	Yellow patch must be read first (strip measurement mode)
↑	Increase amount
↓	Decrease amount
→	Advances cursor
<	Changes display to previous measurements
>	Advances display to next measurement

A.3. Unit Configuration Definition

The configuration setup contains two pages: Page 1 (**LANG, TONE, & NET**) and Page 2 (**I/O Presets**). The factory preset and configuration explanation is as follows:

PAGE 1: LANG [ENG], TONE [LOUD], & NET [OUT]

PAGE 2 : IO PRESET [CUSTOM]

Page 2a: RCI [OFF], PIN5 [OFF], & XON [OFF]

Page 2b: DPT [ON], COMP [ON], & ALF [ON]

Page 2c: DEL [OFF], AXMT [OFF], & REF [ON]

Page 2d: BAUD [1200] & LOCK [OFF]

PAGE 1

- **LANG (Languages)**

Language option not installed at this time.

- **TONE Off/Soft/Loud**

Allows the tone volume to be set to Off, Soft, or Loud.

- **NET (Network) OFF/OUT/IN/I&O**

Enables the 881 to automatically send and receive data via the modem at a predetermined time selected by the QC computer. Setting NET to OUT, IN, or I&O also enables "page 6" of the main menu which contains the log buffer functions.

NET = OFF: Disables the instrument from automatically sending or receiving data.

NET = OUT: Enables automatic transmission of data from the 881 via the modem.

NET = IN: Enables automatic reception of data from the 881 via the modem.

NET = I&O: Enables automatic transmission and reception of data from the 881 via the modem.

PAGE 2

- **I/O Preset**

Determines the output that will be used, and will automatically select the proper configuration. Refer to the next page for a listing of available I/O Presets.

If I/O preset is set to "**CUSTOM**" all other parameters (i.e., baud, rci, etc.) will have to be set. If I/O preset is set to anything else (i.e., k:TNetA, k:TNetXT, etc.) all necessary parameters will automatically be set.

Page 2a

- **RCI (Remote Control Interface) On/Off/TTL**

Enables or disables the ability to externally control the unit via the serial I/O port. RCI also selects the method in which the densitometer receives data into the log buffer. Option are as follows:

RCI = ON: Data is received via rci command.

RCI = TTL: Any data coming into the serial port is automatically placed in the log buffer.

RCI = OFF: Places the densitometer into a receive mode at which time the instrument can receive data.

- **PIN5 Off/CTS/Busy**

Determines the status of the handshaking input on Pin5 of the RS232 I/O port. Pin5 may be interpreted as BUSY, CTS (clear to send), or set to OFF (i.e., ignored).

- **XON On/Off**

When set to On (XON), enables bidirectional transmit On/Off protocol. When set to Off (xon), the unit ignores XON/XOFF codes. Note: Usage limited to output at this point.

Page 2b

- **DPT (Decimal Point) On/Off**

Enables or disables the decimal point during print-out. When set to On (DPT), the decimal point will be included in the data. When set to Off (dpt), no decimal point will be output with the data.



Unit Configuration Definition - continued

-COMP (Compact) On/Off

Varies the output format of the I/O port. When set to On (COMP), a space will be transmitted after each of the three color's (R,G,B) data values and then the delimiter. When set to Off (comp) each color's data value is delimited with a CR (or CR LF if ALF is enabled).

- ALF (Automatic Line Feed) On/Off

Enables or disables a line feed along with each carriage return of the output data.

Page 2c

- DEL (Delay) On/Off

Enables or disables a one second delay between each set of Red, Green, Blue density data sent out of the I/O port.

-AXMT (Automatic Transmit) On/Off

Enables or disables automatic transmission of information after a reading was taken.

-REF (Reference) On/Off

Enables or disables measured data from being compared to references during readings.

Page 2d

-BAUD (Rate) 110/300/600/1200/2400/4800/9600

Determines the output rate (characters per second) of the I/O port. Available outputs are: 110, 300, 600, 1200, 2400, 4800, & 9600.

-LOCK On/Off

Allows user to lock the configuration options to prevent inadvertent or unauthorized changes.

When a certain I/O preset is selected (other than CUSTOM) the necessary parameters (e.g., rci, baud, etc.) will automatically be setup. Below is a chart listing the parameters that are set for each I/O preset; the parameters that can and cannot be changed for each I/O preset; and the parameters that remain unaffected.

I/O PRESET	RCI	PIN5	XON	DPT	COMP	ALF	DEL	AXMT	REF	BAUD
REPORT	*	*	*	On(L)	On(L)	On(U)	Off(L)	Off(U)	On(U)	*
SPRD-SHT	*	*	*	*	Off(L)	*	*	On(L)	*	*
k:TNetA	Off(L)	Off(L)	Off(L)	Off(L)	On(L)	On(L)	On(L)	On(L)	Off(L)	300(L)
k:TNetXT	Off(L)	CTS(L)	Off(L)	Off(L)	On(L)	On(L)	Off(L)	On(L)	Off(L)	*
k:C.A.P.	Off(L)	CTS(U)	Off(L)	Off(U)	On(U)	On(U)	Off(L)	On(L)	*	9600(L)
k:SYS25-75	Off(L)	CTS(L)	Off(L)	Off(L)	On(L)	On(L)	Off(L)	On(L)	*	*
f:TECOM	Off(L)	Off(L)	Off(U)	Off(U)	Off(U)	Off(U)	Off(U)	On(U)	Off(L)	1200(U)
c:I/O#1	*	Off(L)	Off(L)	Off(U)	On(U)	On(U)	On(U)	On(L)	*	9600(L)
c:I/O#2	*	Off(U)	Off(U)	Off(U)	On(U)	On(U)	On(U)	On(U)	*	9600(U)
MITSY#1	Off(U)	Off(U)	Off(U)	Off(L)	Off(L)	Off(L)	Off(U)	On(U)	*	300(L)
MITSY#2	Off(U)	Off(U)	Off(U)	Off(L)	Off(L)	Off(L)	Off(U)	On(L)	Off(L)	300(U)
NORITSU	Off(L)	CTS(U)	Off(L)	Off(L)	On(L)	On(L)	Off(L)	On(L)	Off(L)	2400(U)
n:QSSnet	Off(U)	Off(U)	Off(U)	Off(U)	Off(U)	Off(U)	Off(U)	On(U)	Off(U)	2400(U)
n:Micro**	*	*	*	*	*	*	*	*	*	*
kn:Net	TTL(U)	Off(U)	Off(U)	Off(U)	On(U)	Off(U)	Off(U)	Off(U)	On(U)	2400(U)
a:LC2000	Off(U)	Off(U)	Off(U)	Off(U)	On(U)	On(U)	ON(U)	On(U)	Off(U)	1200(U)
CUSTOM	TTL(U)	Off(U)	Off(U)	On(U)	On(U)	On(U)	Off(U)	Off(U)	On(U)	1200(U)

U (unlocked) = Parameters that were automatically set during I/O preset selection, that **can be** changed.

L (locked) = Parameters that were automatically set during I/O preset selection, that **cannot** be changed.

* = Parameters that remain unchanged from previous settings, and **can be** changed.

k: = Kodak, **f:** = Fujii, **c:** = Copal, **kn:** = Konica, **n:** = Noritsu, **a:** = Agfa

**Setting the IO presets to "n:Micro" results in changes to the menu structure of the instrument with several menu items becoming unavailable.

A.4. Densitometer Specifications

Transmission Process Control

Film Width	35mm fixed slot or 1.4 - 6.0 inch adjustable
Measurement Speed	1.3 inches/second
881 Spectral Response	Status M
882 Spectral Response	Status A & M
Density Range	0 - 4.0D
Density Accuracy	+/- .02D (0-3.00D), +/- 1% (3.01-3.40D), +/- 3% (3.41-4.00D)
Density Repeatability	+/- .01D (0-3.00D), +/- .02D (3.01-3.40D), +/- 0.04D (3.41-4.00D)
Control Strip Measurement Area.....	0.375" (length) x 0.5" (wide) minimum

Reflection (paper) Process Control and Printer Balance

Paper Width	1.4 - 6.0 inches (adjustable slot)
Measurement Speed	1.3 inches/second
Control Strip Measurement Area.....	0.375" (length) x 0.5" (wide) minimum
Printer Balance Measuring Area075" diameter minimum
Spectral Response	Status A
Density Range	0 - 2.5D
Density Accuracy	+/- .02D
Density Repeatability	+/- .01D

General Specifications

A.C. Adaptor (115VAC - P/N SE30-61) (230VAC - P/N SE30-62)	12VDC @ 0.7amp
Dimensions	7.2" x 6.0" x 2.75" (182.8mm x 152.4mm x 69.8mm)

Specification and design subject to change without notice.

A.5. Accessory Items

X-Rite carries a variety of "DB" type adaptors and cables for interfacing your densitometer with a computer or printer. Ask you X-Rite Representative or call X-Rite, Inc to find out which adaptor or cable will best meet your requirements.

- 880 Series Interface ManualP/N 880-506
- 881 Modem Interface KitP/N 881-57



X-Rite, Incorporated—World Headquarters

3100 44th Street S.W. • Grandville, Michigan 49418 • USA

www.x-rite.com

Toll-Free U.S. Numbers

Tel: 1-888-826-3044 • Fax: 1-888-826-3045

Toll-Free International Numbers

Tel: 1-888-826-3039 • Fax: 1-888-826-3041

X-Rite GmbH

Stollwerckstraße 32 • 51149 Köln o Germany

Tel: (49) 2203-91450 • Fax: (49) 2203-914519

X-Rite GmbH

Sochorova 705 • CZ-682 • 11 Vyskov o Czech Republic

Tel: (42) 0507-328197 • Fax: (42) 0507-328138

X-Rite Asia Pacific Ltd.

Room 808-10 • Kornhill Metro Tower 1 Kornhill Road • Quarry Bay

Hong Kong • Tel: (852) 2-568-6283 • Fax: (852) 2-885-8610

X-Rite Ltd.

The Acumen Centre • First Avenue

Poynton, Cheshire • England

Tel: 9-011-44-0-1625-871100 • Fax: 9-011-44-0-1625-871444

X-Rite Méditerranée

Parc du moulin de Massy • 35, rue du Saule Trapu • 91300 Massy • France

Tel: 33-1-69.53.66.20 • FAX 33-1-69.53.00.52