

X-Rite® 880

Automatic Strip Reader Color Photographic Densitometer

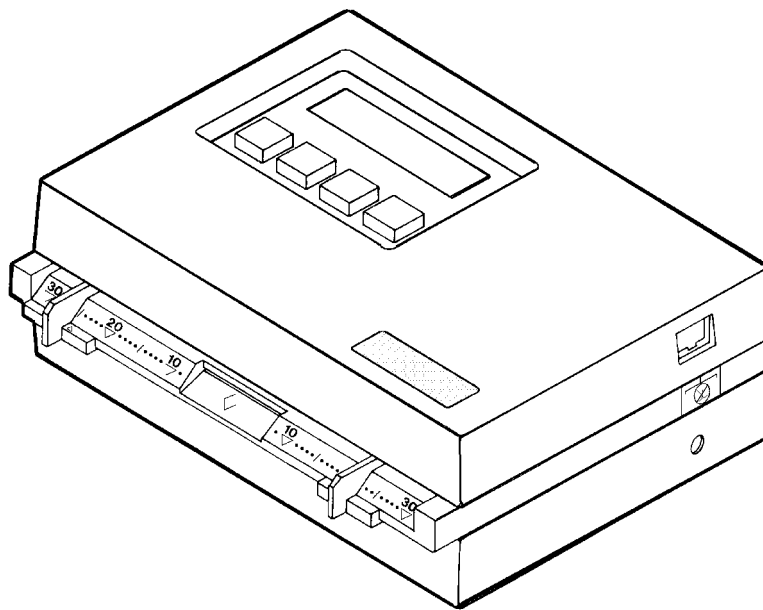

Operation Manual

CAUTION: Operational hazard exists if AC adaptor other than X-Rite SE30-61 (115V) or SE30-62 (230V) is used.

VORSICHT: Es besteht Betriebsgefahr bei der Verwendung von einem Adapter außer X-Rite SE30-61 (115 U) oder SE30-62 (230 U).

AVISO: No use otro adaptador C.A. que no sea la pieza X-Rite SE30-61 (115V) o SE30-62 (230V), por el riesgo de mal funcionamiento del equipo.

ATTENTION: Ne pas utiliser un autre adaptateur que la pièce X-Rite SE30-61 (115V) ou SE30-62 (230V).

AVVISO: Non usare un altro adattatore C.A. che non è del pezzo X-Rite SE30-61 (115V) o SE30-62 (230V), per il rischio di malfunzionamento dell'apparecchio.

WARNING: Shielded interface cables must be used in order to maintain compliance with the desired FCC and European emission requirements.

ACHTUNG: Um das Produkt innerhalb der FCC (Vereinigten Staaten) und den europäischen Emissions-Richtlinien zu halten, müssen geschirmte Schnittstellenkabel verwendet werden.

AVISO: Para satisfacer las deseadas regulaciones de emisión para Europa y el FCC, se debe utilizar los cables de interfaz protegidos contra las interferencias electromagnéticas.

AVERTISSEMENT: On ne doit utiliser que des câbles d'interface armés avec ce produit de conformer aux règlements d'émission européens et de FCC dans les Etats-Unis.

AVVISO: Per conformare con i desiderati regolamentazioni di emissione per Europa ed il FCC, utilizzare i cavi d'interfaccia protetti contro l'interferenze elettromagnetiche.

The Manufacturer: X-Rite, Incorporated
Der Hersteller: 3100 44th Street, S.W.
El fabricante: Grandville, Michigan 49418
Le fabricant:
Il fabbricante:

Declares that: Densitometer
gibt bekannt: 880
advierde que:
avertit que:
avverte che:

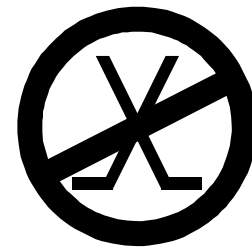

is not intended to be connected to a public telecommunications network.
an ein öffentliches Telekommunikations-Netzwerk nicht angeschlossen werden soll.
no debe ser conectado a redes de telecomunicaciones públicas.
ne doit pas être relié à un réseau de télécommunications publique.
non deve essere connesso a reti di telecomunicazioni pubblici.

FCC

This equipment has been tested and found to comply with the limits for a Class A digital device, pursuant to Part 15 of the FCC Rules. These limits are designed to provide reasonable protection against harmful interference when the equipment is operated in a commercial environment. This equipment generates, uses, and can radiate radio frequency energy and, if not installed and used in accordance with the instruction manual, may cause harmful interference to radio communications. Operation of this equipment in a residential area is likely to cause harmful interference in which case the user will be required to correct the interference at his own expense.

Canada

This Class A digital apparatus meets all requirements of the Canadian Interference-Causing Equipment Regulations.

Cet appareil numérique de la classe A respecte toutes les exigences du Règlement sur le matériel brouilleur du Canada.

Congratulations!

We at X-Rite, Incorporated are proud to present you with the X-Rite 880 Auto Strip Reading, Color Photographic Densitometer. This instrument represents the very latest in microcontrollers, integrated circuits, optics, and display technology. As a result, your X-Rite instrument is a rugged and reliable instrument whose performance and design exhibit the qualities of a finely engineered instrument, which is not surpassed.

To fully appreciate and protect your investment, we suggest that you take the necessary time to read and fully understand this manual. As always, X-Rite stands behind your instrument with a full one year limited warranty and a dedicated service organization. If the need arises, please don't hesitate to call us.

Thank you for your trust and confidence.

Chairman and CEO
Ted Thompson

Proprietary Notice

The information contained in this manual is derived from patent and proprietary data from X-Rite, Incorporated. This manual has been prepared expressly for the purpose of assisting operation and maintenance personnel in their use and general maintenance of the instrument.

Publication of this information does not imply any rights to reproduce or use it for purposes other than installing, operating, or maintaining the equipment described herein. No part of this manual may be reproduced, transcribed, stored in a retrieval system, or translated into any language or computer language, in any form or by any means: electronic, magnetic, mechanical, optical, manual, or otherwise; without the prior written permission of an authorized officer of X-Rite, Incorporated. These provisions are intended to state all of the rights and responsibilities between X-Rite, Incorporated and customer. They take place of and supersede all warranties, expressed or implied, and whether of merchantability, fitness or otherwise. The remedies contained in this operation manual are exclusive. Customer and X-Rite, Incorporated waive all other remedies, including but not limited to consequential damages.

This instrument is covered by the following U.S. and foreign patents: #4,591,978; #5,062,714; #5,118,183; and other patents pending.

Copyright © 1989 by X-Rite, Incorporated "ALL RIGHTS RESERVED"

Limited Warranty

X-Rite, Incorporated warrants each unit manufactured to be free of defects in material and workmanship for a period of twelve months. THERE ARE NO WARRANTIES OF MERCHANTABILITY OR FITNESS. THIS WARRANTY OBLIGATION IS LIMITED TO SERVICING THE UNIT RETURNED TO X-RITE, INCORPORATED FOR THAT PURPOSE AND EXCLUDES THE LAMP. The unit shall be returned with transportation charges prepaid. If the fault has been caused by misuse or abnormal conditions of operations, repairs will be billed at a nominal cost. In this case, an estimate will be submitted before work is started, if requested. Always include serial number in any correspondence concerning the unit. The serial number is located on the bottom of the unit.

X-Rite, Incorporated offers a repair program for instruments out of warranty. For more information, contact X-Rite, Instrument Services Department.

This agreement shall be interpreted in accordance with the laws of the State of Michigan and jurisdiction and venue shall lie with the courts of Michigan as selected by X-Rite, Incorporated.

X-Rite® is a registered trademark of X-Rite, Incorporated.

Agfa-Gevaert®, Fuji®, Eastman Kodak®, Mitsubishi®, Konica®, Copal®, Noritsu® and Champion Photochemistry® are registered trademarks. All other logos, product names, and trademarks mentioned are the property of their respective manufacturers.

Table of Contents

1. Packaging Check List	1
2. General Description	3
3. User Interface	4
4. Applying Power	6
5. Keyboard Functions	7
6. Configuring Your 880	8
7. Adjusting the Paper Guides	10
8. Taking Measurements	11
8.1 Measuring a Color Paper Strip	13
8.2 Measuring a Film Strip	15
8.3 Measuring a Printer Balance Strip	16
9. Viewing Data	17
10. Transmitting Data	18
11. Calibration	19
11.1 Auto Calibration	20
11.2 Correlating to Another Densitometer	21
11.3 Frequency of Calibration	23
12 Maintenance	24
12.1 Troubleshooting Chart	24
12.2 Optics Cleaning	25
12.3 Read Lamp Replacement	26
Appendix	27
A1 - Error Messages	27
A2 - Term Abbreviations	29
A3 - Unit Configuration Definition	30
A4 - Densitometer Specifications	32
A5 - Accessory Items	33

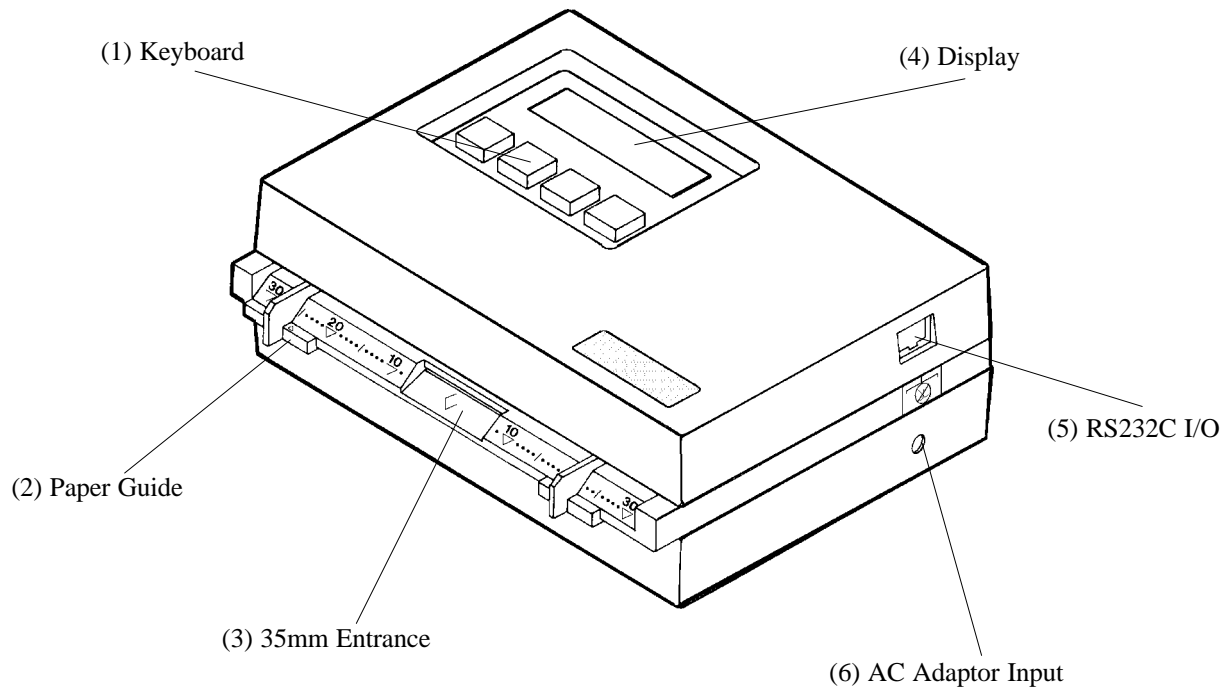

(1) **KEYBOARD** - Consists of four keys and is used for selecting control strip format (paper, film, & printer balance), viewing/transmitting data, and various mode functions.

(2) **PAPER GUIDE** - Used as an alignment guide when measuring control strips.

(3) **35mm ENTRANCE** - Used as an alignment guide when measuring 35mm film strips.

(4) **DISPLAY** - Used for displaying measurement information, messages, strip formats, etc.

(5) **RS-232C I/O** - Used for sending and receiving information from a computer or printer.

(6) **AC ADAPTOR** - Used to power the unit.

Getting Started

This section explains the necessary steps you should first take to properly setup and use your X-Rite 880 densitometer.



Make sure that the unit is not damaged and all the accessories are enclosed, read *Packaging Check List (Section 1)*.



Become familiar with the basic function of the 880, read *General Description (Section 2)*.



Become familiar with the typographical conventions, display functions, and general terms used in this manual, read *User Interface (Section 3)*.



Now it's time to power up your unit, read *Applying Power (Section 4)*.



Get acquainted with the keyboard and operating functions, read *Keyboard Functions (Section 5)*.



Set the configuration of the densitometer (tone, default, I/O parameters), read *Configuring Your 880 (Section 6)*.



See how to adjust the paper guides, read *Adjusting the Paper Guides (Section 7)*.



Process a control strip and then measure it, read *Taking Measurements (Section 8)*.



Learn how to view the density values of the strip you just measured, read *Viewing Data (Section 9)*.



Continue reading the remaining sections to find out how to transmit data and calibrate your unit.

1. Packaging Check List

After removing the instrument from the shipping carton, inspect for possible damage. If any damage is noted, contact the transportation company immediately. Do nothing more until the carrier's agent has inspected the damage.

If damage is not evident, check and make sure that all items are included (Refer to the parts list below, and the following page for the packaging illustration).

Your 880 Densitometer was packaged in a specially designed carton to assure against damage. If reshipment is necessary, the instrument should be packaged in the original carton. If the original carton is not available, a new one can be obtained from X-Rite, Incorporated. Refer to the packaging drawing on the following page.

15	1	1	SD01-41	CERTIFICATE OF CALIBRATION
14	-	-	NOT USED	
13	-	-	NOT USED	
12	1	1	880-602	CONTROL STRIP & BALANCE PRINT FORMAT GUIDE
11	1	1	SD65-13	PLASTIC BAG
10	-	1	SE30-62	AC/DC ADAPTOR, 230VAC 50/60HZ
	1	-	SE30-61	AC/DC ADAPTOR, 115VAC 50/60HZ
9	-	-	NOT USED	
8	1	1	SD01-10	IMPORTANT NOTICE
7	1	1	SD01-04	WARRANTY REGISTRATION FORM
6	1	1	880-100	AUTO CALIBRATION STRIP ASSY
5	1	1	880-500	OPERATORS MANUAL
4	1	1	SD68-10	PACKAGING ENVELOPE
3	1	1	SD65-07	PLASTIC BAG
2	2	2	SD200-880-06	CARTON INSERT
1	1	1	SD200-880-01	CARTON
ITEM	QTY-880	QTY-880X	PART NUMBER	DESCRIPTION
PARTS LIST				

PACKAGING ILLUSTRATION

SECTION 1

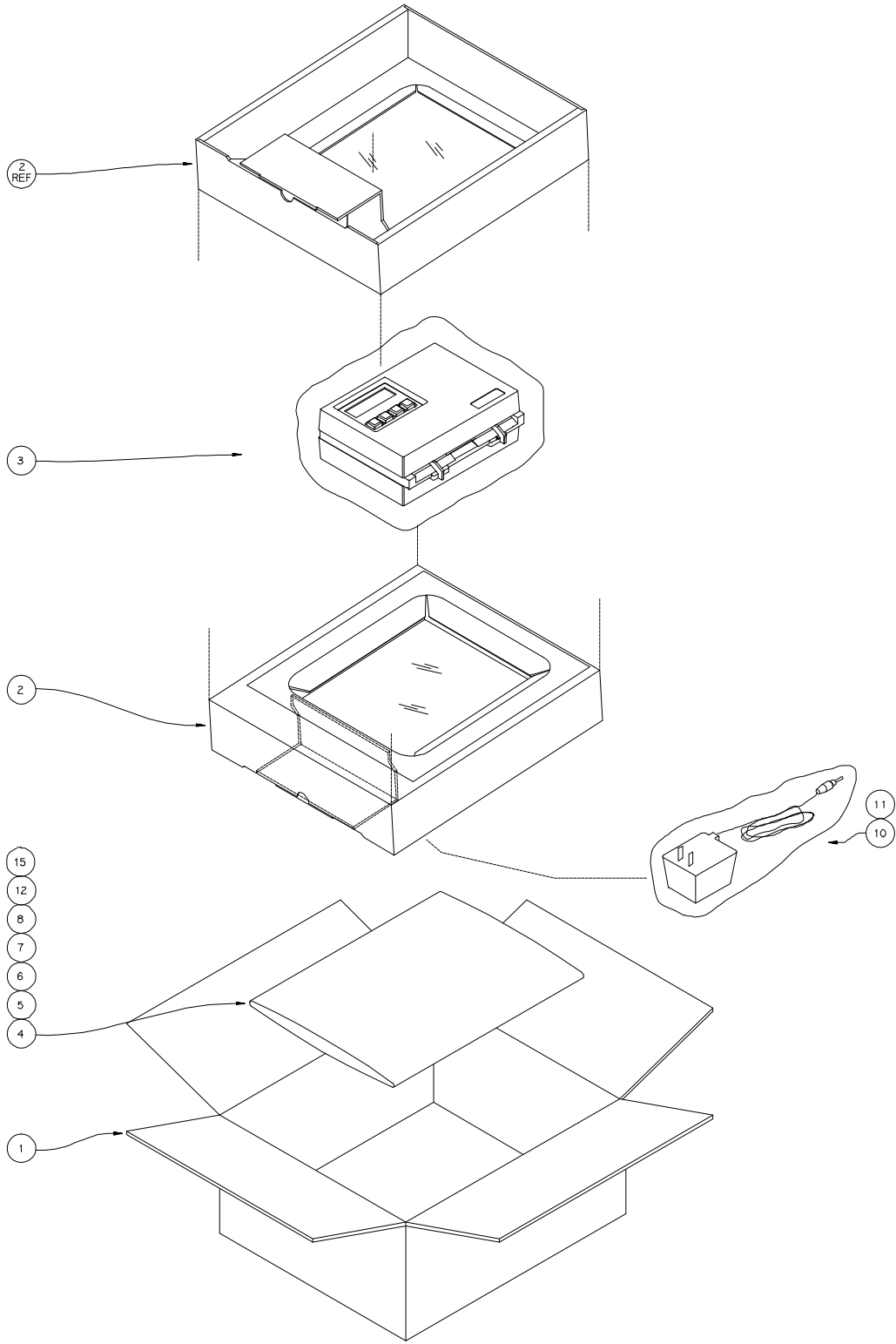

2.**General Description**

The X-Rite 880 is an automated instrument that will read film control strips, paper control strips, and printer balance strips. Simply insert strip into unit for motorized, automatic measurements.

The instrument automatically measures many types of control strips (ex., EP2, C41, RA-4, etc.), sorts the data for measured fields such as: HD, LD, & Stain; and then displays and simultaneously transmits the data to the minilab printer.

The strip formats are broken down into three **categories**:

- Paper (EP2, RA-4, CP-21, AP-92, R-3, P-3, etc.).
- Film (C-41, KBM, CN-16, etc.).
- Printer Balance (White Ringed Bull's-Eyes, Black Ringed Bull's-Eyes, Cropped Bull's-Eyes, etc.).



> See Strip Format Flow Chart in Section 5 for a complete listing of all the control strips supported by the 880.

The 880 will output a Red, Green, and Blue density value for each field (ex., Stain, Dmax, Dmin, etc.) measured. The only requirement is that the areas to be measured on the control strip are aligned to either the left side, right side, or center line of the strip, in a straight line format.

To accommodate the different size control strips, the 880 has an adjustable paper guide on each side of the control strip entrance. Adjustment is made by simply sliding the paper guides to the settings displayed for the strip selected.

The 880 communicates using the standard RS232C interface. If it is desired to remotely control the 880 you must use the RCI (Remote Control Interface) communication protocol discussed in the 880 Series RS-232 Interface Manual (available from X-Rite, P/N 880-506). The RCI feature is patented by X-Rite, Incorporated.

3. User Interface

This section will familiarize you with typographical conventions, display functions, and general terms used in this manual. Also, a listing of operational information.

- In most cases **UPPERCASE** letters in the display represent advisory information (i.e., functions, menu names, messages, warnings, etc.). The **lower-case** words and letters in the display represent key names or functions (i.e., pap, cal, yes, no, etc.), that can be modified by the keys.
- Keys that are shown as shaded will be the only keys that are active for a particular function.

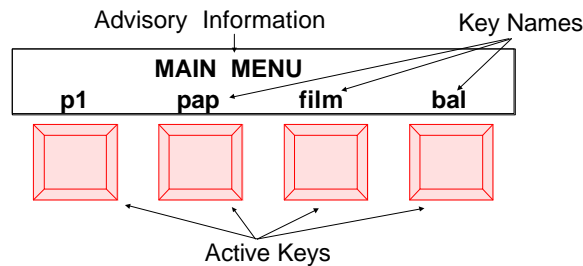

- In the text portion of this manual the 880 keys are shown with brackets on both sides and in bold face. Ex. **[pap]**, **[film]**, etc.
- Information that will appear in the display will be shown in the text with quotation marks on each side and in boldface. Ex. **"MAIN MENU"**
- During strip selection, a lowercase letter will be displayed next to the strip type to designate the manufacturer of the strip. They are as follows:
a: (Agfa-Gevaert[®]) **cp:** (Champion Photochemistry[®]) **f:** (Fuji[®]) **i:** (Ilford[®]) **k:** (Eastman Kodak[®])
m: (Mitsubishi[®])

Note: Konica[®] paper control strips do not have a designation letter.

- When a particular paper strip is selected, one or both guide settings positions displayed will blink. If only one guide setting is blinking, this indicates the guide that the strip will rest on first when inserting. In most cases this only occurs on a multi pass strip. On single pass strips both settings will blink.

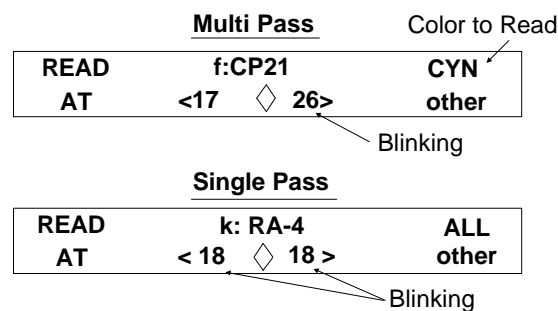

User Interface - continued

- A "hand symbol" indicates important notes and possible operations that need to be performed before normal operation.



- When a procedure is continued on the next page an "arrow symbol" will appear in the bottom right hand corner of the page.



IMPORTANT!

Operational Information:

- Due to the amount of variation in printer balance strips, there are no guide settings displayed in the printer balance categories.
- When inserting strips (with 30.5mm or more of leader), push in until it rests against the drive rollers. For proper leaderless strip insertion, see Control Strip & Balance Print Format Guide.
- When strip is initially inserted, there is a one second delay to allow time for proper alignment.
- A 16mm wide C41 control strip can not be measured due to the drive mechanism.
- The 880 will not measure creased strips.
- If the strip gets jammed in the unit, press the two keys labeled "**MENU.**" If this does not feed the strip out, pull strip out slowly from the front of unit.

4. Applying Power

To apply power to the unit, insert the AC adaptor plug into the unit, and then the transformer into the wall socket.

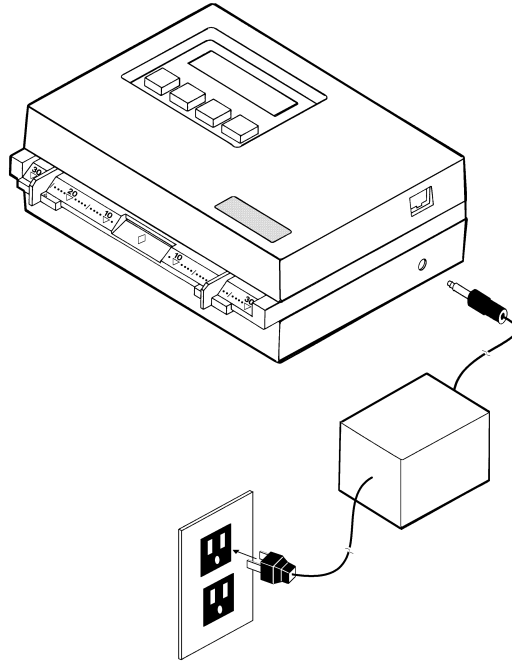

When power is applied, the 880 will perform a diagnostic procedure at initial power-up.

The MAIN MENU is contained in three pages. To advance through the pages press: **[p1]**, **[p2]**, and **[p3]**.

If you wish to return to page 1 of the MAIN MENU at **any** point in time, simultaneously press the two keys marked "MENU."

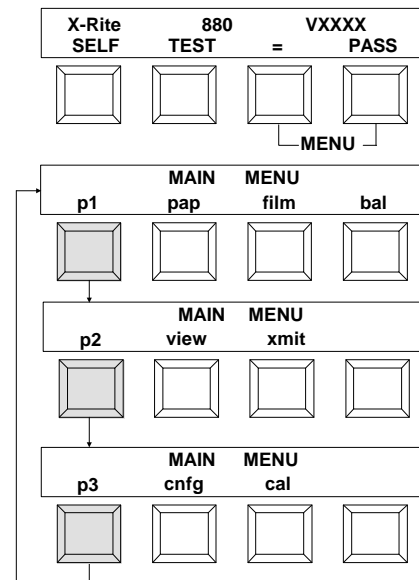

> **IMPORTANT!** To extend the life of the internal memory battery, it is recommended to leave the unit plugged into the wall socket.

5.

Keyboard Functions

The 880 has seven basic functions:

- pap (Paper) - sets the unit to the paper measuring function (ex., EP2, RA-4, CP-21, AP-92, R-3, P-3, etc.). The paper format selected will remain selected until changed. See Strip Format Flow Chart below.
- film - sets the unit to the film measuring function (ex., C-41, KBM, AP-70, etc.). The film format selected will remain selected until changed. See Strip Format Flow Chart below.
- bal - (Balance) - sets the unit into the printer balance measuring function (ex., Black Ringed Bull's-Eye, White Ringed Bull's-Eye, Cropped Bull's-Eye etc.). The printer balance format selected will remain selected until changed. See Strip Format Flow Chart below.
- view - used to view the data of the last strip measured. See Section 9.
- xmit (Transmit) - used to manually transmit the data of the last strip measured via the RS232 port. See Sec. 10.
- cal (Calibrate) - used for calibration.
- cnfg (Configuration) - allows presetting of certain functions.

Most of the functions have a built-in "HELP" message. To activate the help message simply hold the key depressed until the message is displayed, and then release. The message can be temporarily paused by pressing the key back down while the message is scrolling.



HELP: PAPER
"pap" key select

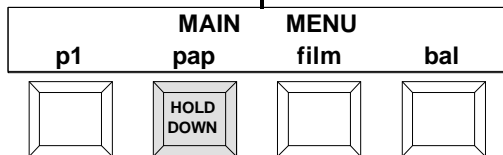

Strip Format Flow Chart

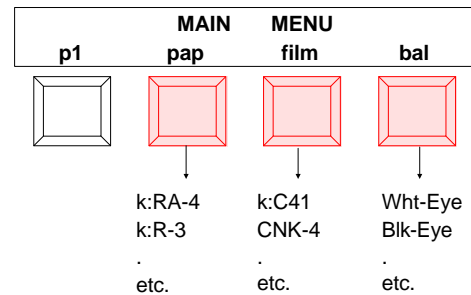

Refer to Control Strip and Balance Print Format Guide for a complete listing of available control strips.

6.

Configuring Your 880

Your 880 should initially be configured (tone, I/O, etc.) before proceeding to control strip measurements.

Shown is the procedure for modifying the unit configuration parameters. Refer to Appendix A3 for a more detailed explanation of available options.



> When a certain function is On or Off, the function will display in uppercase letters for On and lowercase letters for Off.

Step 1 - Refer to Appendix A3 to decide upon desired CNFG setting.

Step 2 - At Main Menu level, continually press [p#] until "p3" is displayed. Then press [cnfg].

Step 3 - Set lang (language option not available at this time).

Step 4 - Set tone control. Each depression of [TONE] will page through "OFF", "SOFT", and "LOUD."

Step 5 - Set Default. Each depression of [def] will alternate between "DEF" (On) and "def" (Off).

Step 6 - Press [P1] to advance to Page 2 configuration setup.

Step 7 - Press [IO preset] once (either center key) to initiate setup. Each depression, thereafter, of [IO preset] will page through "CUSTOM", "REPORT", "SPRD-SHT", "k:TNetA", "k:TNetXT", etc.

Step 8 - Press [load] to load in I/O preset and advance to "P2a" menu, or press [P2] to not load in preset and advance to "P2a" menu.

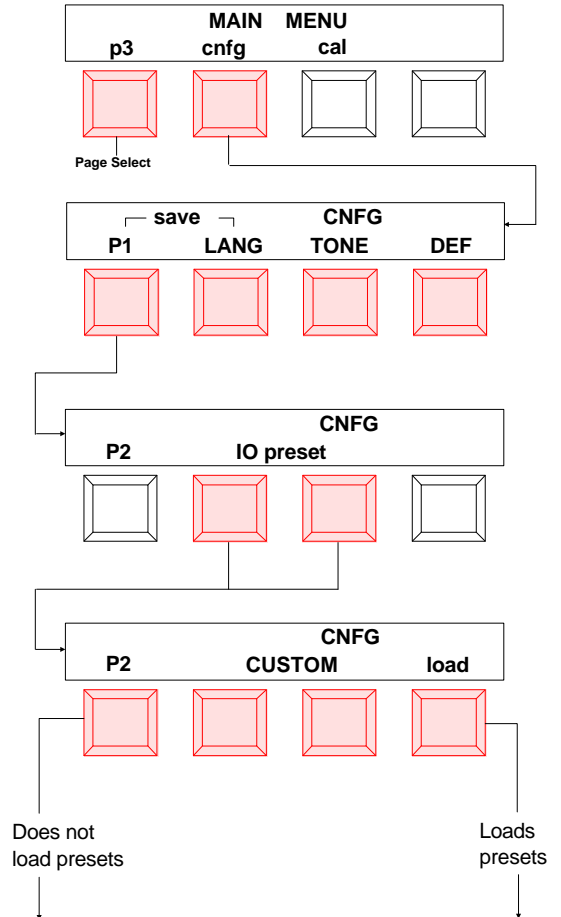

SECTION 6



Configuring Your 880 - continued.

Step 9 - *Set rci*. Each depression of **[rci]** will alternate between "**RCI**" (On) and "**rci**" (Off).

Step 10 - *Set pin5*. Each depression of **[pin5]** will page through "**OFF**", "**CTS**", and "**BUSY**."

Step 11 - *Set xon*. Each depression of **[xon]** will alternate between "**XON**" (On) and "**xon**" (Off).

Step 12 - Press **[P2a]** to advance to Page 2b configuration setup.

Step 13 - *Set dpt*. Each depression of **[dpt]** will alternate between "**DPT**" (On) and "**dpt**" (Off).

Step 14 - *Set comp*. Each depression of **[comp]** will alternate between "**COMP**" (On) and "**comp**" (Off).

Step 15 - *Set alf*. Each depression of **[alf]** will alternate between "**ALF**" (On) and "**alf**" (Off).

Step 16 - Press **[P2b]** to advance to Page 2c configuration setup.

Step 17 - *Set del*. Each depression of **[del]** will alternate between "**DEL**" (On) and "**del**" (Off).

Step 18 - *Set axmt*. Each depression of **[axmt]** will alternate between "**AXMT**" (On) and "**axmt**" (Off).

Step 19 - Press **[P2c]** to advance to Page 2d configuration setup.

Step 20 - *Set baud*. Each depression of **[baud]** will page through "**110**", "**300**", "**600**", "**1200**", "**2400**", "**4800**", "**9600**."

Step 21 - Press **[P2d]** and **[baud]** together to save the configuration changes.

"**Configuration Setting Saved**" is displayed, then display returns to Main Menu.

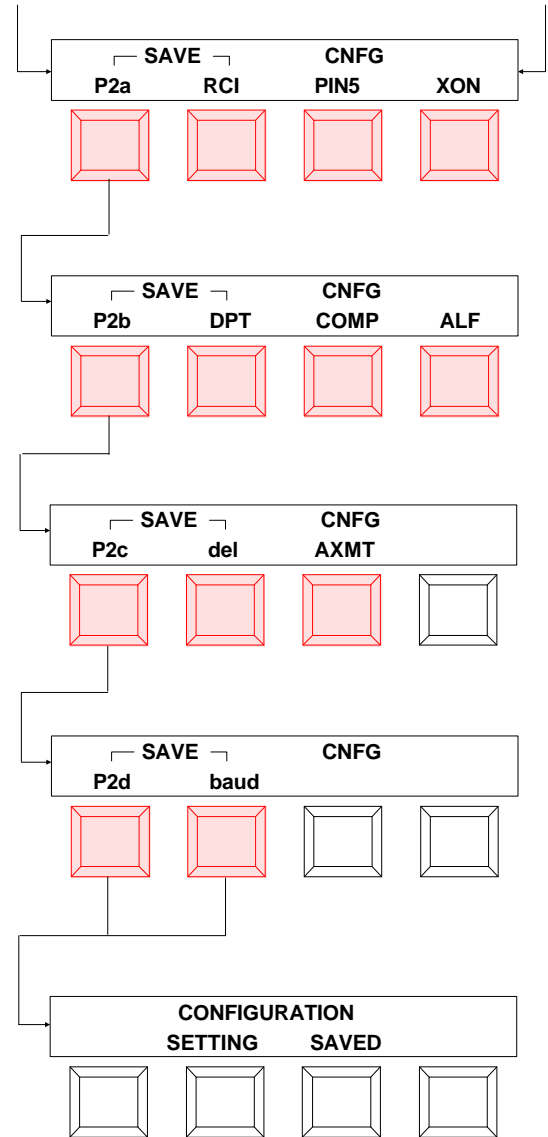

SECTION 6



When the keys labeled "**MENU**" are pressed together at anytime, the configuration procedure will be exited and the configuration changes made (if any) will NOT be saved.

7.

Adjusting Paper Guides

To accommodate different size strips, the 880 has an adjustable paper guide on each side of the strip entrance. Each paper guide has a pointer (triangle) that must be in line with the mark that you are going to set to.

The paper guide has settings marked 9 thru 30 to the left and right of the center diamond. Each mark is a 1/10 inch increment. 10 is equal to one inch and 20 equal to two inches.

The 880 will automatically display the left and right setting you should set the paper guides to.

EXAMPLE:

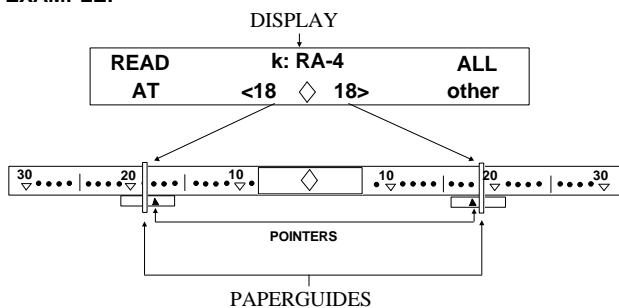

To move the paper guides to the desired location, lift-up on bottom slightly and slide left or right (see below).

INCORRECT

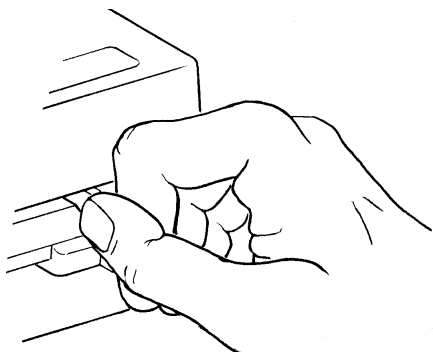

INCORRECT

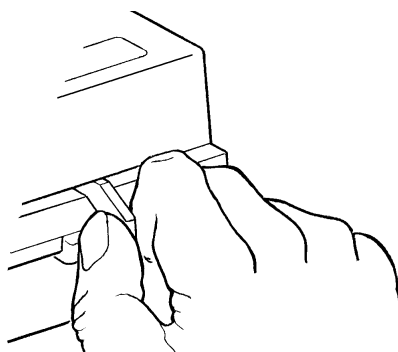

CORRECT

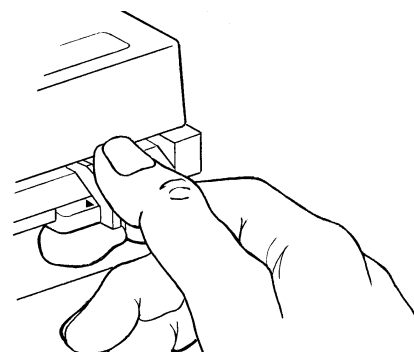

To accommodate 35mm wide strips, the 880 has a special stationary guide located above the diamond.

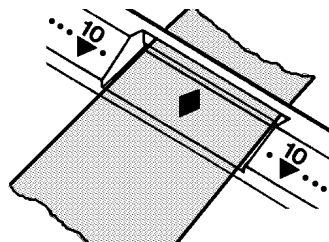
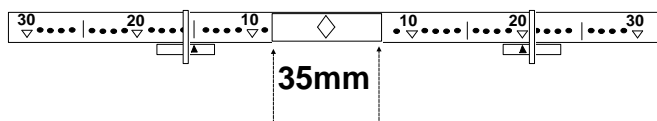

> Due to the amount of variation in printer balance strips, there are no paper guide setting displayed for any printer balance format.

8.

Taking Measurements

The following examples show you how to measure strips. The first example is a general procedure showing the basic steps for measuring any type of strip. The remaining examples show how to measure specific strips: Example 2 (3 pass paper - CP21); Example 3 (film - C41); and Example 4 (printer balance - U.N.O. 1-pass, black ring bull's-eye).



> **IMPORTANT!** When inserting strips (Paper, Film, or Printer Balance) into unit, there should be at least a 1.2 inch (30.5mm) leader before the outside edge of the first target. If not, the first target may not be detected. For leaderless strip measurements (less than 30.5mm), see Control Strip & Balance Print Format Guide, Sec. 4.

EXAMPLE 1:

Step 1 - Select the strip category by pressing **[pap]**, **[film]**, or **[bal]**.

For proper insertion direction of your particular strip, see Control Strip & Balance Print Format Guide, Sec. 1.

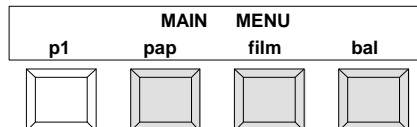

Step 2 - If the strip **format** is not correct, press **[other]** until the desired **format** is displayed.

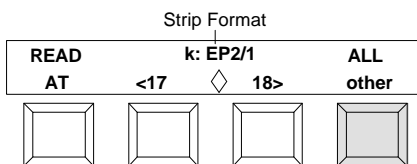

Step 3 - Adjust the paper guides according to the numbers displayed.



> There are no paper guide settings displayed for the printer balance strips.

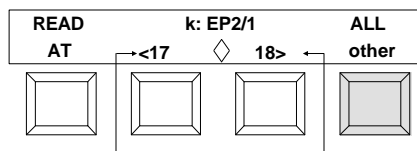

Step 4 - Insert the strip until it rests against the drive rollers. If measuring a multi-pass strip, note which color is to be measured (as displayed in upper right corner) and which paper guide to align strip with for each pass. For any pass the flashing guide no# indicates which guide(s) to use.

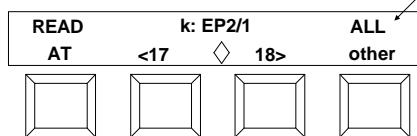

Step 5 - After the strip is measured "**PASS #1 OF 1 OK!**" will be displayed if the strip measured correctly.

- If the strip has more than one column to measure, the 880 will indicate the number of passes required.

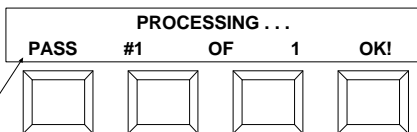

Taking Measurements - continued

Step 6 - "**TRANSMITTING DATA**" will display momentarily (if auto transmit is turned On in configuration) and then the measured data.

- Press [**stain**] the field select key, to page through fields.
- Note, if auto transmit is turned Off in configuration, pressing [**exit**] will allow the option of transmitting or not transmitting data.

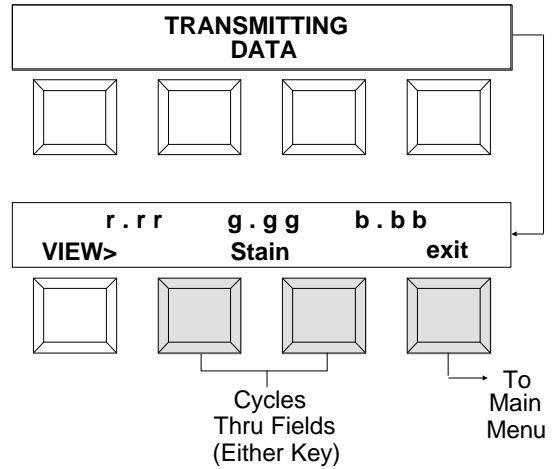

- > If "**INVALID READING**", "**UNRECOGNIZABLE STRIP**", or "**BUFFER OVERFLOW**" is displayed after strip is measured, try re-reading strip. If the same error message occurs after re-reading strip, refer to the Appendix, Sec. A1.
- > If the strip gets jammed in the unit, press the two keys labeled "**MENU.**" If this does not feed strip out, pull strip out slowly from the front of unit.
- > The 880 will not measure creased strips.

8.1. Measuring a Color Paper Strip

EXAMPLE 2 (CP21 Strip)

Step 1 - Press **[pap]**.

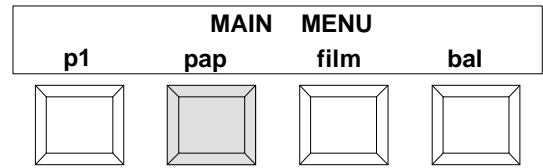

Step 2 - If "f:CP21" is not displayed, press **[other]** until it is.

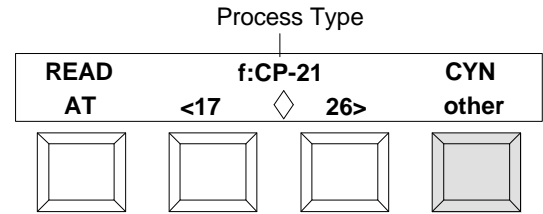

Step 3 - Set the paper guides as displayed. Left to 17 and right to 26.

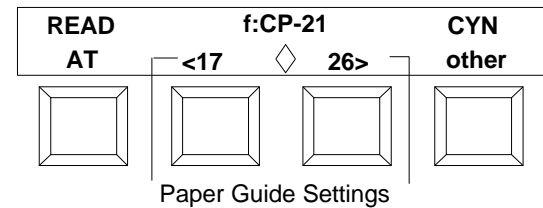

Step 4 - Align the strip with right guide (indicated by flashing right guide no.#) so you can measure the Cyan and Stain fields.

Insert strip until it rests against the drive rollers.

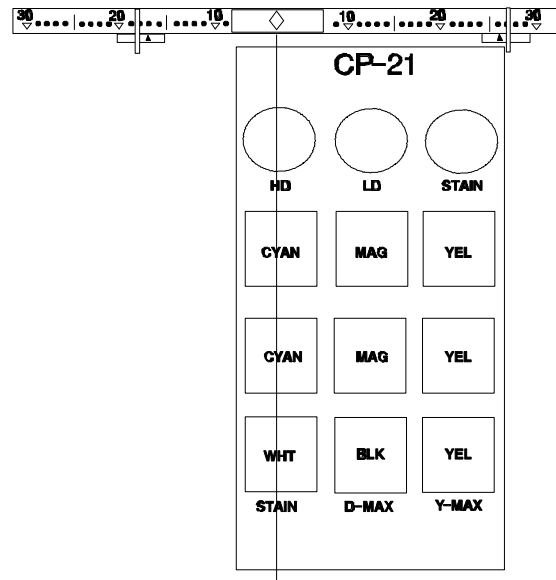

Measuring a Color Paper Strip - cont.

Step 5 - When prompted by display, align the strip with left guide (indicated by flashing left guide no.#) so you can measure the Magenta and Black fields.

Insert strip until it rests against the drive rollers.

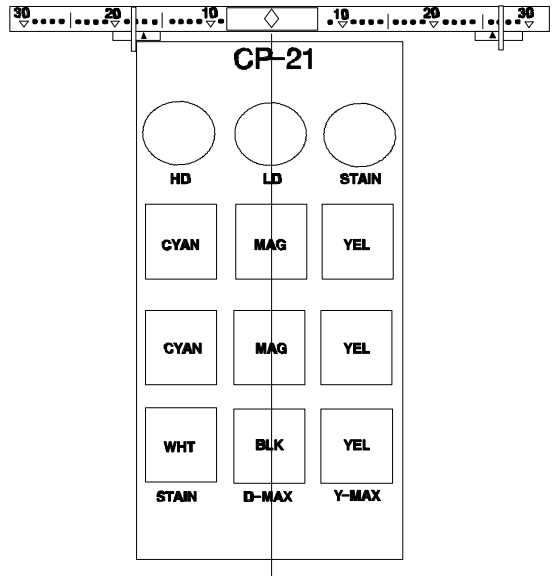

Step 6 - After 2nd pass complete, rotate strip and align it with the right guide so you can measure the Yellow field.

Insert strip until it rest against the drive rollers.

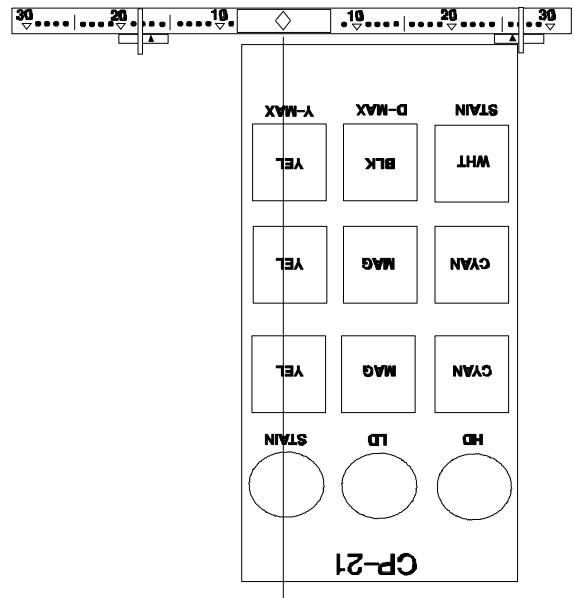

Step 7 - "TRANSMITTING DATA" will display momentarily (if auto transmit is turned On in configuration) and then the measured data.

- Press **[stain]** the field select key, to page through fields.
- Note, if auto transmit is turned Off in configuration, pressing **[exit]** will allow the option of transmitting or not transmitting data.



> If "INVALID READING", "UNRECOGNIZABLE STRIP", or "BUFFER OVERFLOW" is displayed after strip is measured, try re-reading strip. If the same error message occurs after re-reading strip, refer to the Appendix, Sec. A1.

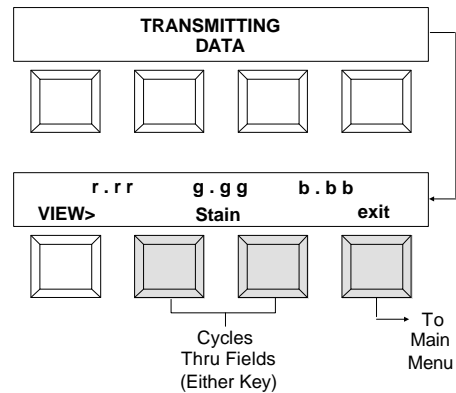

8.2. Measuring a Film Strip

EXAMPLE 3 (C41 Strip)

Step 1 - Press **[film]**.

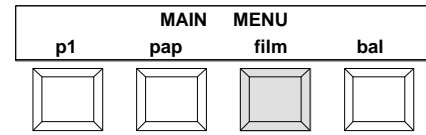

Step 2 - If "**k:C41**" is not displayed, press **[other]** until it is.

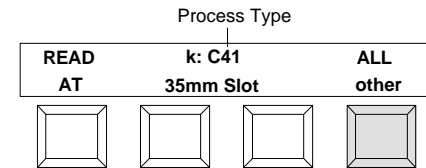

Step 3 - Insert the C41 strip into the 35mm slot until it rests against the drive rollers.



> A 16mm wide C41 control strip can not be measured, due to drive mechanism.

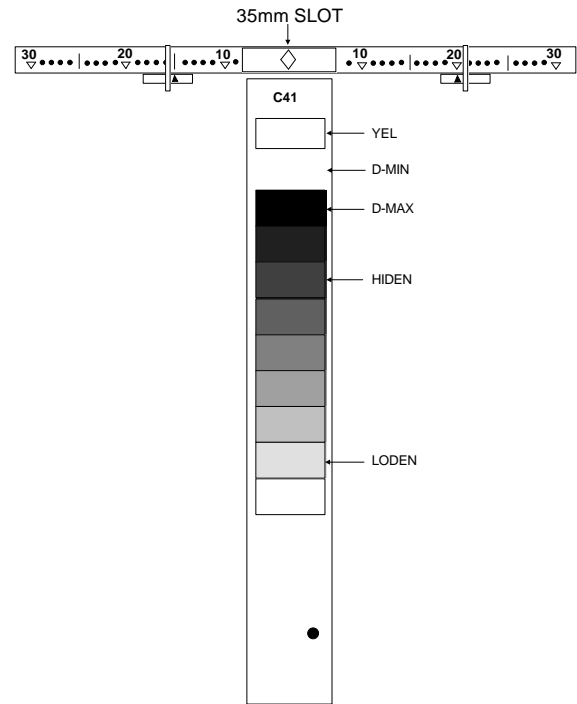

Step 4 - "**TRANSMITTING DATA**" will display momentarily (if auto transmit is turned On in configuration) and then the measured data.

- Press **[D-min]** the field select key, to page through fields.
- Note, if auto transmit is turned Off in configuration, pressing **[exit]** will allow the option of transmitting or not transmitting data.



> If "**INVALID READING**", "**UNRECOGNIZABLE STRIP**", or "**BUFFER OVERFLOW**" is displayed after strip is measured, try re-reading strip. If the same error message occurs after re-reading strip, refer to the Appendix, Sec. A1.

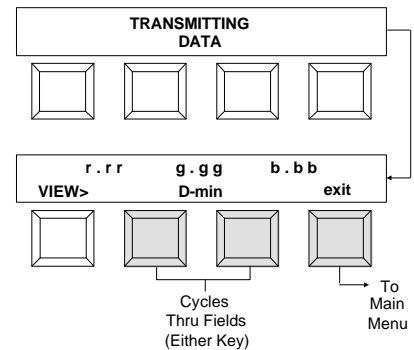

8.3 Measuring a Printer Balance Strip

EXAMPLE 4 (Black Ringed Bull's-Eye)

For additional details on Printer Balance see Control Strip & Balance Print Format Guide, Sec. 2.

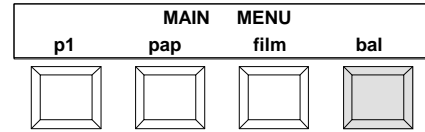

Step 1 - Press **[bal]**.

Step 2 - If "**Blk-Eye**" (Black-Ringed Bull's-eye) is not displayed, press **[other]** until it is.

Step 3 - Select print number. Each depression of the **[print no.]** key will page through "**Single**", "**UNO 3-Pass**", "**UNO 1-Pass**", "**NUO 1-Pass**", "**5-Print**", and "**Multi- ↑ ## ↓**".** Select "**UNO 1-Pass**".

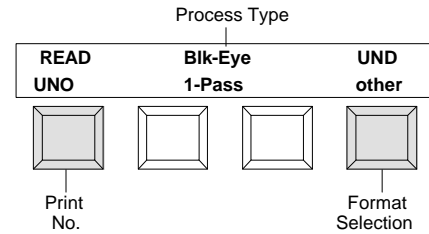

> Bull's-eyes must be complete circles (not overlapped) to be measured properly.

* Will display N.U.O. (Normal-Under-Over) if configured for Copal® printers.

** When "**Multi- ↑ ## ↓**" is selected, a print measurement quantity of "0" to "35" can be entered by pressing the [↑] to increase or the [↓] key to decrease print number.

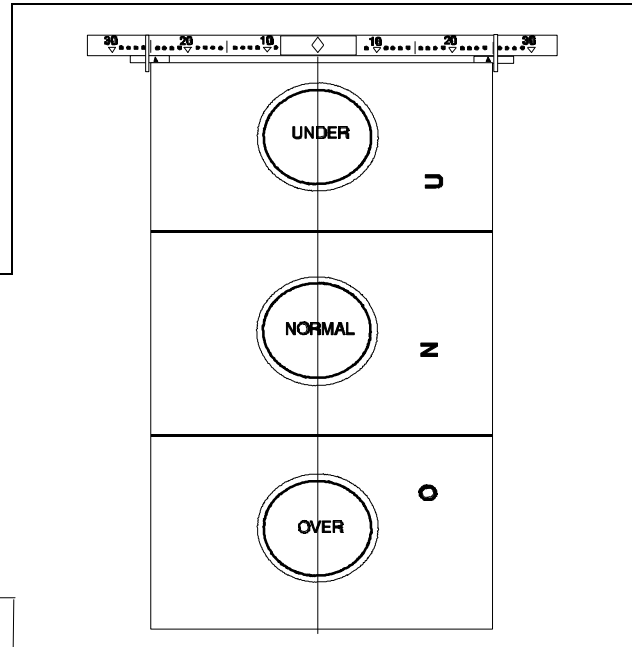

> Under end of strip must be inserted first to receive values in U.N.O. sequence.

Step 4 - With "Under" end of strip facing unit, position strip with center of bull's-eye over middle diamond. Slide paper guides next to strip. Insert strip until it rests against the drive rollers.

Step 5 - "**TRANSMITTING DATA**" will display momentarily (if auto transmit is turned On in configuration) and then the measured data.

- Press **[norm]** the field select key, to page through fields.
- Note, if auto transmit is turned Off in configuration, pressing **[exit]** will allow the option of transmitting or not transmitting data.

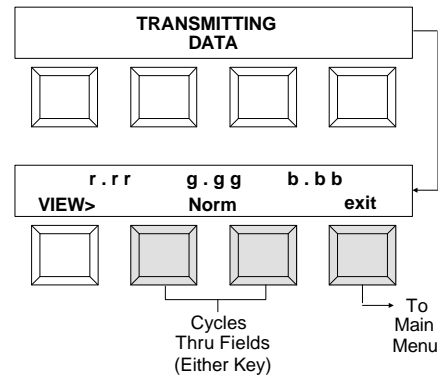

> If "**INVALID READING**", "**UNRECOGNIZABLE STRIP**", or "**BUFFER OVERFLOW**" is displayed after strip is measured, try re-reading strip. If the same error message occurs after re-reading strip, refer to Appendix A1.

9.

Viewing Data

The view function allows you to view data of the last measurement taken in the paper, film, and printer balance categories.

Step 1 - Select View function.

- Press **[p1]**.
- Press **[view]**.

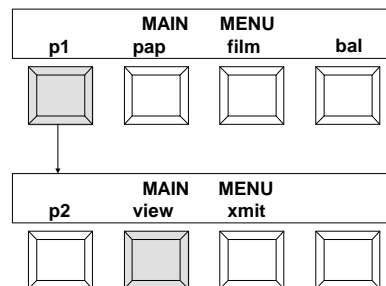

Step 2 - Select the strip category.

- Press **[pap]**, **[film]**, or **[bal]**.

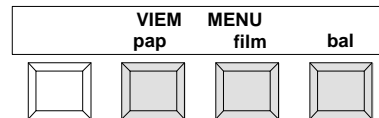

Step 3 - The data is displayed.

- Press either of the two middle keys to cycle thru the fields.
- Press **[exit]** to return to View Menu.
- Press the two keys labeled "MENU" to exit out of view and return to "MAIN MENU."

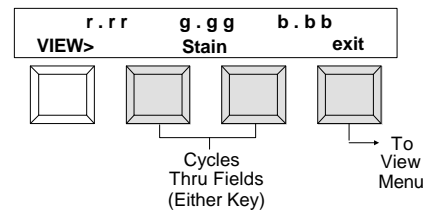

10.

Transmitting Data

The transmit function allows you to transmit data (all or individual fields) of the last measurement taken in the paper, film, and printer balance categories.

Step 1 - Select Transmit function.

- Press [p1].
- Press [xmit].

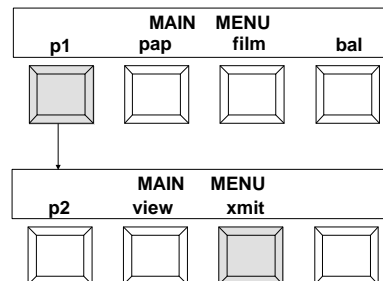

Step 2 - Select the strip category.

- Press [pap], [film], or [bal].

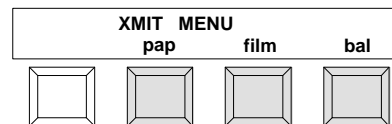

Step 3 - The data is displayed.

- Press either of the two middle keys to select the field to transmit. Note, "ALL" will display after the last field. This will allow you to transmit all field data of the strip at once.
- Press [xmit] to transmit data.
- Press [exit] to return to Xmit Menu.
- Press the two keys labeled "MENU" to exit out of transmit and return to "MAIN MENU."

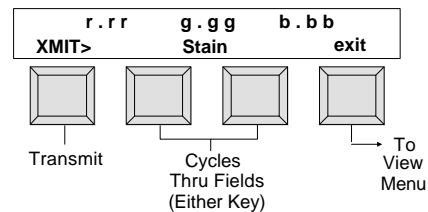

> The instrument can be setup to automatically transmit data after each complete set of readings (see Section 6.)

11.

Calibration

The 880 has a unique feature called *Auto-Cal*, which has a patent pending by X-Rite. When the instrument automatically calibrates, the density values are set precisely to that of the paper measured for reflection, and to no film (air) for transmission. Using a sophisticated algorithm, the slope of the instrument is calculated so that the numbers are exactly equal to the logarithmic value of the light attenuated. This allows the 880 to automatically adjust it's own slope.

The 880 has many self checking algorithms built in to verify the accuracy of calibration. If you wish to maintain accuracy verification, we suggest that you obtain a C41 reference strip and a paper reference strip. Measure each strip and record the density values. Place the strips in an envelope and store them in a dry, cool environment. Periodically, measure them to verify accuracy. Note, the reference strips tend to drift in density with time, consult the manufacturer's specifications for expected density changes.

 > The Auto-Cal strip can be cleaned with a mild soap detergent. **DO NOT** clean below the bottom triangle. The attached label is not coated and will smear when moisture is applied. **DO NOT** get fingerprints on any portion of the strip, handle by the edge.

If your Auto-Cal strip gets ruined or worn, you can order a replacement from X-Rite or your local dealer. Order Part Number 880-100.

 > There are two types of calibration procedures, auto and manual. **AUTO is the standard method of calibration.** If you want your 880 to measure the same as another densitometer that has the same response, you can use the manual procedure (See Section 11.2).

The active calibration procedure is determined by uppercase letters. **AUTO/manual** = AUTO is active, **auto/MANUAL** = MANUAL is active.

Auto and manual will toggle between upper and lower case letters by pressing the key below the respective function.

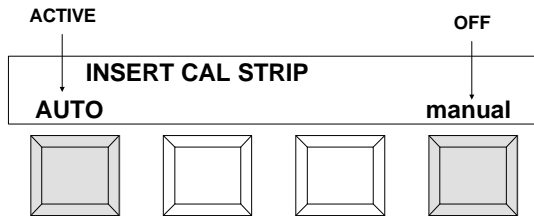

X-Rite Auto-Cal Strip

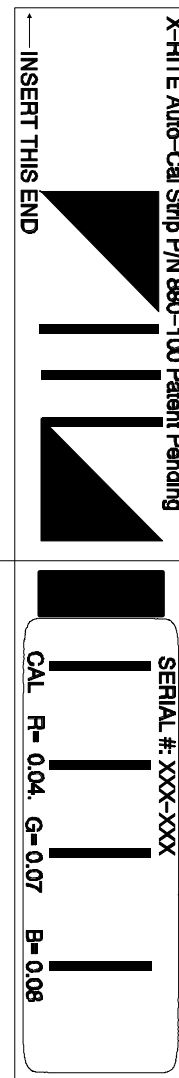

DO NOT CLEAN BELOW THIS LINE!

11.1. Auto Calibration Procedure

Step 1 - At Main Menu level, repeatedly press the [p#] until "p3" is displayed. Press [cal] to activate calibration.

"CALIBRATING TRANSMISSION" is displayed as the unit automatically calibrates transmission (reads air).

"INSERT CAL STRIP" is displayed.

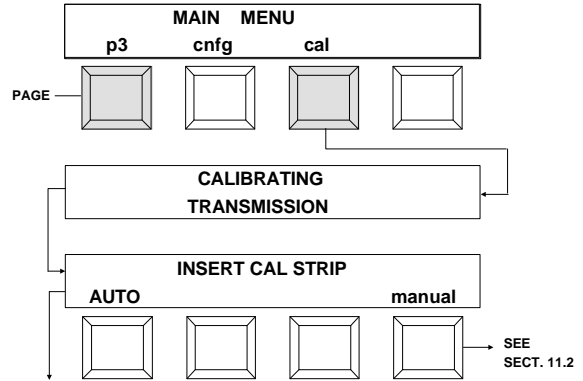

Step 2 - Insert the Auto-Cal strip into the 35mm slot until it rests against the drive rollers. The strip indicates which end to insert.



> If "UNRECOGNIZABLE STRIP" is displayed after strip is outputted, smudgemarks may be causing error message. Try cleaning strip (see sec. 11). If cleaning will not resolve problem, enter calibration manually then measure strip (see sec. 11.2).

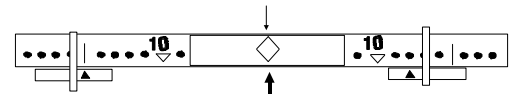

NOTE



Auto Calibration procedure - cont.

Step 3 - "**READING**" is momentarily displayed. Calibration is finished and the calibration density values are displayed momentarily.



> The 880 will automatically return to the Main Menu.

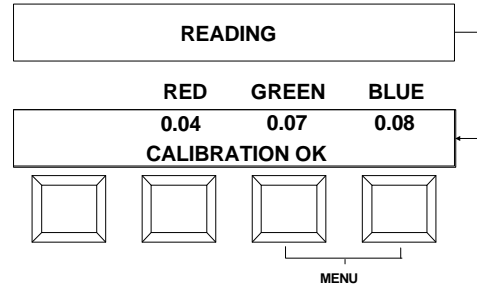

11.2. Manual Calibration or Correlating to Another Reflection Densitometer

The manual calibration procedure can be used to correlate the low densities of the 880 to another densitometer. Doing this will allow the 880 to measure approximately the same as another densitometer that has the Status A reflection response, and has been calibrated to ANSI Standards.

Step 1 - Calibrate the densitometer that you want the 880 to correlate to, using the instrument's own reference.

Step 2 - Using the same densitometer, measure the white area below the first black bar on the X-Rite Auto-Cal strip and record the Red, Green, and Blue values.

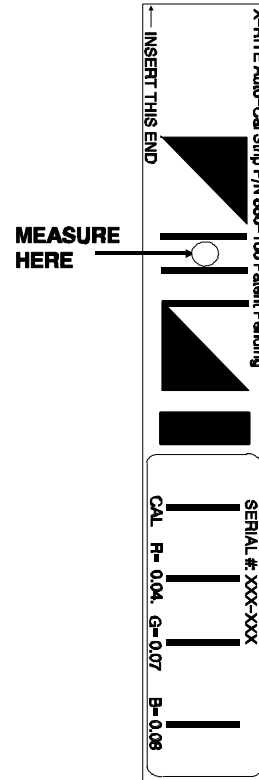

Step 3 - At Main Menu level, repeatedly press [p#] until "p3" is displayed. Press [cal] to activate calibration.

"**CALIBRATING TRANSMISSION**" is displayed as the unit automatically calibrates transmission (reads air).

"**INSERT CAL STRIP**" is displayed. **DO NOT INSERT AUTO CAL STRIP!**

Step 4 - Press [manual].

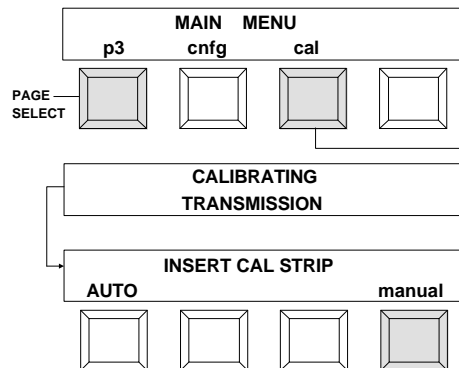

Manual Calibration - continued

The current settings are displayed.

Step 5 - Enter the Red, Green, and Blue values you recorded (In Step 2) into the 880.

- Press [→] to advance the cursor to the next color.
- Press [↑] to increase the value.
- Press [↓] to decrease the value.
- After all values have been entered press [→] one more time to advance to next step.

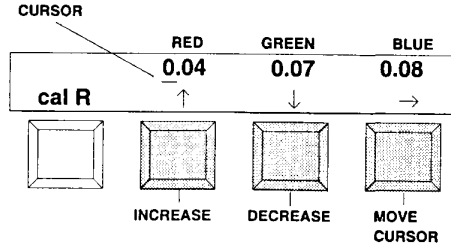

"INSERT CAL STRIP" is displayed.

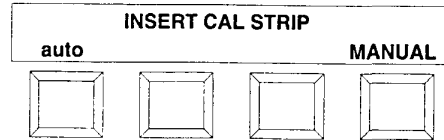

Step 6 - Insert the Auto-Cal strip into the 35mm slot until it rests against the drive rollers. The strip indicates which end to insert.

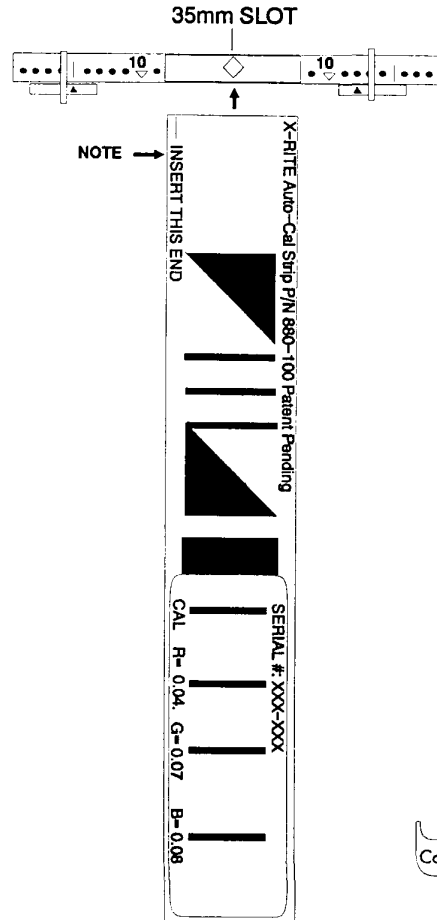

Manual Calibration - continued

Step 7 - "**READING**" is momentarily displayed. Calibration is finished and the calibration density values are momentarily displayed. The 880 will automatically return to the Main Menu.

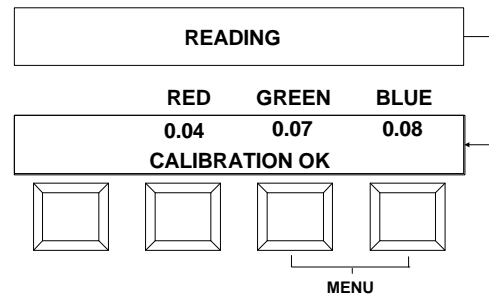

11.3. Frequency of Calibration

Under normal operating conditions, the instrument should be calibrated once a week.

12.

General Maintenance

Important! Before proceeding with the following troubleshooting chart:

- Make sure strip being measured has been properly inserted and is free of smudges, scratches, and blemishes.
- Make sure the unit has been properly calibrated.
- Make sure that strips and the unit are free of dust and lint (see Sec. 12.2).
- If a wrong reading problem exists, recalibrate unit and recheck problem.

12.1. Troubleshooting Chart

PROBLEM	CAUSE	SOLUTION
Reflection measurement incorrect.	Unit needs calibration.	Recalibrate unit.
	Reflection cal strip dirty or bad.	Clean reflection cal strip or replace if bad.
	Read lamp weak.	Replace read lamp.*
Transmission measurement incorrect.	Unit needs calibration.	Recalibrate unit.
	Read lamp weak.	Replace read lamp.*
Transmission and Reflection measurements incorrect.	Unit needs calibration.	Recalibrate unit.
	Read lamp weak.	Replace read lamp.*
Measurements drift.	Unit needs calibration.	Recalibrate unit.
	Read lamp weak.	Replace read lamp.*
Unit will not calibrate.	Dirty (fingerprints) or bad cal strip.	Clean or replace cal strip.
Read lamp not working.	Read lamp open.	Replace read lamp.*
Measurements unrepeatable/incorrect.	Film/paper misaligned.	Reinsert strip.
	Film/paper has blemishes or scratch.	Use different strip.
	Reflection optics loose.	Plug reflection optics in place.
"INVALID READING", "UNRECOGNIZABLE STRIP", or "BUFFER OVERFLOW" message displays after measurement.	See Appendix, Sec A1.	See Appendix, Sec. A1.

* The instrument has a failure monitor that in most cases will automatically indicate when the lamp needs replacement.

12.2. Optics Cleaning

To remove any dust and lint from the optics and drive wheel assembly, follow the procedure shown approximately once a week.

Step 1 - Insert tube from the canned air into slip insertion slot (on front of unit). Make sure the air is clean and free of moisture.

Step 2 - With back and forth motion spray air into insertion slot from one end to the other. Do this several times. This should remove any accumulated dust and lint.

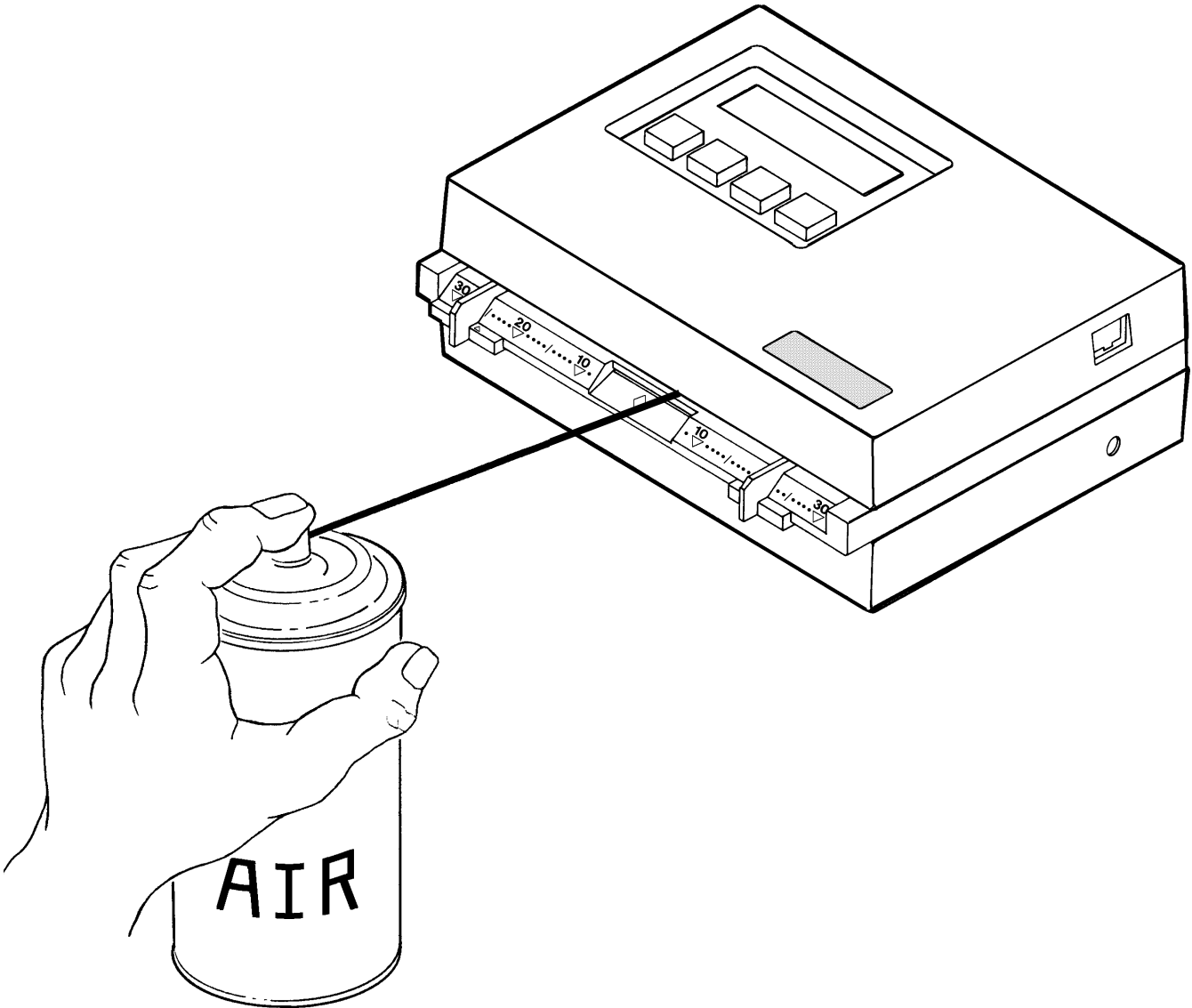

12.3. Read Lamp Replacement (P/N 880-07)

Step 1 - Remove four screws [2] securing the bottom cover [3] with a phillips-head screwdriver. Leave bottom cover [3] on unit.

Step 2 - Holding top [1] and bottom [3] covers in place, turn unit over so it rests on the bottom cover [3]. Remove top cover [1].

Step 3 - Locate optics assembly [4] and remove screw and washer [5] in the middle of lamp assembly P.C.B. [6].

Step 4 - Lift out old lamp assembly [6] and discard.

Step 5 - Install new lamp assembly [6] by carefully inserting lamp [6] into housing [7] and lamp pins [8] into lamp connector. Press down gently to make sure connector pins [8] are properly seated.

Step 6 - Secure lamp screw and washer [5] in place.

Step 7 - Carefully clean any dust or plastic chips off circuit board and top cover [1] using moisture free compressed air. Place top cover back on instrument.

Step 8 - Holding the top and bottom covers in place, turn unit over so that it rests on the top cover [1].

Step 9 - Remove bottom cover [3]. Clean circuit board and bottom cover [3] with compressed air then place bottom cover [3] back on instrument.

Step 10 - Secure bottom cover [3] to instrument with four screws [2] using a phillips-head screwdriver.

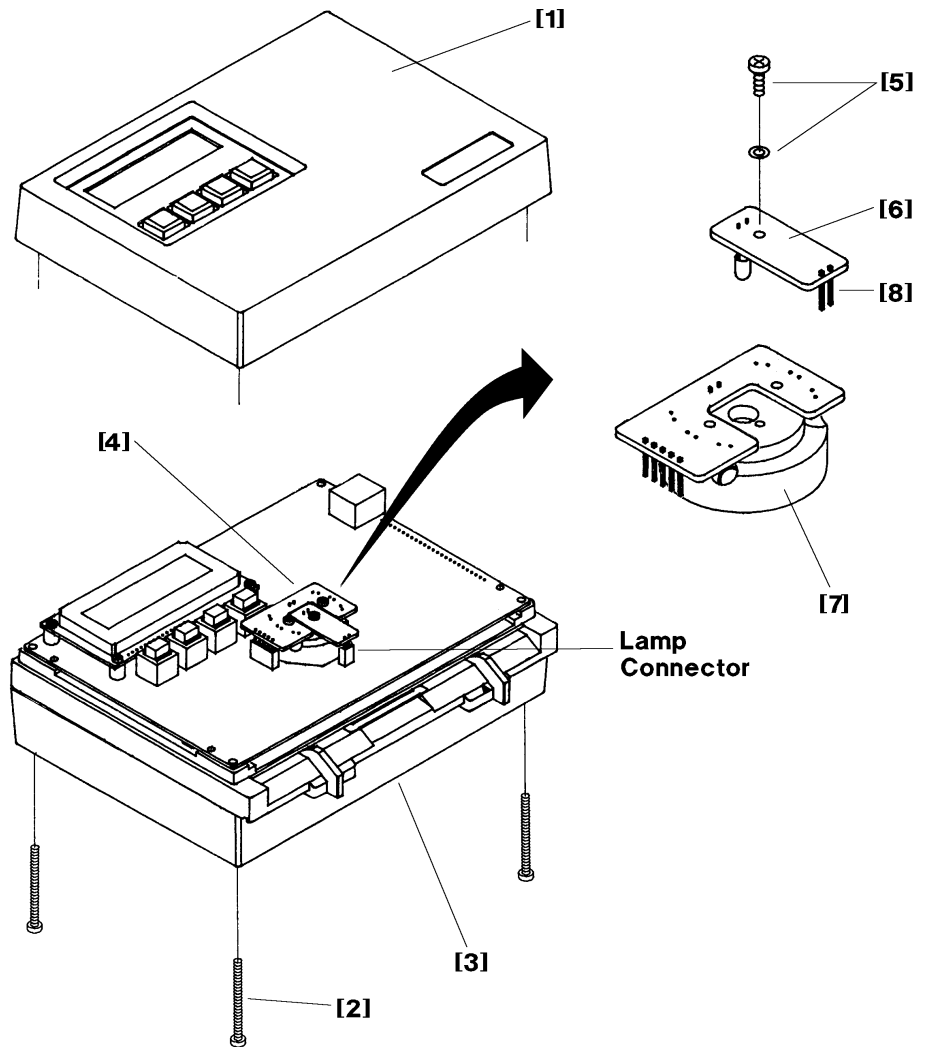

A.

Appendix

A.1. Error Messages

MESSAGE	REASON	POSSIBLE CAUSE	SOLUTION
INVALID READING PLEASE RE-READ! or UNRECONIZABLE STRIP! or BUFFER OVERFLOW (During measurement)	Unit did not recognize strip.	Wrong strip selection.	Select correct format.
		Strip did not have a 1.2" leader before first target.	Use strip with leader or refer to the Control Strip & Balance Print Format Guide, Sec. 4 for leaderless strip insertion.
		Strip not inserted in the correct direction.	Refer to Control Strip & Balance Print Format Guide, Sec. 1 for strip insertion direction.
		Unit needs calibration.	Calibrate unit, see Sec. 11.
		Measurement region not aligned with center diamond, or strip not tracking properly.	Make sure measurement patches are centered with diamond and center line. Usually setting the paper guides to the numbers indicated on the display will take care of tracking problem. Make sure strip feeds straight through unit and does not curve toward one side.
		One or more measurement patches are cloudy, have excessive gradients, or have flecks.	Process and then measure a new strip.
		NOTE: If first read causes invalid error message try re-reading strip again. Measurement tolerances across the patch are opened slightly on second read.	
		Motor drive roller slippage due to restraint or obstruction, or contamination of rollers from reading wet strips.	Remove restraint/obstruction or dry drive rollers with air.
Lamp failure (weak or bad).	Perform transmission calibration to test lamp, see Sec. 11.		



Error Messages - continued

MESSAGE	REASON	POSSIBLE CAUSE	SOLUTION
UNRECOGNIZABLE AUTO CAL STRIP! (During reflection calibration)	Unit did not recognize cal strip inserted.	Strip inserted in back- wards or upsidedown.	Insert strip correctly, see Sec. 11.
		Cal strip is dirty.	Clean cal strip, see Sec. 11.
STRIP RESTRAINED RE-INSERT STRIP! (During reflection calibration)	Cal strip did not feed consistently.	Strip path is blocked by debris keeping cal strip from feeding properly.	Clean strip path, see Sec. 12.2
		Motor drive roller slip- page due to restraint or obstruction, or contami- nation of rollers from reading wet strips.	Remove restraint/obstruction or dry drive rollers with air. If problem persists, return unit for service.
WARNING MOTOR ERROR! (During reflection calibration)	Unit senses motor abnormality.	Strip was pulled out from back during calibration.	Do Not pull on strip during measurement.
		Motor brush wear. NOTE: If motor error message constantly displays, unit should be returned for proper service.	Return unit for service.
PRESET MEMORY PLEASE CALIBRATE (During power-up)	Memory data detected in unit is not valid.		Recalibrate unit, see Sec. 11.
WARNING LAMP MARGINAL! (During transmission calibration)	Lamp output is less than 50% of its peak intensity (but still able to read).	Lamp has aged close to end of its useful life.	Order new lamp - replace at convenient time.
WARNING REPLACE LAMP! (During transmission calibration)	Lamp output is less than required intensity. Measurement accuracy of unit is questionable at this point.	Useful lamp life has expired.	Replace lamp immediately, see Sec. 12.3.

A.2. Term Abbreviations

ALF	Automatic Line Feed
ALL	Strip is one pass and may be read in either direction (strip measurement mode)
AXMT	Automatic Transmit
bal	Printer Balance
baud	Varies unit of data transmission speed.
BLK	Black patch must be read first (strip measurement mode)
cal	Calibration
c:I/O #1	Copal, I/O #2
c:I/O#2.	Copal, I/O #1
cnfg	Configuration
COMP	Compact
CTS	Clear to Send
CYN.	Cyan patch must be read first (strip measurement mode)
del	Delete
DEL	Delay (in configuration)
DPT	Decimal Point
f:TECOM	Fuji, Tecom System
HD	High Density patch must be read first (strip measurement mode)
k:C.A.P.	Kodak, Create a Print
k:SYS ² 5→ ⁷ 5.	Kodak, Systems 25 thru 75
k:TNetA	Kodak, Technet A
k:TNetXT	Kodak, Technet XT
LANG.	Language
MIN	Minimum Density patch must be read first (strip measurement mode)
NRM	Normal patch must be read first (strip measurement mode)
NUO 1-Pass	Normal/Under/Over in one pass
pap	Paper
PIN5	Pin5 of RS232 port can be set to Off, Busy, or CTS
p1 thru p3	Page #1 thru Page #3
p2a thru p2d	Page #2a thru Page #2d
RCI	Remote Control Interface
SPRD-SHT	Spread Sheet
UND.	Under patch must be read first (strip measurement mode)
UNO 1-Pass	Under/Normal/Over in 1 pass
UNO 3-Pass	Under/Normal/Over in 3 passes
xmit	Transmit
YEL	Yellow patch must be read first (strip measurement mode)

A.3. Unit Configuration Definition

The configuration setup contains two pages: Page 1 (**LANG, TONE, & DEF**) and Page 2 (**I/O Presets**). The factory preset and configuration explanation is as follows:

PAGE 1

- LANG [ENG]
- TONE [LOUD]
- DEF [OFF]

PAGE 2

- IO PRESET [CUSTOM]

Page 2a

- RCI [OFF]
- PIN5 [OFF]
- XON [OFF]

Page 2b

- DPT [ON]
- COMP [ON]
- ALF [ON]

Page 2c

- DEL [OFF]
- AXMT [OFF]

Page 2d

- BAUD [1200]

PAGE 1

- **LANG (Languages)**
Language option not installed at this time.
- **TONE Off/Soft/Loud**
Allows the tone volume to be set to Off, Soft, or Loud.
- **DEF (Default) On/Off**
Default set to OFF will cause the unit to default to the last format read for each of the 3 format categories (PAP, FILM, & BAL). Default set to ON will lock in the formats selected at the point default was turned on.

PAGE 2

- **I/O Preset**
Determines the output that will be used, and will automatically select the proper configuration. Refer to the next page for a listing of available I/O Presets.
If I/O preset is set to "**CUSTOM**" all other parameters (i.e., baud, rci, etc.) will have to be set. If I/O preset is set to anything else (i.e., k:TNetA, k:TNetXT, etc.) all necessary parameters will automatically be set.

Page 2a

- **RCI (Remote Control Interface) On/Off**
Enables or disables the ability to externally control the unit via the serial I/O port.
- **PIN5 Off/CTS/Busy**
Determines the status of the handshaking input on Pin5 of the RS-232 I/O port. Pin5 may be interpreted as BUSY, CTS (clear to send), or set to OFF (i.e., ignored).
- **XON On/Off**
When set to On (XON), enables bidirectional transmit On/Off protocol. When set to Off (xon), the unit ignores XON/XOFF codes. Note: Usage limited to output at this point.

Unit Configuration Definition - continued

Page 2b

- DPT (Decimal Point) On/Off

Enables or disables the decimal point during print-out. When set to On (DPT), the decimal point will be included in the data. When set to Off (dpt), no decimal point will be output with the data.

- COMP (Compact) On/Off

Varies the output format of the I/O port. When set to On (COMP), a space will be transmitted after each of the three color's (R,G,B) data values and then the delimiter. When set to Off (comp) each color's data value is delimited with a CR (or CR LF if ALF is enabled).

- ALF (Automatic Line Feed) On/Off

Enables or disables a line feed along with each carriage return of the output data.

Page 2c

- DEL (Delay) On/Off

Enables or disables a one second delay between each set of Red, Green, Blue density data sent out of the I/O port.

- AXMT (Automatic Transmit) On/Off

Enables or disables automatic transmission of information after a reading was taken.

Page 2d

- BAUD (Rate) 110/300/600/1200/2400/4800/9600

Determines the output rate (characters per second) of the I/O port. Available outputs are: 110, 300, 600, 1200, 2400, 4800, & 9600.

When a certain I/O preset is selected (other than CUSTOM) the necessary parameters (e.g., rci, baud, etc.) will automatically be setup. Below is a chart listing the parameters that are set for each I/O preset; the parameters that can and cannot be changed for each I/O preset; and the parameters that remain unaffected.

I/O PRESET	RCI	PIN5	XON	DPT	COMP	ALF	DEL	AXMT	BAUD
CUSTOM	TTL(U)	Off (U)	Off (U)	On(U)	On(U)	On(U)	Off(U)	On(U)	1200(U)
REPORT	*	*	*	On(L)	On(L)	On(U)	Off(L)	Off(U)	*
SPRD-SHT	*	*	*	*	Off(L)	*	*	On(L)	*
k:TNetA	Off(L)	Off(L)	Off(L)	Off(L)	On(L)	On(L)	On(L)	On(L)	300(L)
k:TNetXT	Off(L)	CTS(L)	Off(L)	Off(L)	On(L)	On(L)	Off(L)	On(L)	*
k:C.A.P.	Off(L)	CTS(U)	Off(L)	Off(U)	On(U)	On(U)	Off(L)	On(L)	9600(L)
k:SYS25-75	Off(L)	CTS(L)	Off(L)	Off(L)	On(L)	On(L)	Off(L)	On(L)	*
f:TECOM	Off(L)	Off(L)	Off(U)	Off(U)	Off(U)	Off(U)	Off(U)	On(U)	1200(U)
c:I/O#1	*	Off(L)	Off(L)	Off(U)	On(U)	On(U)	On(U)	On(L)	9600(L)
c:I/O#2	*	Off(U)	Off(U)	Off(U)	On(U)	On(U)	On(U)	On(U)	9600(U)
MITSY#1	Off(U)	Off(U)	Off(U)	Off(L)	Off(L)	Off(L)	Off(U)	On(U)	300(L)
MITSY#2	Off(L)	Off(L)	On(U)	Off(L)	Off(L)	Off(L)	Off(L)	On(L)	300(U)
NORITSU	Off(L)	CTS(U)	Off(L)	Off(L)	On(L)	On(L)	Off(L)	On(L)	2400(U)
n:QSSnet	Off(U)	Off(U)	Off(U)	Off(U)	Off(U)	Off(U)	Off(U)	On(U)	2400(U)
kn:Net	TTL(U)	Off(U)	Off(U)	Off(U)	On(U)	Off(U)	Off(U)	Off(U)	2400(U)

U (unlocked) = Parameters that were automatically set during I/O preset selection, that **can be** changed.

L (locked) = Parameters that were automatically set during I/O preset selection, that **cannot** be changed.

* = Parameters that remain unchanged from previous settings, and **can be** changed.

k: = Kodak, **f:** = Fuji, **c:** = Copal, **kn:** = Konica, **n:** = Noritsu

A4. Densitometer Specifications

Transmission (negative) Process Control

Film Width	35mm fixed slot or 1.4 - 6.0 inch adjustable
Measurement Speed	1.3 inches/second
Spectral Response	Status M
Density Range	0 - 4.0D
Density Accuracy	+/- .02D (0-3.0D), +/- 1% (3.1D-3.4D), +/- 3% (3.5D-4.0D)
Density Repeatability	+/- .01D (0-3.0D)
Control Strip Measurement Area.....	0.375" (length) x 0.5" (wide) minimum

Reflection (paper) Process Control and Printer Balance

Paper Width	1.4 - 6.0 inches (adjustable slot)
Measurement Speed	1.3 inches/second
Control Strip Measurement Area.....	0.375" (length) x 0.5" (wide) minimum
Printer Balance Measuring Area075" diameter minimum
Spectral Response	Status A
Density Range	0 - 2.5D
Density Accuracy	+/- .02D
Density Repeatability	+/- .01D

General Specifications

A.C. Adaptor (115VAC - P/N SE30-61) (230VAC - P/N SE30-62)	12VDC @ 0.7amp
Dimensions	7.2" x 6.0" x 2.75" (182.8mm x 152.4mm x 69.8mm)

A5. Accessory Items

X-Rite does carry a variety of "DB" type adaptors and cables to interface your densitometer to a computer or printer. Ask your X-Rite representative or call X-Rite, Inc. to find out which adaptor or cable will best meet your requirements.

880 Series RS232C Interface Manual..... P/N 880-506



X-Rite, Incorporated – World Headquarters
3100 44th Street, S.W. • Grandville, Michigan 49418 • U.S.A
Tel: (616) 534-7663 • Customer Support Fax: 616-534-0723
Technical Services Fax: 616-534-7722 • <http://www.x-rite.com>

X-Rite GmbH
Charlottenstraße 61 • 51149 Köln • Deutschland
Tel: (49) 2203-91450 • Fax: (49) 2203-914519

X-Rite Asia Pacific Ltd.
Room 1004-05 • Kornhill Metro Tower • 1 Kornhill Road
Hong Kong • Tel: (852) 2-568-6283 • Fax: (852) 2-885-8610

X-Rite Ltd.
Lower Washford Mill • Mill Street • Buglawton
Congleton, Cheshire CW12 2AD • U.K.
Tel: (44) 1260-279988 • Fax: (44) 1260-270696