

INTRODUCTION. The following products are described in this manual:

Examolite TC-440B is an overhead luminaire that provides blended fluorescent daylight at 7500K. It is used for grading, sorting, and visual quality inspections.

Examolite SD-840B is an overhead luminaire that provides simulated fluorescent Daylight (D75, D65, or D50), Illuminant A (Incandescent), and cool white fluorescent (CWF). It is used for visual color evaluations, metamerism testing, and in applications where products need to be evaluated under multiple light sources.

Proflite PLD-440 is an overhead luminaire that provides simulated fluorescent daylight (D75, D65, or D50). It is a 4-lamp, single source fixture typically used in viewing booth installations for visual color evaluations.

Proflite PLD-840 is an overhead luminaire that provides simulated fluorescent daylight (D75, D65, or D50). It is an 8 lamp, single source fixture that provides higher levels of illumination for open room applications. A dual source fixture can also be achieved by combining four lamps of two different sources in one PLD-840 fixture. It is used for visual color evaluations.

SAFETY INSTRUCTIONS

PLEASE READ AND FOLLOW INSTRUCTIONS—Follow all instructions before attempting installation and operation.

KEEP INSTRUCTIONS—Retain these instructions for future reference. Once you have read these instructions, keep them available for other operators to read.

OBEY ALL WARNINGS—Please comply with all warnings and safeguards in these instructions. They have been written to keep you and your fixture safe.

CHOOSE PROPER POWER SOURCES—Use the proper power source. If you have any doubt, consult the label on the inside of the fixture for this information.

NOT EXPLOSION-PROOF—This fixture is *not* explosion-proof and should *not* be used in a hazardous atmosphere with exposure to flammable substances.

TURN OFF FIXTURE BEFORE CHANGING ANY LAMPS—Always turn off the fixture *before* you change lamps. Always turn off power before cleaning surfaces.

ALLOW LAMPS TO COOL BEFORE TOUCHING THEM—Do *not* touch the hot lamps; allow them to cool.

CLEAN PROPERLY—You can wipe the lamps and reflector with a clean, white lint-free cloth. Clean the diffuser and housing with a dampened cloth containing a mild soap.

DO NOT OPERATE DURING LIGHTNING STORMS—As an added protection during a lightning storm, turn off the fixture so that it will *not* experience electrical power surges or unnecessary power drops that could result in damage to lamps and electrical circuitry.

SERVICE PROPERLY—With the exception of lamp replacement, do *not* attempt to service this product yourself. If you should attempt unauthorized repairs, you may invalidate the warranty that is active on your fixture. For any other malfunctions in operation, contact X-Rite Technical Service.

GENERAL INFORMATION

Major Components

Your overhead luminaire is specifically designed to meet the needs of visual color evaluation. The housing finish is non-UV absorbing and non-yellowing. The reflector is constructed to provide even light distribution. The diffuser is made to control brightness and resist environmental effects. The daylight fluorescent lamps use X-Rite's patented seven phosphor technology providing the closest approximation to natural daylight in a fluorescent source.

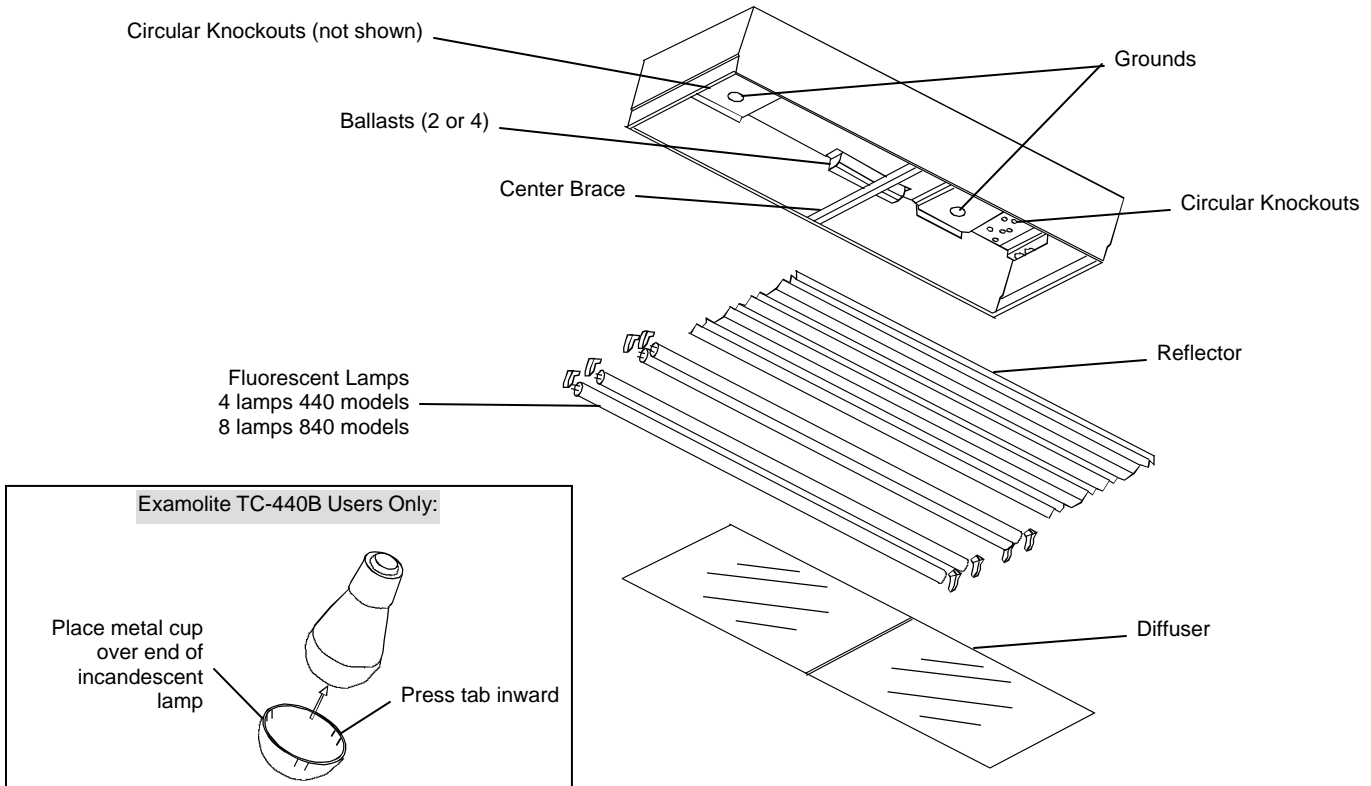

Figure 1. Luminaire Components

SET-UP

Input Power Requirements

X-Rite overhead luminaires are designed for 100VAC/ 50Hz, 117VAC/ 60Hz, 220VAC/ 50Hz-240VAC/ 50Hz, or 277VAC/ 60Hz operation. In all cases, proper input power is marked on the box and fixture label.

CAUTION

Do not operate fixture on DC input power.

Fixture	Power Consumption
Examolite TC-440B	368 watts
Examolite SD-840B	552 watts
Prooflite PLD (4-lamp fixture)	184 watts
Prooflite PLD (8-lamp fixture)	368 watts

Note: Prooflite Models PLD50/65-840, PLD50/75-840, and PLD65/75-840 operate as 4-lamp fixtures.

Recommendations For Surround

X-Rite fixtures are designed for color inspection and therefore it is important that precautions be taken to ensure the best environment for this purpose. Ambient light (natural or artificial) must be avoided. A room where the X-Rite fixture is used for general lighting should be windowless and other lighting should be eliminated. If a windowless room is unavailable, light-tight curtains or blinds should be used. If the X-Rite fixtures are used only for lighting of a localized area, then an area with little interference from other lighting should be selected or a viewing booth or an enclosing curtain should be used. The work surface and surrounding area of view should also be neutral in color. It is typically recommended that Munsell N/7 or Munsell N/8 is used.

Installation Procedure

Note: Installation should be carried out by a professional carpenter and electrician.

1. Remove the fixture from the box. Discard the plastic wrap.
2. Remove the cheesecloth bag tied to the center brace. It contains four eyebolts for a chain hung installation.
3. Using a flat head screwdriver, remove the four screws securing the reflector to the housing.
4. Remove the reflector by flexing it inward to provide clearance on both sides of the housing. Be sure the reflector clears the center brace. After the reflector is removed, you now have access to the wires, ballasts, and lamp sockets.
5. At each end of the fixture there are two knockouts designed to facilitate installation. Select and remove the appropriate knockouts for your specific electrical needs.
6. If you are mounting the fixture into a standard grid ceiling, follow the accepted mounting practices for your building code. If the fixture is to be chain hung over a work surface, follow "CHAIN HUNG MOUNTING PROCEDURE" on page 4.
7. Wire the fixture using the procedure described in "WIRING THE FIXTURE" on page 5.
8. Peel off the protective blue film on the reflector. It is only used to protect the reflector during shipment.

CAUTION

It is important to remove the protective blue film placed on the reflector for shipment purposes. If it is not removed, it may melt and cause permanent damage.

9. After the fixture has been mounted and properly wired, reposition the reflector and secure it with the screws.
10. Insert the lamps.
Note: For fixtures with two different fluorescent source types (PLD-840 dual source and Examolite SD-840B) alternate each type as you insert them.
11. Verify the unit wiring and lamp placement by selecting each source and observing the lamps illuminated.
12. *Examolite TC-440B users only:* Place a metal cup over one of the the four incandescent lamps. Press the three tabs of the metal cup inward to secure it to the lamp. See Figure 1. Repeat this step for the remaining three incandescent lamps.

CAUTION

Wear protective gloves when performing this operation to avoid finger injuries.

13. To insert the diffuser, tilt it slightly to provide clearance of the flanges and raise the lens into the housing. Position onto the housing flanges. Repeat this step for the second lens.
Note: The lens should always be inserted with its smooth side facing inside of the fixture and the prismatic (textured) side facing the outside of the fixture. Orient the lens so that the longest side is parallel to the longest side of the luminaire.

CHAIN HUNG MOUNTING PROCEDURE

Recommendations For Location Of Fixtures

There are many applications for X-Rite overhead luminaires and therefore no single installation method would be suitable for all applications. See Figure 2 and Figure 3 for the more common installation requirements. Adjustments to the dimensions may be needed to achieve the desired light level and area of view. Before proceeding to mount the fixture, refer to the weight data given below and ensure that mounting supports are adequate.

CAUTION
Mounting luminaires should only be done by a professional carpenter.

Fixture Net Weights	
Proof lite PLD (4-lamp)	57.5 lbs (25.87 kg)
Prooflite PLD (8-lamp)	68.0 lbs (30.6 kg)
Examolite TC-440B	78.0 lbs (35.1 kg)
Examolite SD-840B	90.0 lbs (40.5 kg)

On the rear of the fixture housing there are two sets of weld nuts (both standard and metric). Install the four eyebolts (supplied) into the standard weld nuts. A chain (user-supplied) can then be hooked to the eyebolts and used to suspend the fixture. Adjust the chain links to achieve the desired distance and angle.

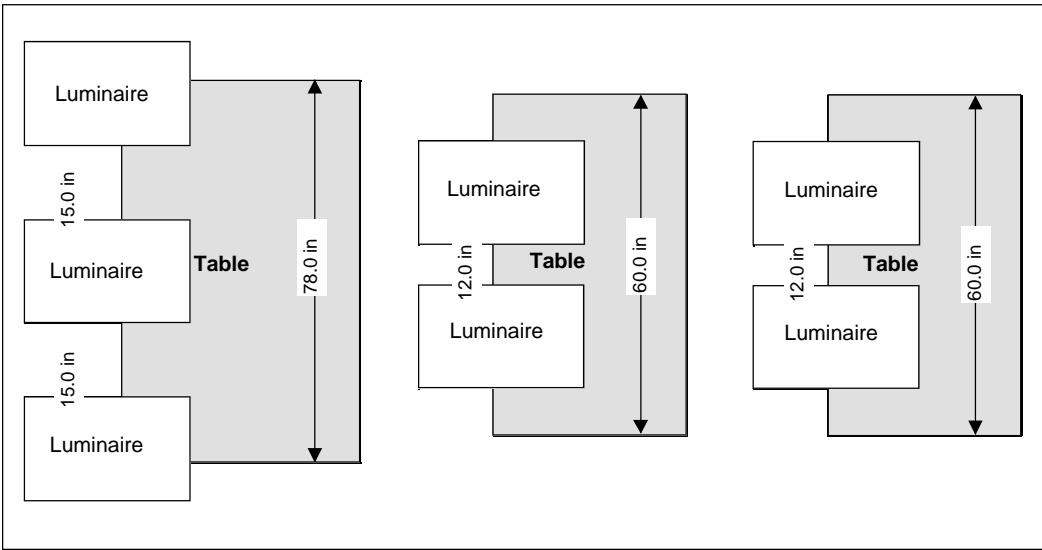

Figure 2.
Mounting Diagram- Top Views

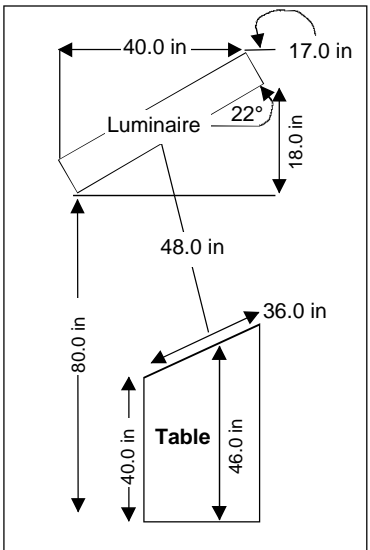

Figure 3.
Mounting Diagram- Side Views

WIRING THE FIXTURE

CAUTION

Wiring should only be performed by a professional electrician.

General

Connection of the individual ballast input leads and incandescent socket leads must be made at the time of the installation. Series ballast circuitry is used in the X-Rite Overhead Luminaires. In order to accommodate possible installation requirements, wire entry for input power is possible from either end of the fixture.

Note: All leads are arranged so that the knockouts at one end of the fixture are desirable for wire entry. If you use the other end of the fixture, note that all input wiring within 3 inches of the ballast and socket will tolerate 90° C

	Number of Lamps	Ballasts and AC Power Inputs	Ballast Control Assignments	Ballast Wiring Assignments (Note: Use Wire Nuts on All Connections)
PLD-440	4 Fluorescent	2 Ballasts 1 Input	Ballast 1: Lamps 1 and 2 Ballast 2: Lamps 3 and 4	<i>Black</i> ballast leads go to <i>black</i> AC power input. <i>White</i> ballast leads go to <i>white</i> AC power input. Ground from AC power input goes to fixture ground.
PLD-840 (Single Source)	8 Fluorescent	4 Ballasts 1 Input	Ballast 1: Lamps 1 and 3 Ballast 2: Lamps 2 and 4 Ballast 3: Lamps 5 and 7 Ballast 4: Lamps 6 and 8	<i>Black</i> ballast leads go to <i>black</i> AC power input. <i>White</i> ballast leads go to <i>white</i> AC power input. Ground from AC power input goes to fixture ground.
PLD-840 (Dual Source)	2 Sets of 4 Fluorescent	4 Ballasts 2 Inputs	Ballast 1: Lamps 1 and 3 Ballast 2: Lamps 2 and 4 Ballast 3: Lamps 5 and 7 Ballast 4: Lamps 6 and 8	<i>Black</i> leads for ballasts 1 and 3 go to <i>black</i> AC power input on first AC source. <i>White</i> leads for ballasts 1 and 3 go to <i>white</i> AC power input on first AC source. <i>Black</i> leads for ballasts 2 and 4 go to <i>black</i> AC power input on second AC source. <i>White</i> leads for ballasts 2 and 4 go to <i>white</i> AC power input on second AC source. Ground from AC power input goes to fixture ground.
TC-440B	4 Fluorescent 4 Incandescent	2 Ballasts 1 Input	Ballast 1: Lamps 1 and 2 Ballast 2: Lamps 3 and 4	<i>Black</i> ballast and incandescent leads go to <i>black</i> AC power input. <i>White</i> ballast and incandescent leads go to <i>white</i> AC power input. Ground from AC power input goes to fixture ground.
SD-840B	4 Daylight Fluorescent 4 Cool White Fluorescent 8 Incandescent	4 Ballasts 3 Inputs	Ballast 1: Lamps 1 and 3 Ballast 2: Lamps 2 and 4 Ballast 3: Lamps 5 and 7 Ballast 4: Lamps 6 and 8	<i>Black</i> leads for ballasts 1 and 3 go to <i>black</i> AC power input on first AC source. <i>White</i> leads for ballasts 1 and 3 go to <i>white</i> AC power input on first AC source. <i>Black</i> leads for ballasts 2 and 4 go to <i>black</i> AC power input on second AC source. <i>White</i> leads for ballasts 2 and 4 go to <i>white</i> AC power input on second AC source. <i>Black</i> incandescent socket leads go to <i>black</i> AC power input on third AC source. <i>White</i> incandescent socket leads go to <i>white</i> AC power input on third AC source. Ground from AC power input goes to fixture ground.

MAINTENANCE

Cleaning

An accumulation of dust, dirt, etc. will decrease the intensity of the light and also change the quality of the illumination. Therefore, the fixture must be cleaned periodically.

1. Turn the fixture off.
2. Remove the diffuser as indicated in "Removal of Diffusers".
3. Wash the glass (or acrylic) lenses with soap and water, and thoroughly rinse and dry.
4. Clean the housing with a dampened cloth containing mild soap.
5. Wipe the lamps and reflector with a clean, white, lint-free cloth.
6. Replace the diffusers.

Removal and Replacement of Components

Removal of Diffusers

1. Push one lens slightly off of the flanges of the housing. Tilt slightly to provide clearance of the flanges and lower the lens out of the housing. Repeat this step for the second lens.

Note: The lens should always be inserted with the smooth side facing inside of the fixture and the prismatic (textured) side facing the outside of the fixture. Orient the lens so that the longest side is parallel to the longest side of the luminaire.

Replacement of Lamps

Replace lamps at approximately 75 percent of their rated life expectancy to retain spectral characteristics. Replace burned out lamps immediately in order to maintain the overall performance standards of the fixture.

Lamp Replacement Schedule		
	Lamp	Number of Hours
Examolite TC-440B	F40T12/EX	5,000
	33WA19/EX	2,000
Examolite SD-840B and Prooflite PLD	F40T12/75	5,000
	F40T12/65	5,000
	F40T12/50	5,000
	F40T12/CW	12,000
	60WA/IF	2,000

Note: You do not have to remove the diffusers when replacing lamps. Carefully slide one lens on top of the other for lamp replacement.

Removal of Reflector

After removing diffusers and lamps from the housing, remove the reflector by loosening the screws and lowering the reflector out of the housing. Flex the reflector slightly inward to allow it to clear the flanges on the sides of the housing. With reflector removed, ballasts, lamp sockets, and associated wiring are accessible.

Replacement of Ballasts, Lamp Sockets, and Associated Wiring

Have a professional electrician remove the reflector to expose the wireway and replace ballasts, lamp sockets, and associated wiring.

SPECIFICATIONS

The following is a list of useful specifications.

Examolite		
Model	TC-440B	SD-840B
Light Sources	Blended Daylight, 7500K (D75)	Daylight: 7500K (D75), 6500K (D65), and 5000K (D50) Cool White Fluorescent (4150K) Illuminant "A" (2856K)
Number of Lamps	4 per source (8 Total)	4 per fluorescent source, 8 incandescent (16 Total)
Lamps	F40T12/EX fluorescent daylight lamps 33WA19/EX* incandescent lamps. *Four metal cups for the bottom of the incandescent lamps are also provided to enhance the visual content and eliminate hot spots.	X-Rite seven phosphor fluorescent daylight lamps: F40T12/75, F40T12/65, and F40T12/50 F40T12/CW fluorescent lamps 60WA/IF incandescent lamps
Dimensions	Length: 48 in (121.19 cm) Width: 23.75 in (60.3 cm) Height: 8 in (20.3 cm)	
Weight	78.0 lbs (35.4 kg)	90.0 lbs (40.8 kg)
Power Consumption	368 watts	552 watts
Electrical Requirements	100VAC/50HZ 117VAC/60HZ 220VAC/ 50HZ-240VAC/ 50Hz	

Proflite			
Model	PLD-440	PLD-840 (Single Source)	PLD-840 (Dual Source)
Light Sources	7500K (D75) 6500K (D65) 5000K (D50)	7500K (D75) 6500K (D65) 5000K (D50)	7500K (D75)/6500K (D65) 7500K (D75)/5000K (D50) 6500K (D65)/5000K (D50)
Number of Lamps	4	8	4 per source (8 Total)
Lamps	X-Rite seven phosphor fluorescent daylight lamps:	F40T12/75 F40T12/65 F40T12/50	
Dimensions	Length: 48 in (121.19 cm) Width: 23.75 in (60.3 cm) Height: 8 in (20.3 cm)		
Weight	57.5 lbs (26.1 kg)	68.0 lbs (30.8 kg)	68.0 lbs (30.8 kg)
Power Consumption	184 watts	368 watts	184 watts
Electrical Requirements	100VAC/50HZ 117VAC/60HZ 220VAC/ 50HZ-240 VAC/ 50Hz 277VAC/ 60Hz		

SPARE PARTS

Examolite TC-440B (Daylight) 48 "Lamp Kit

A-LK/ETC4448

This kit consists of eight (8), F40T12/EX, 8800K, fluorescent daylight lamps for use in the Examolite TC-440B only. Four (4) lamps are required for each overhead fixture. Lamp is sold in packages of eight (8) or as part of a specific lamp kit.

Examolite TC-440B (Illuminant A) Lamp Kit

A-LK/ETC441A

This kit consists of eight (8), 33WA19/EX, 33 watt, incandescent lamps for use in the Examolite TC-440B only. Four (4) lamps are required for each overhead fixture. Lamp is sold in packages of eight (8) or as part of a specific lamp kit.

Examolite TC-440B (Replacement) Lamp Kit

A-LK/ETC44

This kit consists of eight (8), F40T12/EX, 8800K, fluorescent daylight lamps and eight (8), 33WA19/EX, 33 watt, incandescent lamps for use in the Examolite TC-440B only. Four (4) of each lamp are required for each overhead luminaire. Lamps are sold in packages of sixteen (16) or as part of a specific lamp kit.

(7500K) Fluorescent 48 Lamp Kit

A-LK/PL7548

This kit consists of eight (8), F40T12/75, X-Rite seven (7) phosphor fluorescent daylight lamps. Four (4) or eight (8) lamps are required for each overhead fixture. Lamp is sold in packages of eight (8) or as part of a specific lamp kit.

(6500K) Fluorescent 48 Lamp Kit

A-LK/6548

This kit consists of eight (8), F40T12/65, X-Rite seven (7) phosphor fluorescent daylight lamps. Four (4) lamps or eight (8) are required for each overhead fixture. Lamp is sold in packages of eight (8) or as part of a specific lamp kit.

(5000K) Fluorescent 48 Lamp Kit

A-LK/5048

This kit consists of eight (8), F40T12/50, X-Rite seven (7) phosphor fluorescent daylight lamps. Four (4) lamps or eight (8) are required for each overhead fixture. Lamp is sold in packages of eight (8) or as part of a specific lamp kit.

Examolite SD-840B (CWF) 48 Lamp Kit

A-L/ESD5048

This kit consists of eight (8), F40T12/CW, cool white fluorescent lamps. Four (4) lamps are required for each overhead fixture. Lamp is sold in packages of eight (8) or as part of a specific lamp kit.

Examolite SD-840B (Illuminant A) Lamp Kit

A-L/ESDIA

This kit consists of eight (8) 60WA/IF, incandescent lamps for use in the Examolite SD-840B only. Eight (8) lamps are required for each overhead fixture. Lamp is sold in packages of eight (8) or as part of a specific lamp kit.

Examolite SD-840B (7500K Replacement) Lamp Kit

A-LK/ESD8475

This kit consists of four (4) F40T12/75 X-Rite seven (7) phosphor fluorescent daylight lamps, four (4) F40T12/CWF lamps, and eight (8) 60WA/IF incandescent lamps. Four (4) of each fluorescent lamps and eight (8) incandescent lamps are required for each overhead fixture. Lamps are sold in packages of sixteen (16) or as part of a specific lamp kit.

Examolite SD-840B (6500K Replacement) Lamp Kit

A-LK/ESD8465

This kit consists of four (4) F40T12/65 X-Rite seven (7) phosphor fluorescent daylight lamps, four (4) F40T12/CWF lamps, and eight (8) 60WA/IF incandescent lamps. Four (4) of each fluorescent lamps and eight (8) incandescent lamps are required for each overhead fixture. Lamps are sold in packages of sixteen (16) or as part of a specific lamp kit.

Examolite SD-840B (5000K Replacement) Lamp Kit

A-LK/ESD8450

This kit consists of four (4) F40T12/50 X-Rite seven (7) phosphor fluorescent daylight lamps, four (4) F40T12/CWF lamps, and eight (8) 60WA/IF incandescent lamps. Four (4) of each fluorescent lamps and eight (8) incandescent lamps are required for each overhead fixture. Lamps are sold in packages of sixteen (16) or as part of a specific lamp kit.

Prooflite PLD (5000K/6500K) 48 Lamp Kit

A-LK/PL506548

This kit consists of four (4) F40T12/50 and four (4) F40T12/65 X-Rite seven (7) phosphor fluorescent daylight lamps. Four (4) of each lamp are required for each PLD50/65-840 overhead fixture. Lamps are sold in packages of eight (8) lamps or as part of a specific lamp kit.

Prooflite PLD (5000K/7500K) 48 Lamp Kit

A-LK/PL507548

This kit consists of four (4) F40T12/50 and four (4) F40T12/75 X-Rite seven (7) phosphor fluorescent daylight lamps. Four (4) of each lamp are required for each PLD50/75-840 overhead fixture. Lamps are sold in packages of eight (8) lamps or as part of a specific lamp kit.

Overhead Fixture (Glass) Diffuser

A-DK/G

Prismatic "water white" glass diffuser. Two (2) diffusers required for each overhead fixture. Replacements are sold individually.

Overhead Fixture (Acrylic) Diffuser

A-DK/A

Matte white, UV stabilized, acrylic diffuser. For use in diamond grading, in applications that require a more diffuse source (low brightness), or in applications that will not allow glass to be used. Two (2) diffusers required for each overhead fixture. Replacements are sold separately.

WARRANTY INFORMATION

X-Rite, Incorporated ("X-Rite") warrants each instrument manufactured to be free of defects in material and workmanship for a period of 12 months. This warranty shall be fulfilled by the repair or replacement, at the option of X-Rite, of any part or parts, free of charge including labor, F.O.B. its factory or authorized service center.

This warranty shall be voided by any repair, alteration, or modification, by persons other than employees of X-Rite, or those expressly authorized by X-Rite to perform repairs, and by any abuse, misuse, or neglect of the product, or by use not in accordance with X-Rite's published instructions.

X-Rite reserves the right to make changes in design and /or improvements to its products without any obligation to include these changes in any products previously manufactured. Correction of defects by repair or replacement shall constitute fulfillment of all warranty obligations on the part of X-Rite.

THIS WARRANTY IS EXPLICITLY IN LIEU OF ANY OTHER EXPRESSED OR IMPLIED WARRANTIES, INCLUDING ANY IMPLIED WARRANTY OF MERCHANTABILITY OR FITNESS FOR ANY PARTICULAR PURPOSE. THIS WARRANTY OBLIGATION IS LIMITED TO REPAIR OR REPLACEMENT OF THE UNIT RETURNED TO X-RITE OR AN AUTHORIZED SERVICE CENTER FOR THAT PURPOSE.

This agreement shall be interpreted in accordance with the laws of the State of Michigan and jurisdiction and venue shall lie with the courts of Michigan as selected by X-Rite, Incorporated.

Changes are made periodically to the information contained this manual. These changes will be incorporated into new editions of this publication. X-Rite makes no warranty of any kind with regard to the material contained in this manual, including, implied warranties or fitness for a particular purpose. X-Rite shall not be liable for errors contained herein or for incidental or consequential damages in connection with the performance or use of this material. This manual, as well as any revisions are the copyright of X-Rite. Any reproduction of the publication in whole or in part without the express permission of X-Rite is a breach of this copyright.

Examolite® and Proofflite® are registered trademarks of X-Rite, Incorporated. All other logos, brand names, and product names mentioned are the properties of their respective holders.



Corporate Headquarters - USA

4300 44th Street SE
Grand Rapids, Michigan 49512
Phone 1 800 248 9748 or 1 616 803 2100
Fax 1 800 292 4437 or 1 616 803 2705

Corporate Headquarters - Europe

Althardstrasse 70
8105 Regensdorf
Switzerland
Phone (+41) 44 842 24 00
Fax (+41) 44 842 22 22

Corporate Headquarters - Asia

Room 808-810
Kornhill Metro Tower, 1 Kornhill Road
Quarry Bay, Hong Kong
Phone (+852) 2 568 6283
Fax (+852) 2 885 8610

Please visit www.xrite.com for a local office near you.